

[54] TOY ROBOT-AIRCRAFT WATCH

[75] Inventor: Takayoshi Doi, Ichikawa, Japan

[73] Assignee: Takara Co., Ltd., Tokyo, Japan

[**] Term: 14 Years

[21] Appl. No.: 696,641

[22] Filed: Jan. 30, 1985

[30] Foreign Application Priority Data

Dec. 27, 1984 [JP] Japan 59-53237

[52] U.S. Cl. D10/33; D21/150; 446/487; D10/35

[58] Field of Search D10/33, 35, 38, 32, D10/31; D21/150, 128, 144, 166; 368/10; 446/71-73, 76-77, 487

[56] References Cited

U.S. PATENT DOCUMENTS

- D. 278,643 4/1985 Ogawa D21/150 X
- D. 279,804 7/1985 Ohno D21/150 X
- D. 281,090 10/1985 Murakami D21/150
- D. 285,417 9/1986 Nakane D10/33
- D. 286,511 11/1986 Wada D10/35
- D. 287,037 12/1986 Matsushiro D21/150
- D. 287,378 12/1986 Ohno D21/150 X
- D. 287,698 1/1987 Ogawa D10/35
- D. 288,343 2/1987 Ogawa D21/150 X
- 4,456,384 6/1984 Murakami 368/10
- 4,482,256 11/1984 Matsuda 368/10
- 4,571,199 2/1986 Murakami 446/73

OTHER PUBLICATIONS

Hong Kong Enterprise-1/85-p. 130, "Gobot" Robot Watches.

Hong Kong Enterprise-1/85-p. 219-Robot Watches.

Primary Examiner—Nelson C. Holtje
Attorney, Agent, or Firm—Price, Gess & Ubell

[57] CLAIM

The ornamental design for a toy robot-aircraft watch, substantially as shown and described.

DESCRIPTION

FIG. 1 is a right front perspective view of a toy robot-aircraft watch showing my new design;
 FIG. 2 is a front elevational view thereof;
 FIG. 3 is a right side elevational view thereof;
 FIG. 4 is a left side elevational view thereof;
 FIG. 5 is a rear elevational view thereof;
 FIG. 6 is a top plan view thereof;
 FIG. 7 is a bottom plan view thereof;
 FIG. 8 is a left front perspective view of the robot-aircraft watch portion with the holder-strap omitted for clarity of illustration;
 FIG. 9 is a front elevational view of FIG. 8;
 FIG. 10 is a right side elevational view of FIG. 8;
 FIG. 11 is a left side elevational view of FIG. 8;
 FIG. 12 is a rear elevational view of FIG. 8;
 FIG. 13 is a top plan view of FIG. 8;
 FIG. 14 is a bottom plan view of FIG. 8;
 FIG. 15 is a right front perspective view of FIG. 8, with portions thereof in alternate positions and reconfigured as an aircraft;
 FIG. 16 is a bottom plan view of FIG. 15;
 FIG. 17 is a right side elevational view of FIG. 15;
 FIG. 18 is a left side elevational view FIG. 15;
 FIG. 19 is a top plan view of FIG. 15;
 FIG. 20 is a front elevational view of FIG. 15;
 FIG. 21 is a rear elevational view of FIG. 15;
 FIG. 22 is a right front perspective view of FIG. 8, with portions thereof in alternate positions and reconfigured as a robot;
 FIG. 23 is a front elevational view of FIG. 22;
 FIG. 24 is a right side elevational view of FIG. 22;
 FIG. 25 is a left side elevational view of FIG. 22;
 FIG. 26 is a rear elevational view of FIG. 22;
 FIG. 27 is a top plan view of FIG. 22;
 FIG. 28 is a bottom plan view of FIG. 22;
 FIG. 29 is a front elevational view of the holder/strap portion with the robot-aircraft watch portion omitted for clarity of illustration;
 FIG. 30 is a rear elevational view of FIG. 29.

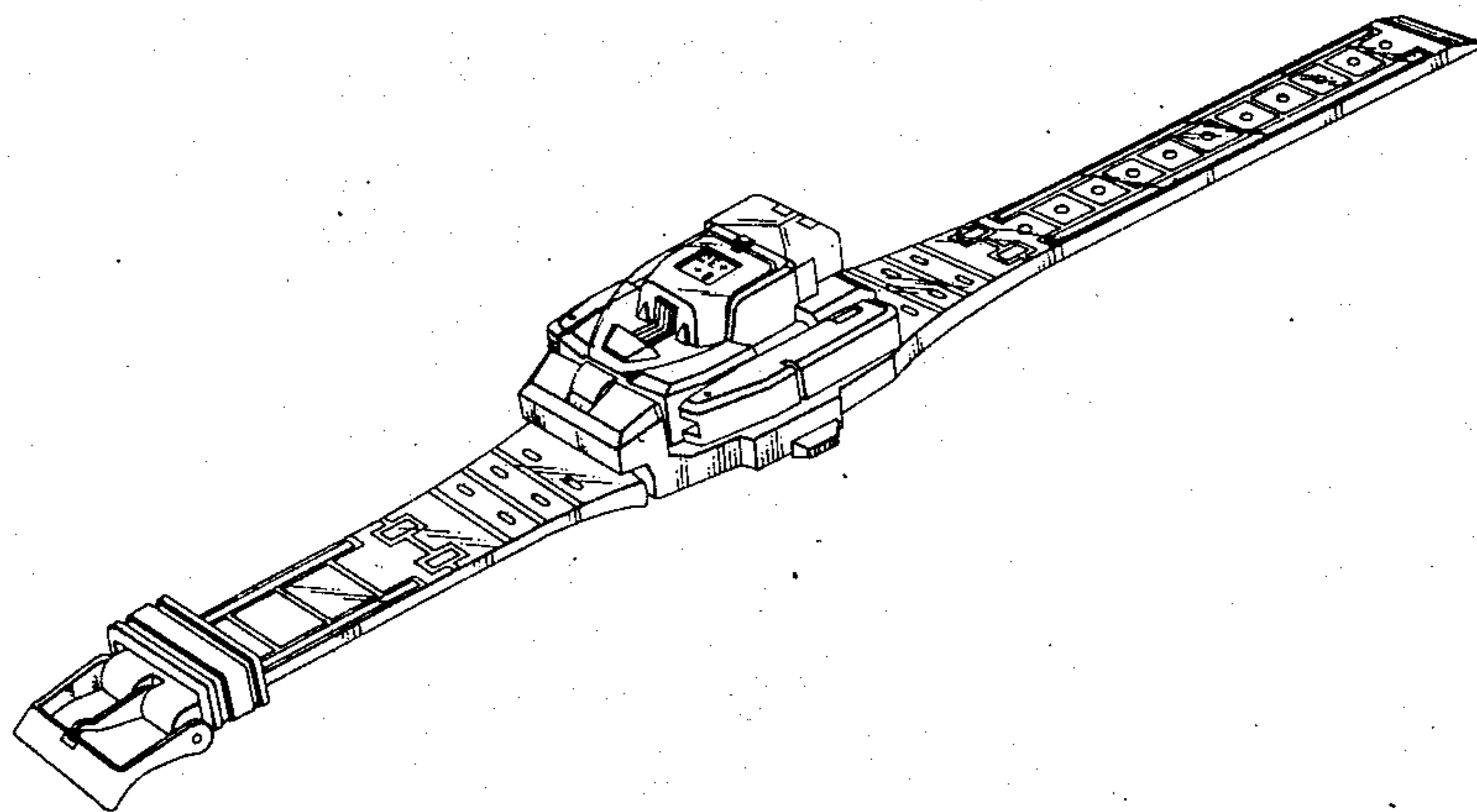

FIG. 1

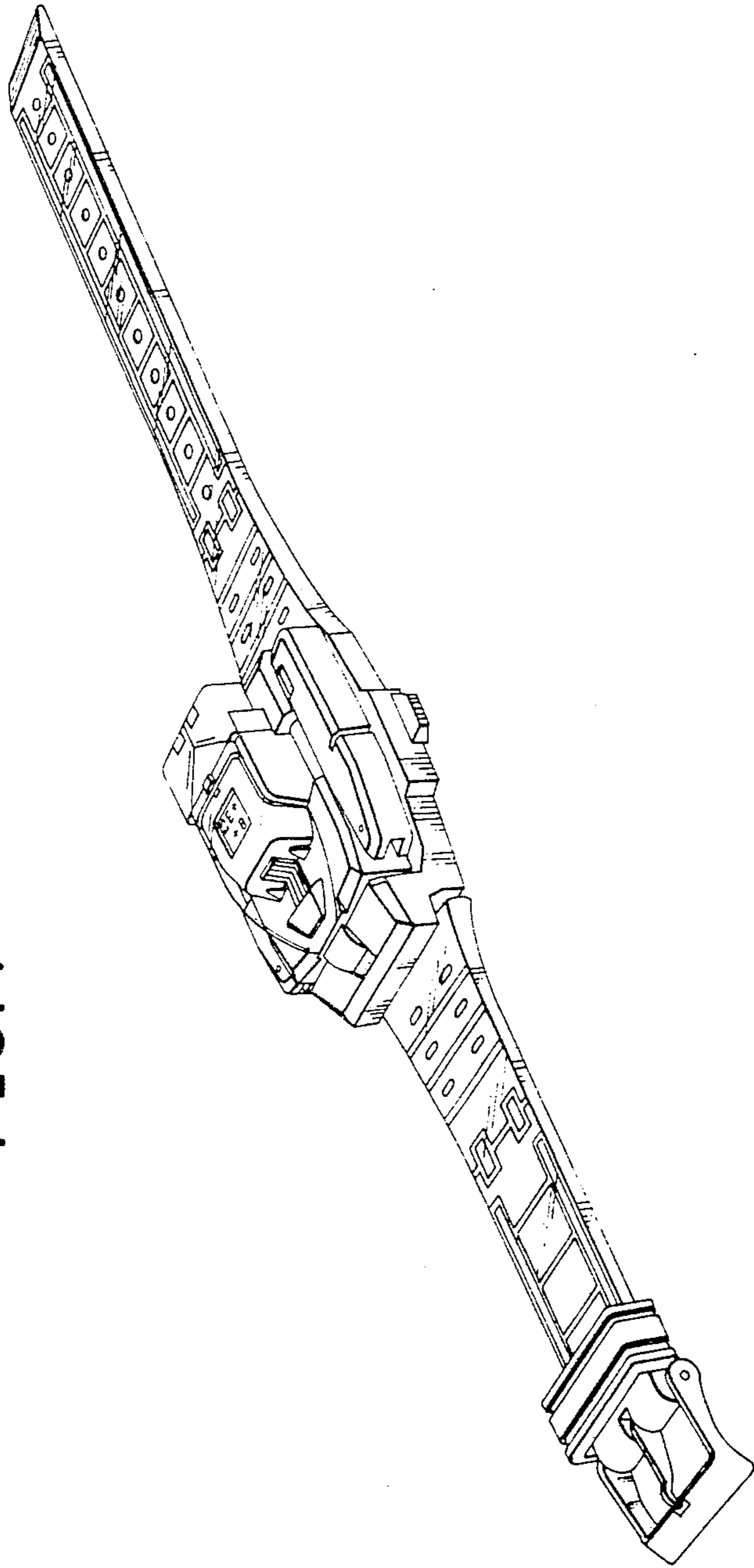

FIG. 2

FIG. 3

FIG. 4

FIG. 5

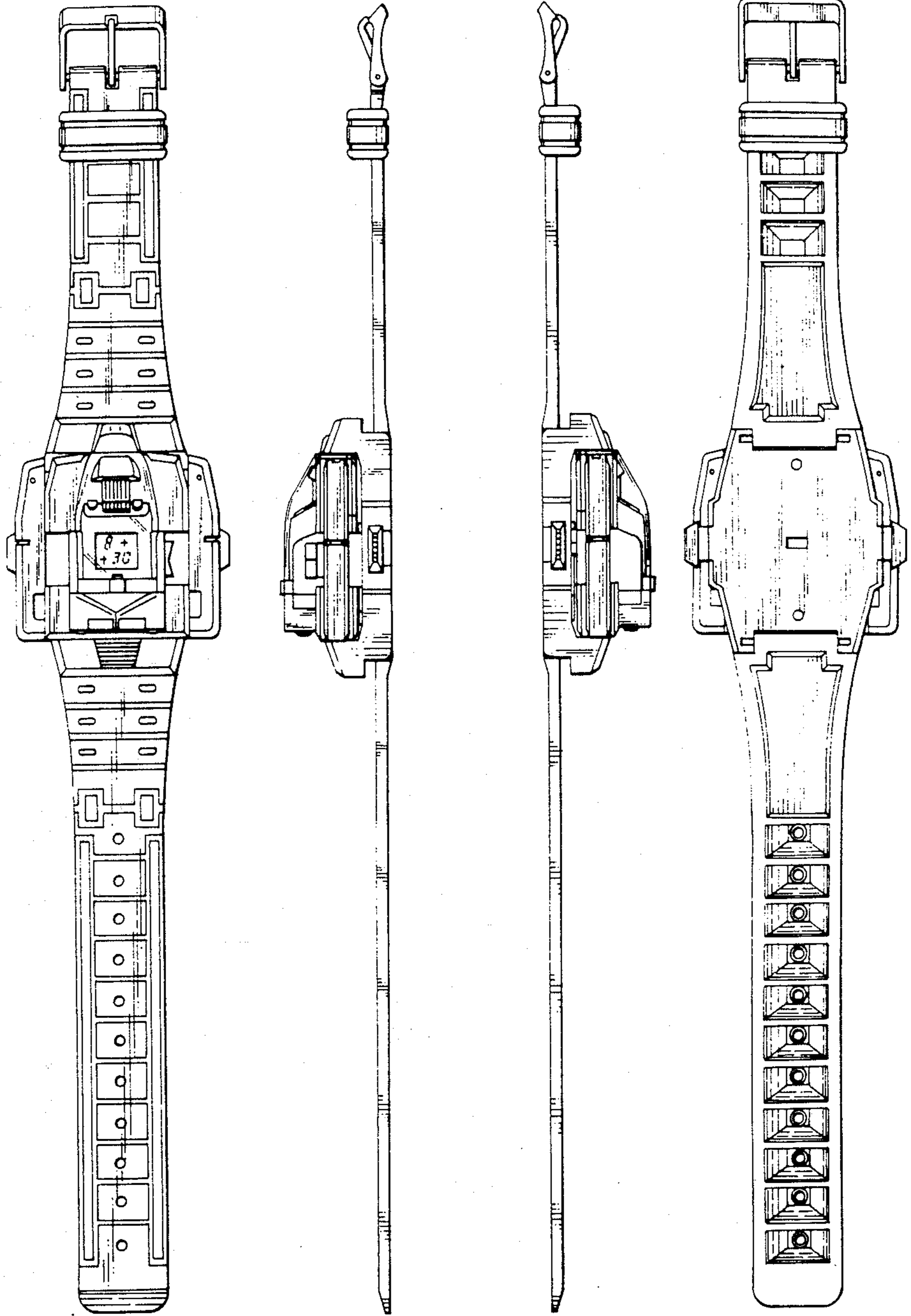
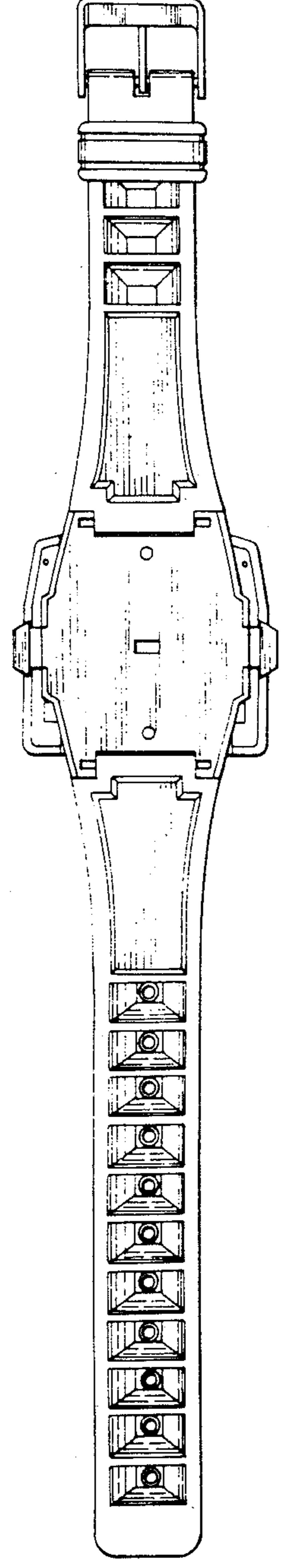
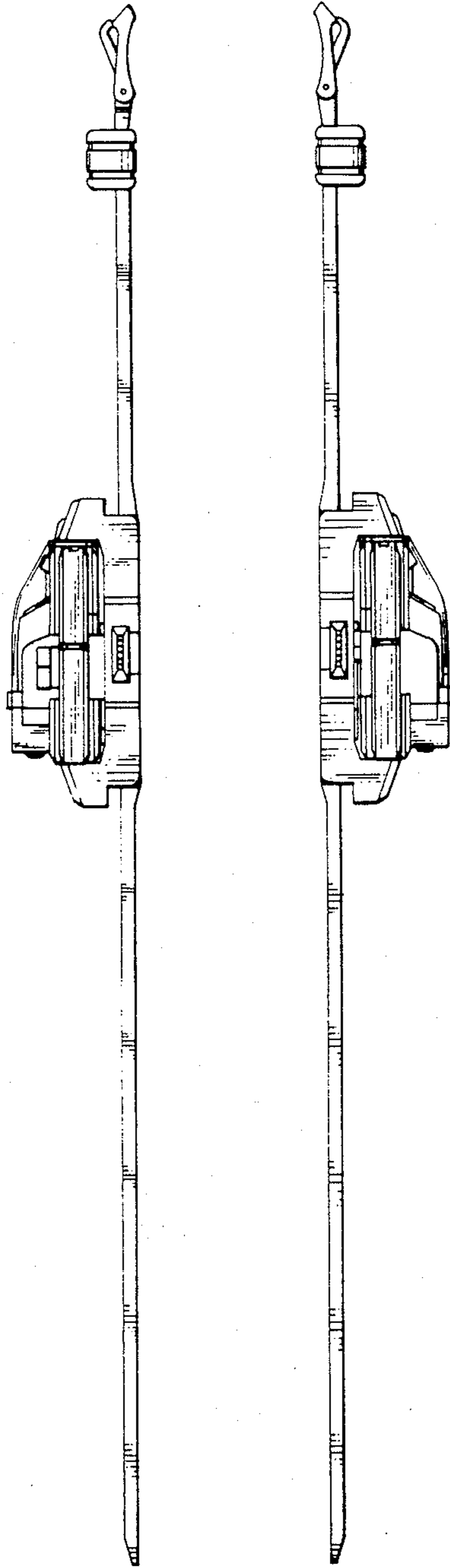
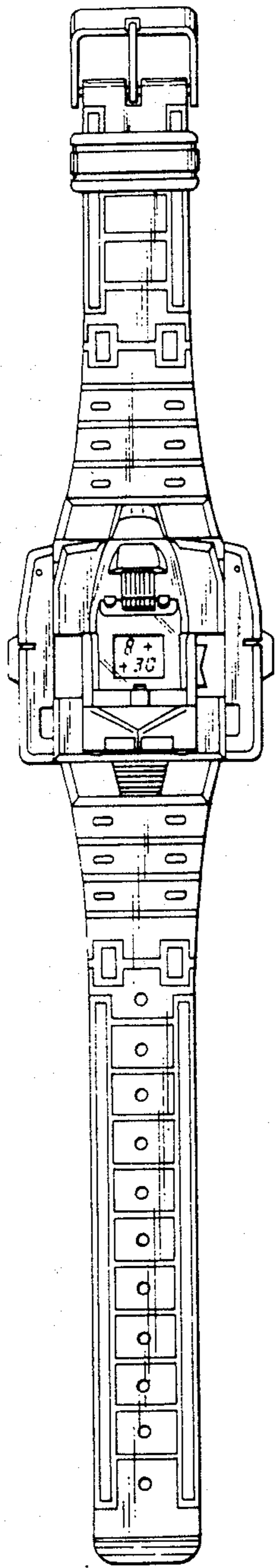

FIG. 6

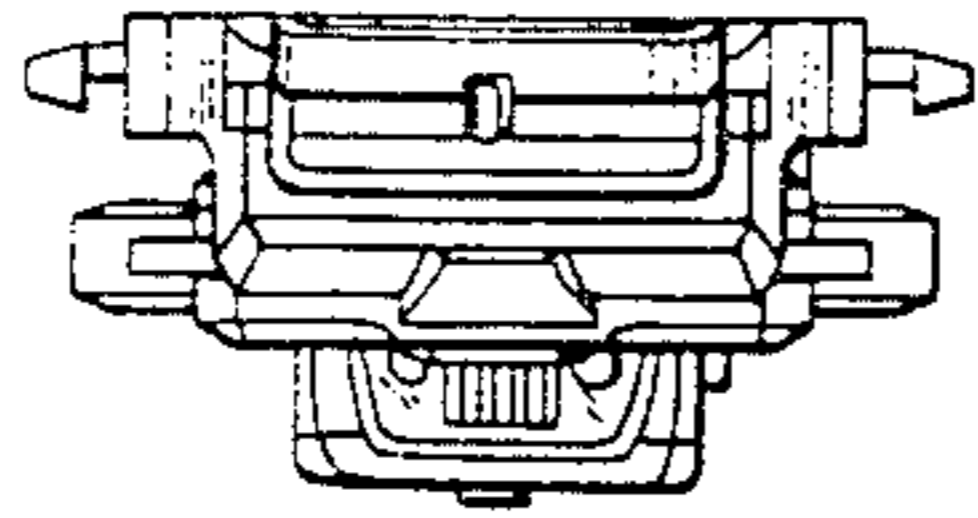

FIG. 7

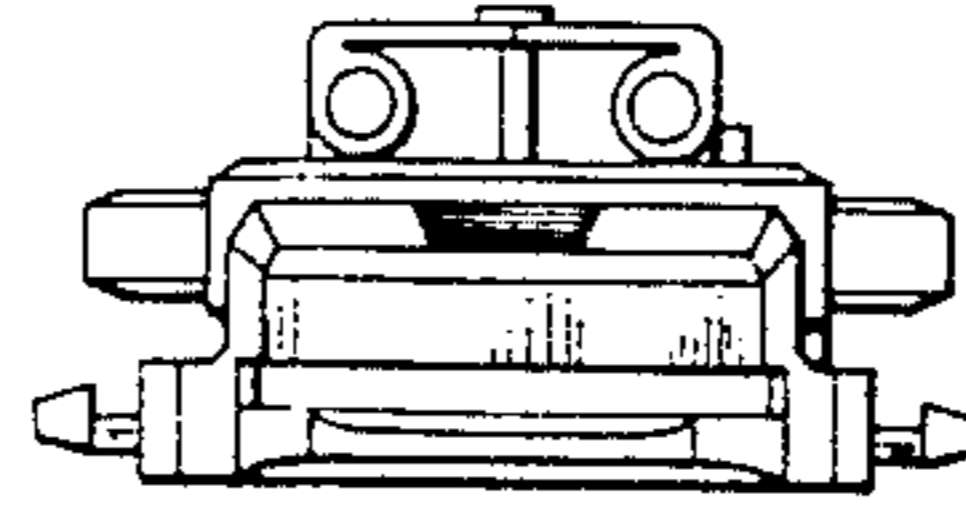

FIG. 8

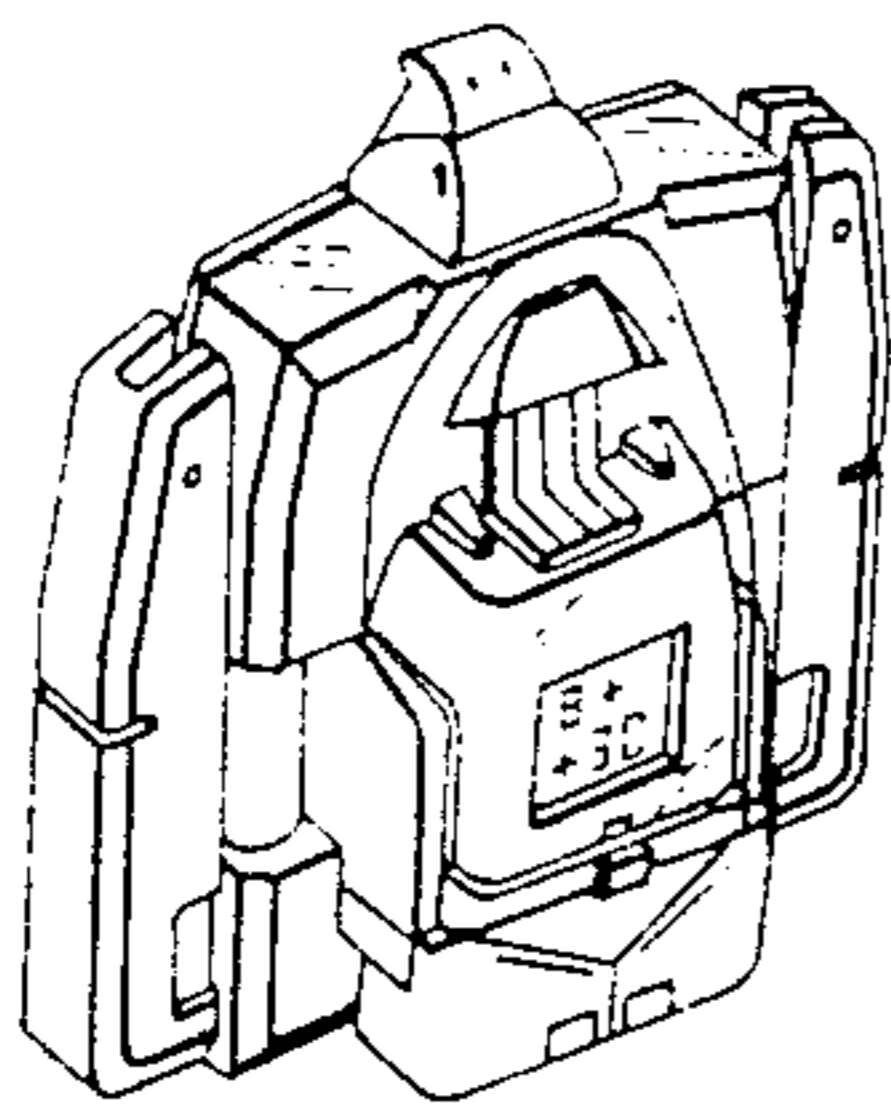

FIG. 9

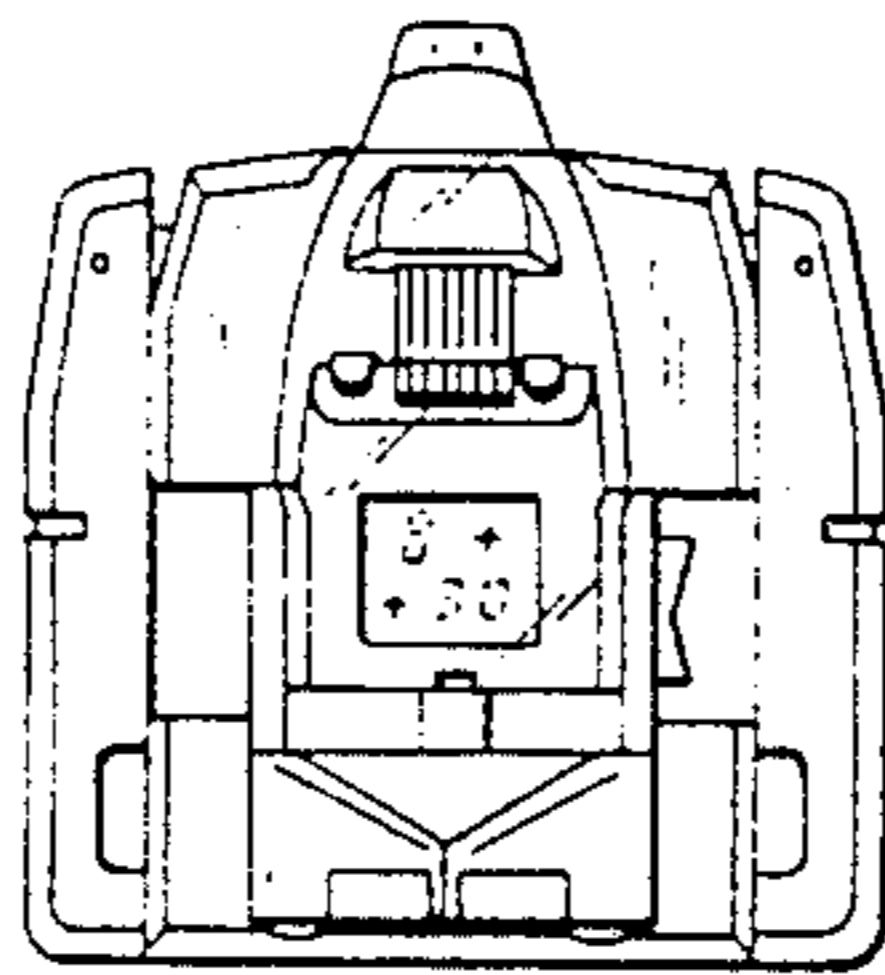

FIG. 10

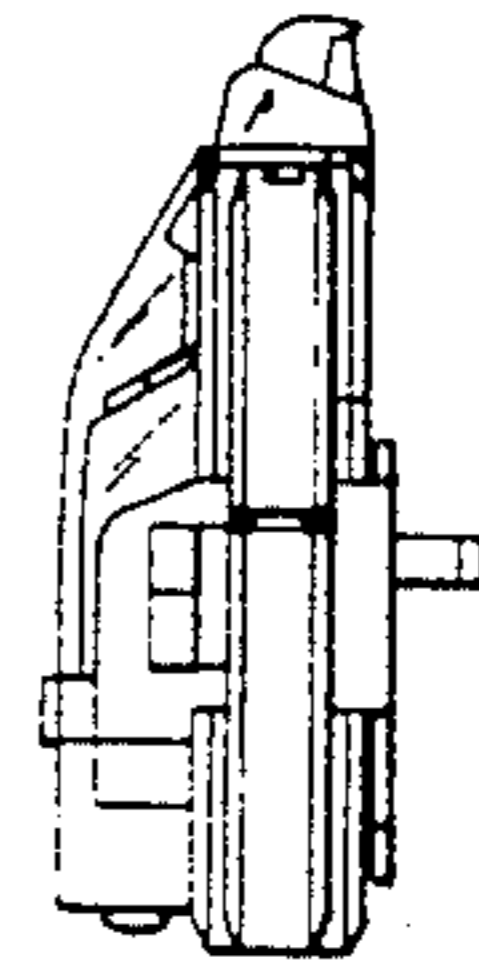

FIG. 11

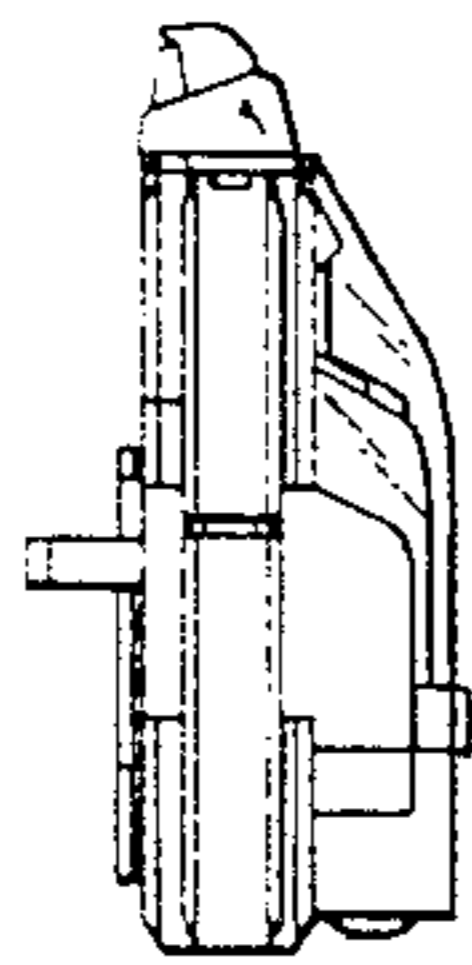

FIG. 12

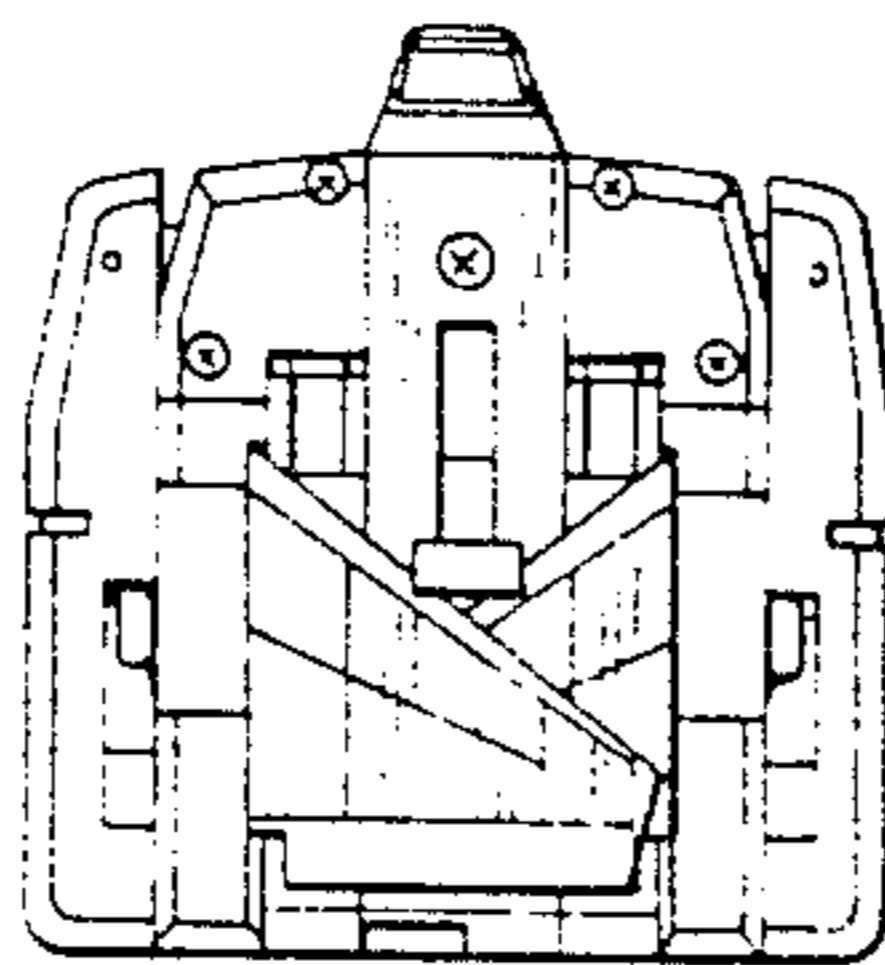

FIG. 13

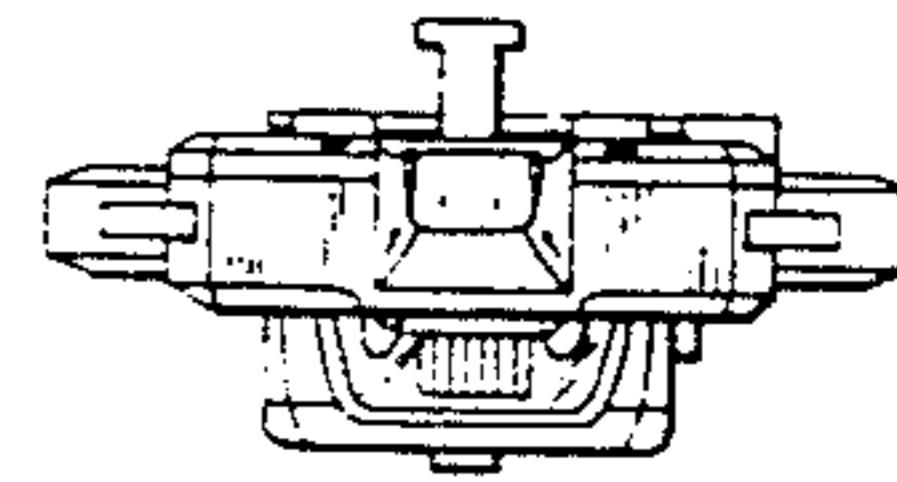

FIG. 14

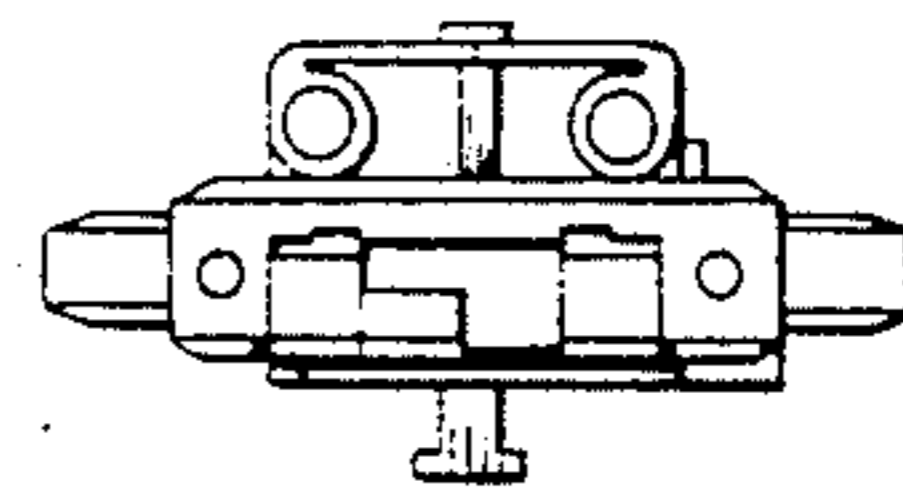

FIG. 15

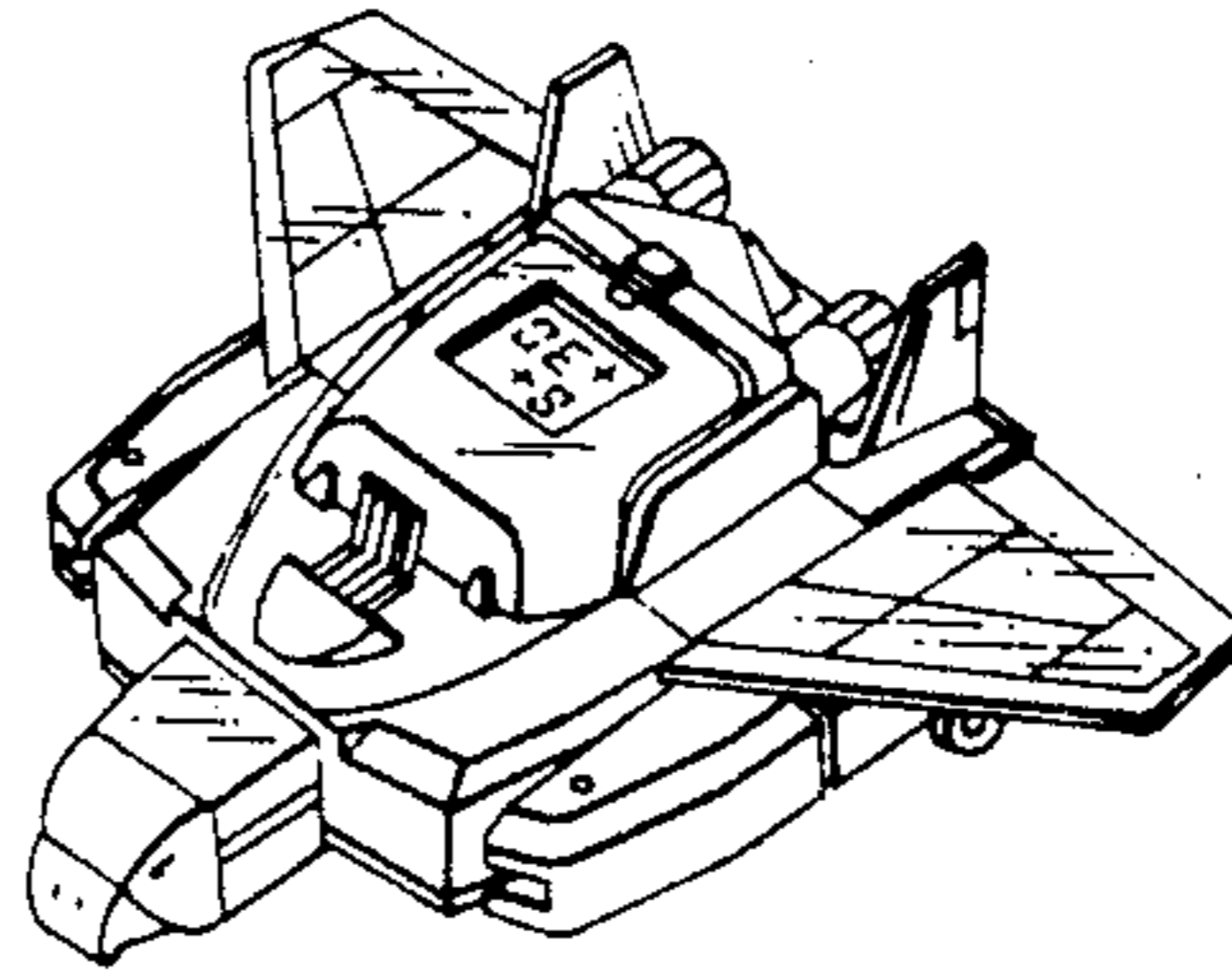

FIG. 16

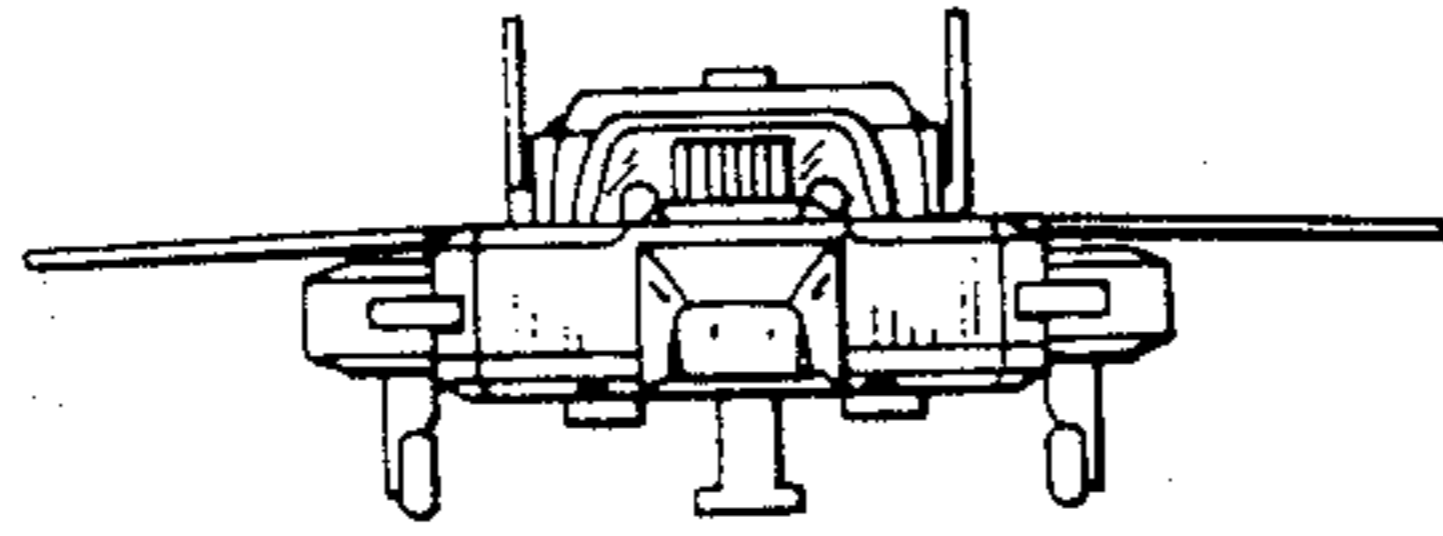

FIG. 17

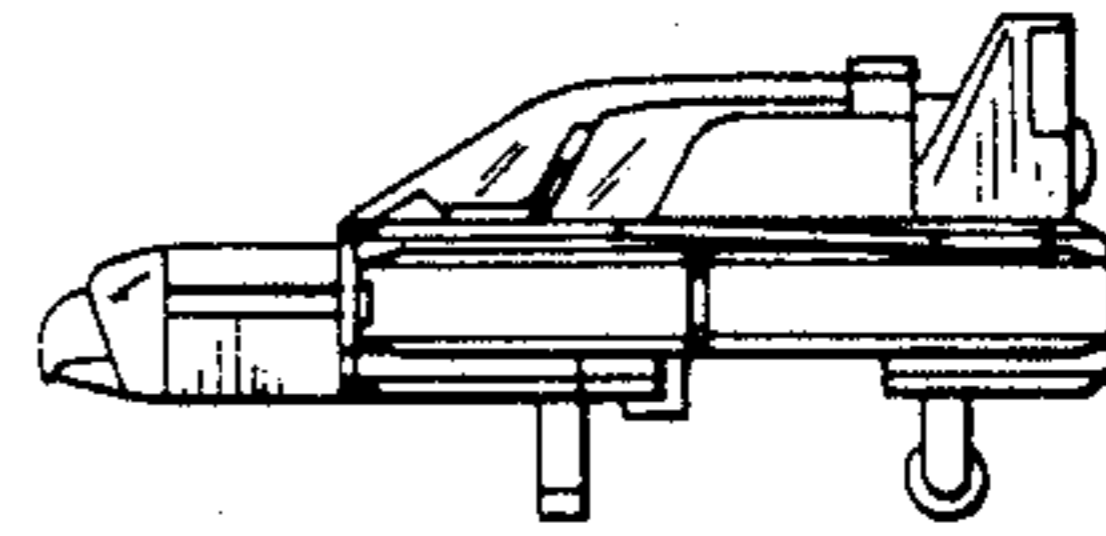

FIG. 18

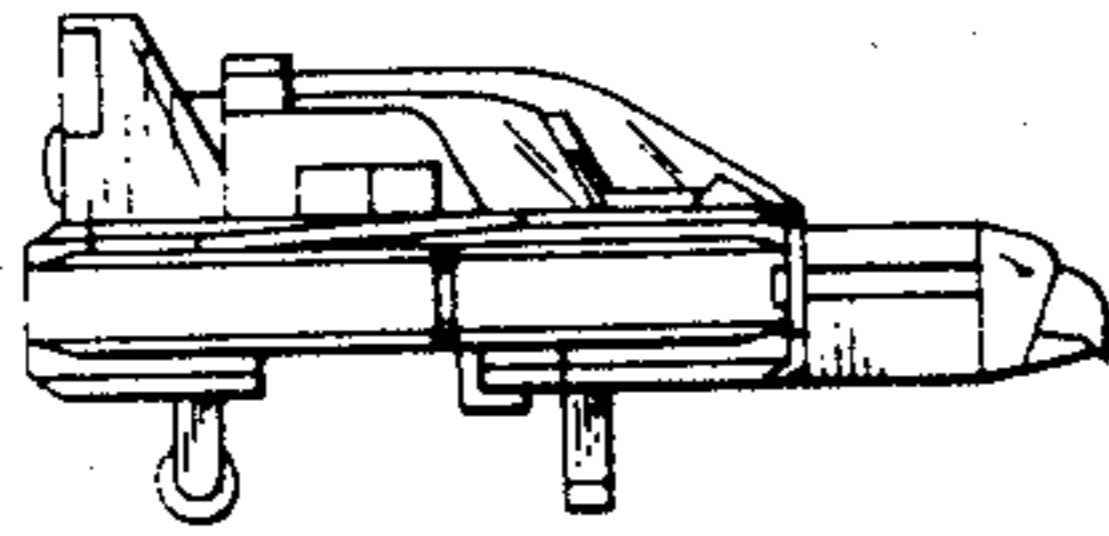

FIG. 19

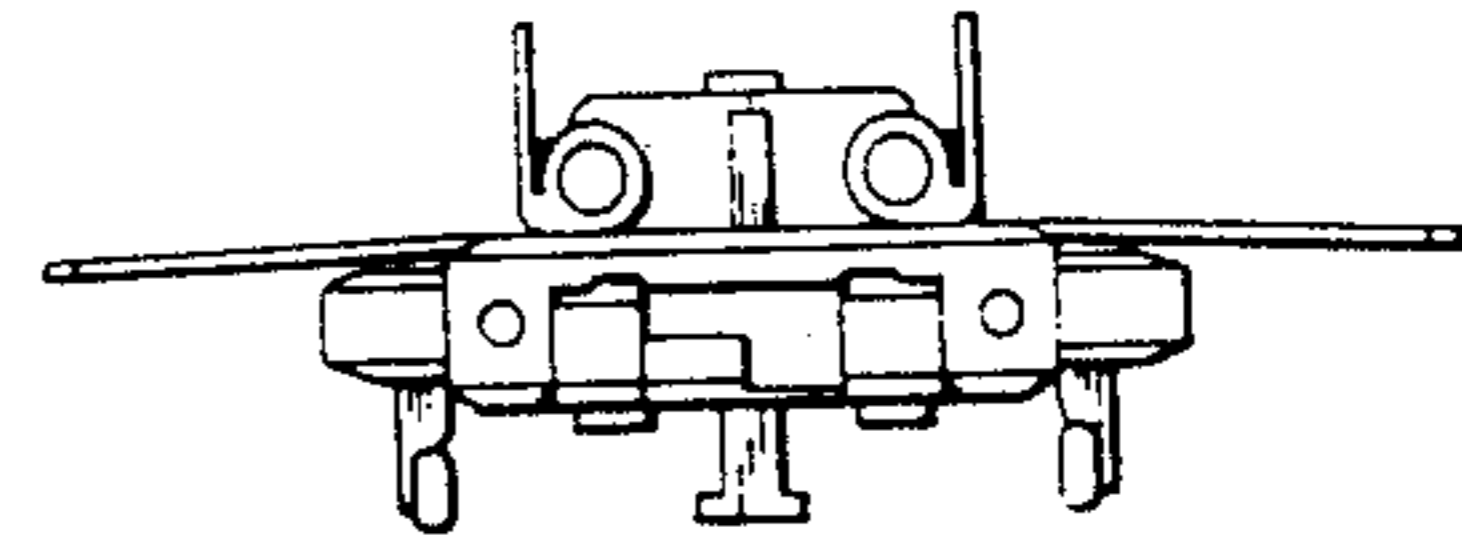

FIG. 20

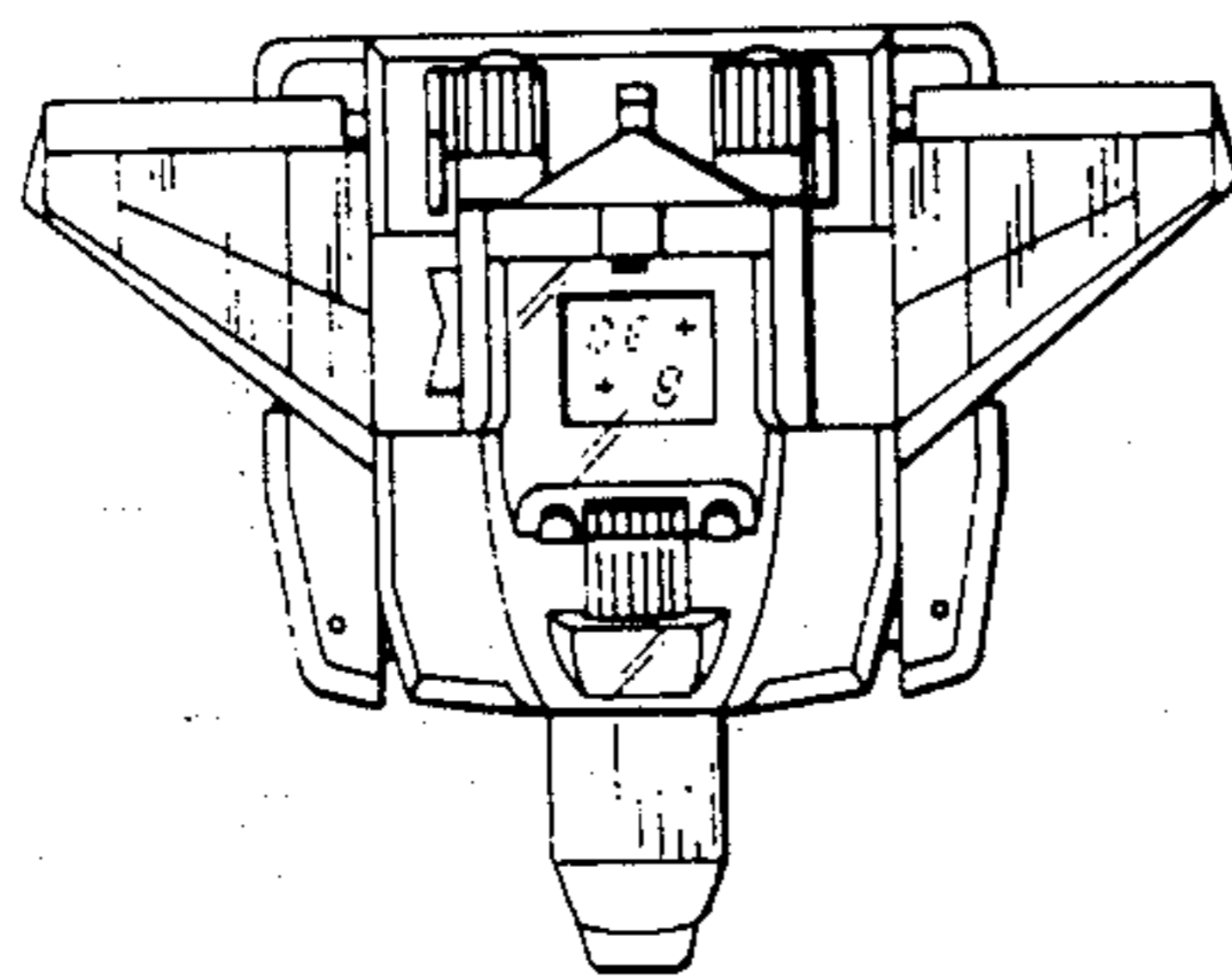

FIG. 21

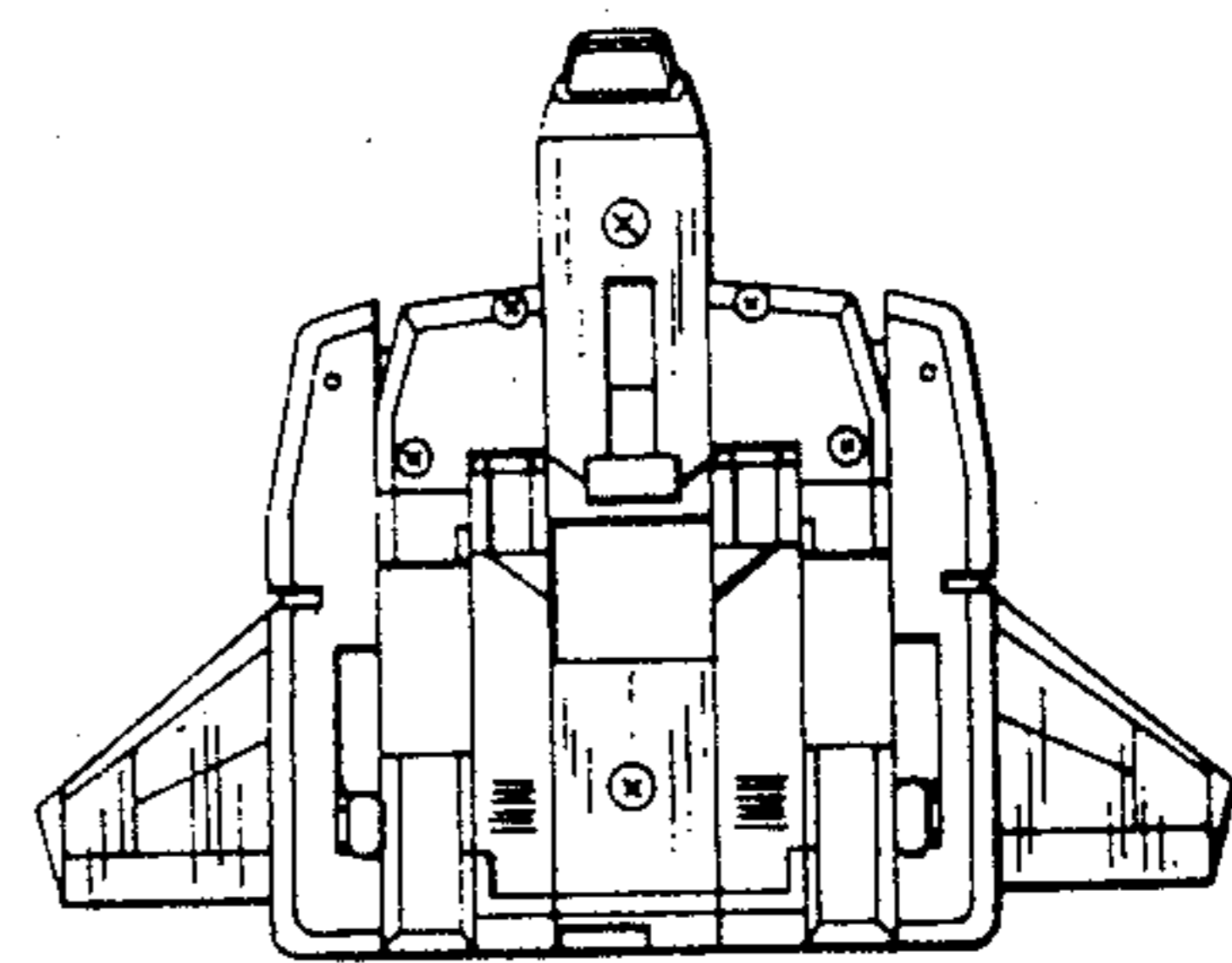

FIG.22

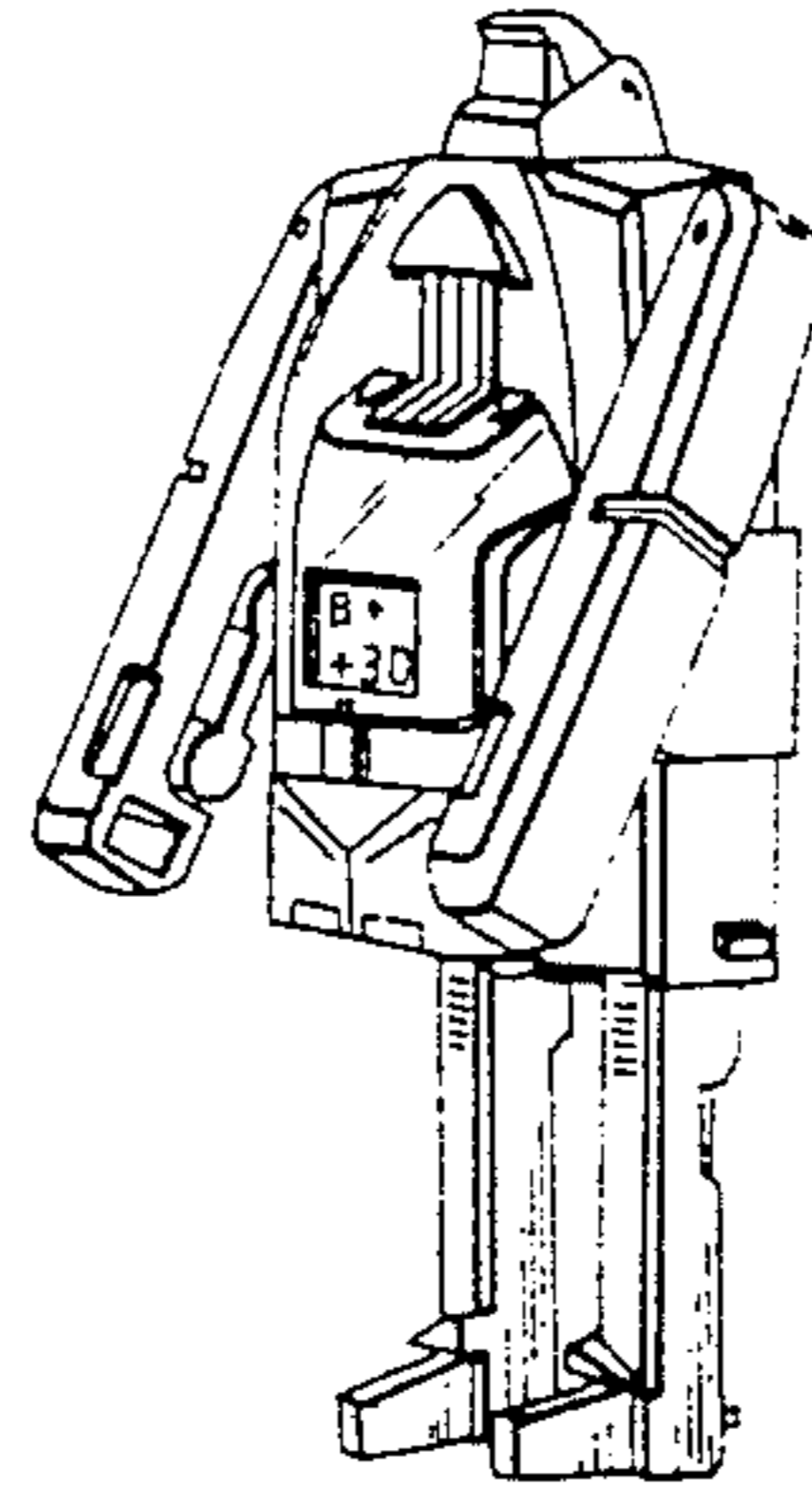

FIG.23

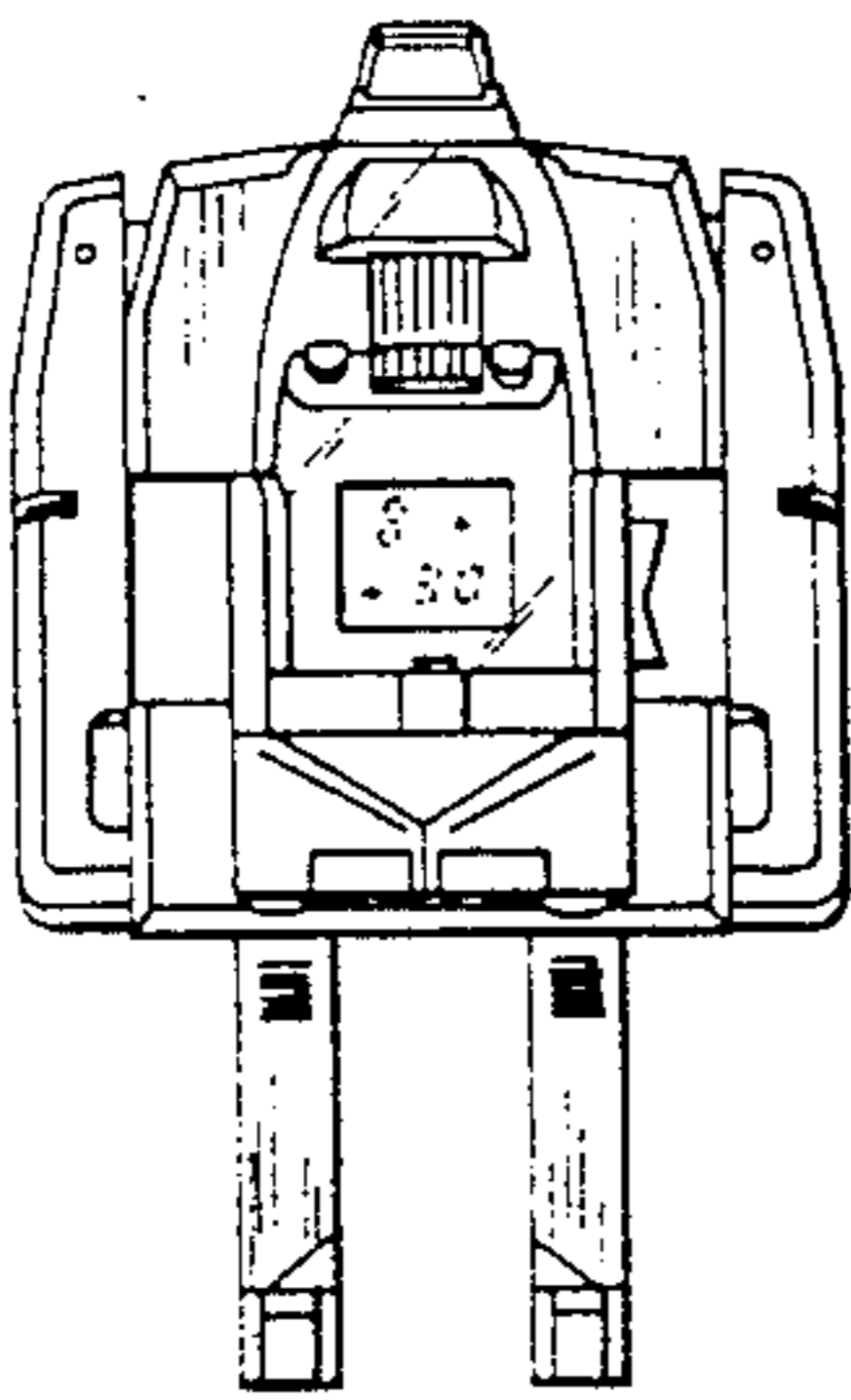

FIG.24

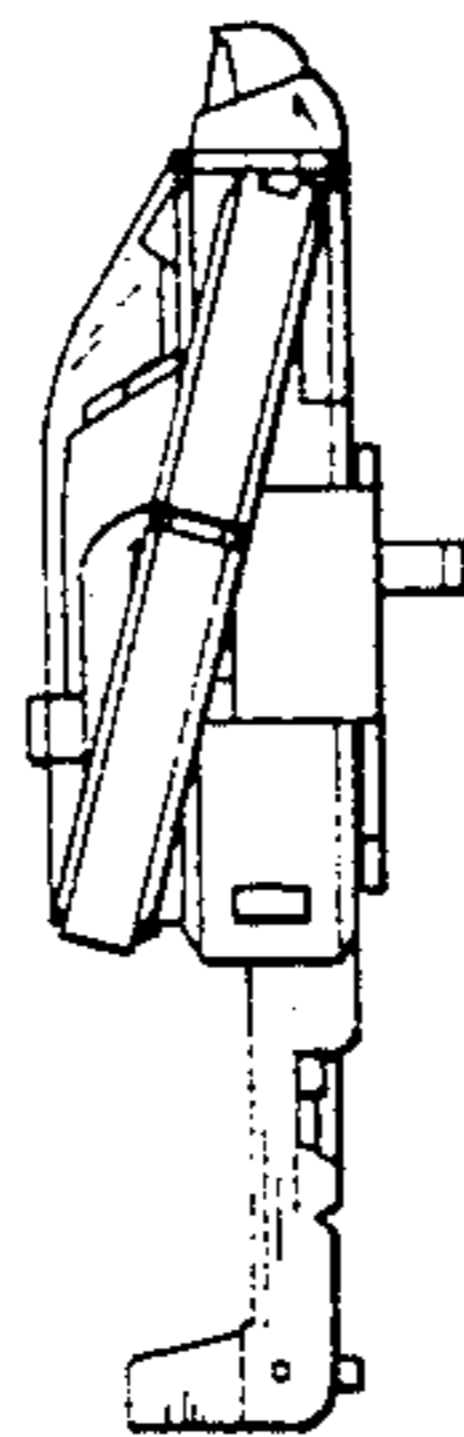

FIG.25

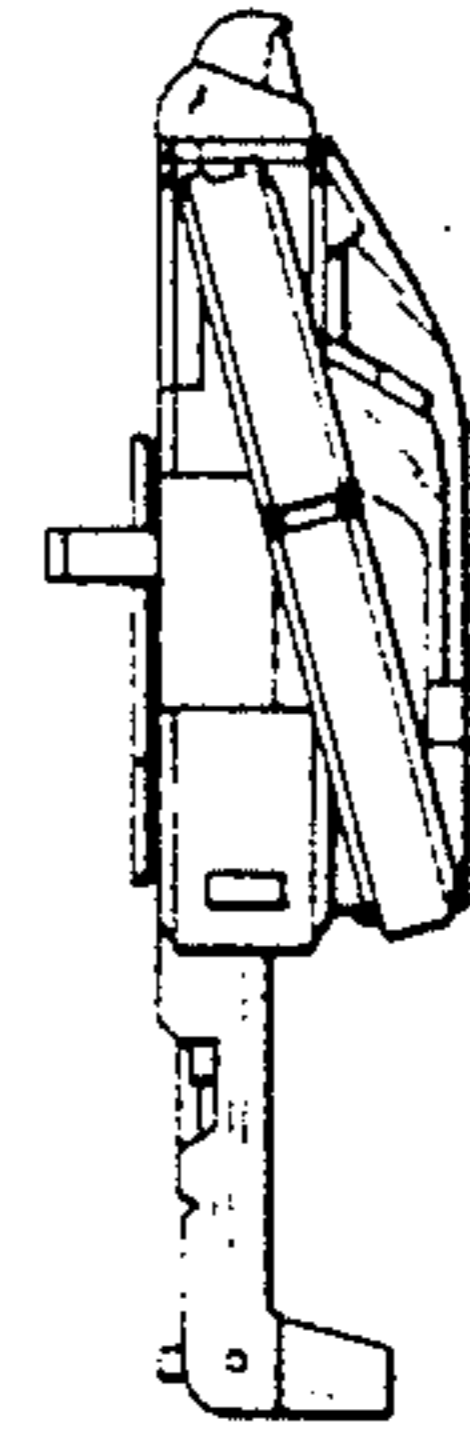

FIG.26

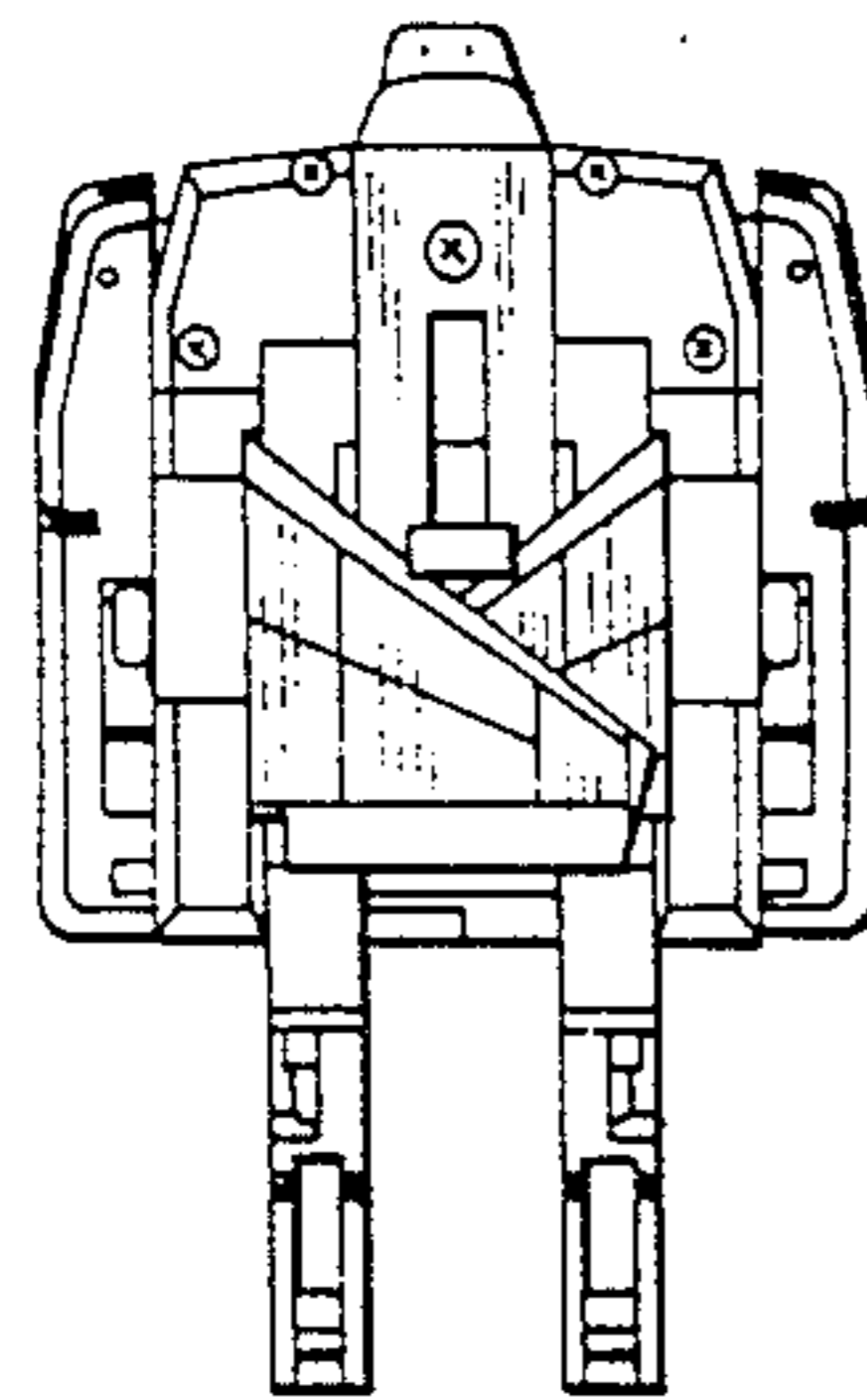

FIG.27

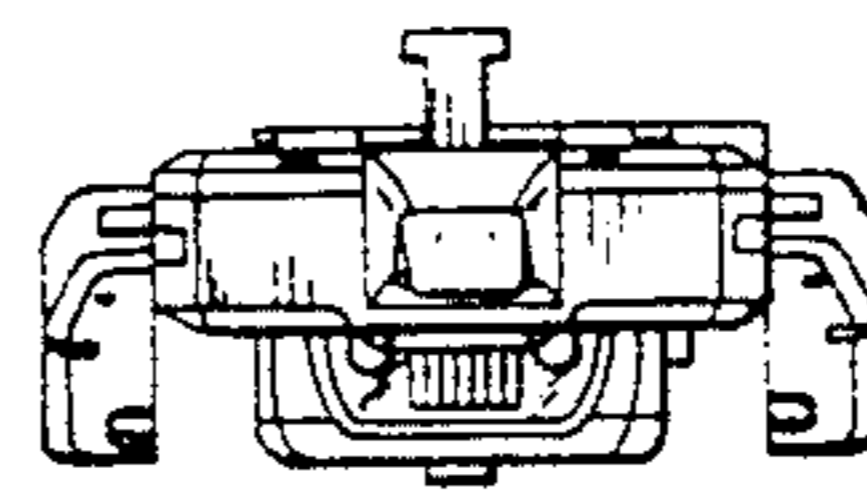

FIG.28

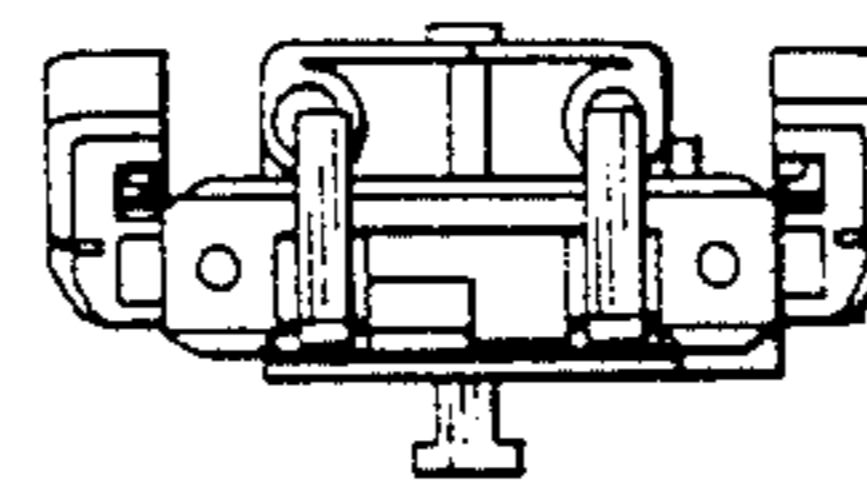

FIG.29

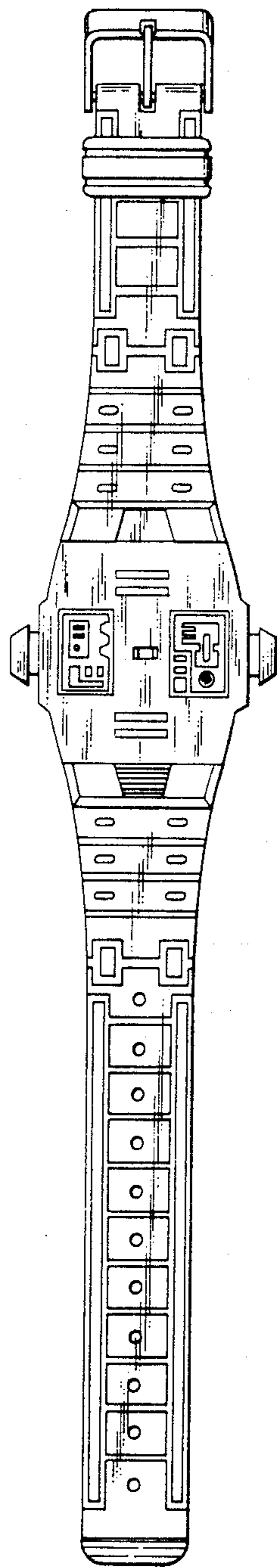

FIG.30

