

[54] REAR COMBINATION LAMP FOR AN AUTOMOBILE

D. 273,234 3/1984 Luthé .
D. 285,122 8/1986 Fujita D26/35

[75] Inventor: Mitsunori Miyazaki, Toyota, Japan

FOREIGN PATENT DOCUMENTS

[73] Assignee: Toyota Jidosha Kabushiki Kaisha, Toyota, Japan

623537 4/1984 Japan .

[**] Term: 14 Years

Primary Examiner—Susan J. Lucas
Attorney, Agent, or Firm—Cushman, Darby & Cushman

[21] Appl. No.: 760,972

[57] CLAIM

[22] Filed: Jul. 31, 1985

The ornamental design for a rear combination lamp for an automobile, substantially as shown.

[52] U.S. Cl. D26/28

DESCRIPTION

[58] Field of Search D26/28-36,
D26/120, 122, 123, 124; 362/61, 80-83,
326-340

FIG. 1 is a perspective view of a rear combination lamp for an automobile showing my new design;
FIG. 2 is a front elevational view thereof;
FIG. 3 is a rear elevational view thereof;
FIG. 4 is a top plan view thereof;
FIG. 5 is a bottom plan view thereof;
FIG. 6 is a left side elevational view thereof;
FIG. 7 is a right side elevational view thereof;
FIG. 8 is a cross-sectional view taken along line VII-VIII in FIG. 2.

[56] References Cited

U.S. PATENT DOCUMENTS

- D. 221,990 9/1971 Tixier .
- D. 222,557 11/1971 Tixier .
- D. 271,142 10/1983 Hirasawa D26/120
- D. 271,143 10/1983 Hirakawa D26/120

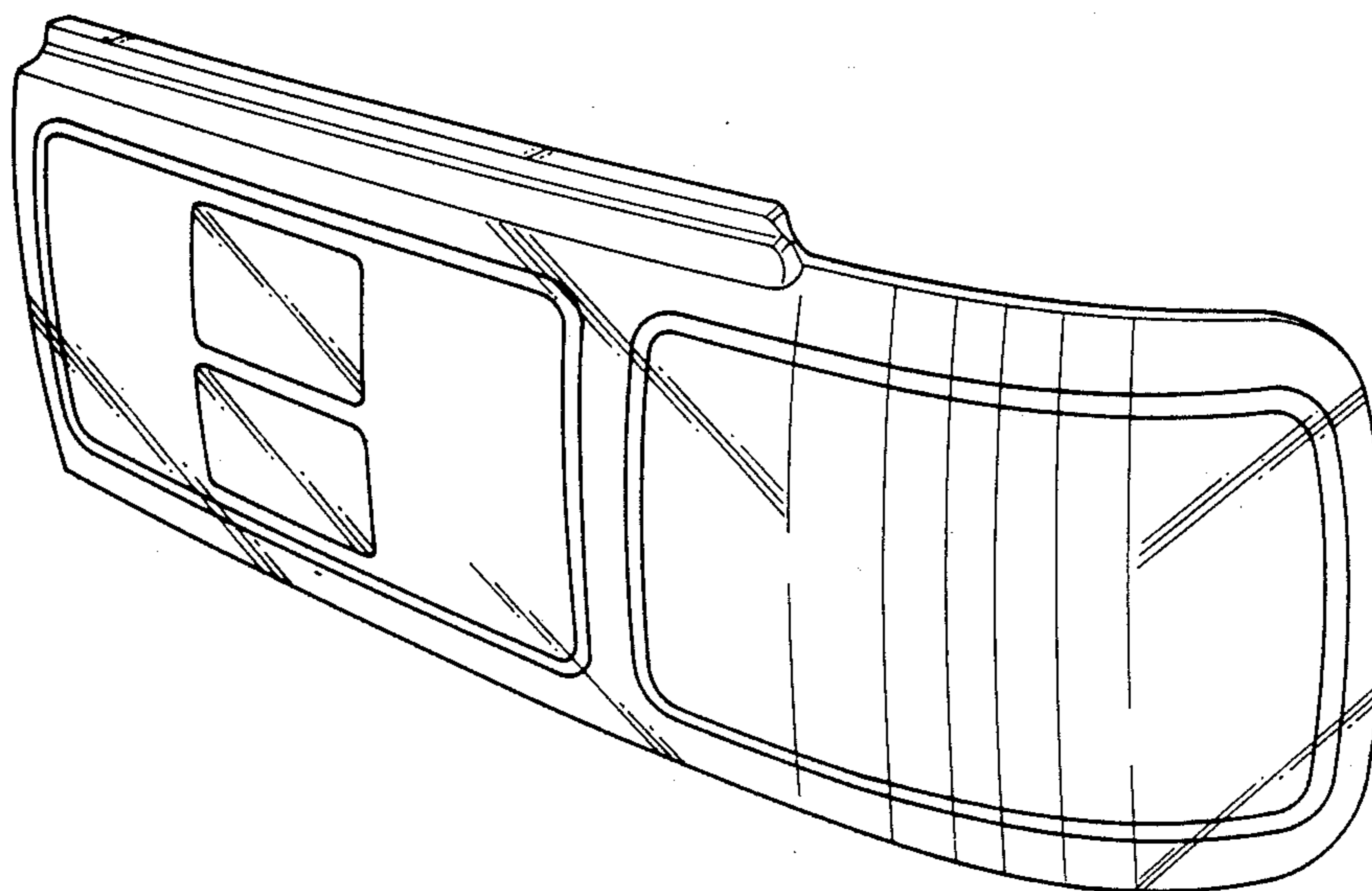

Fig. 1

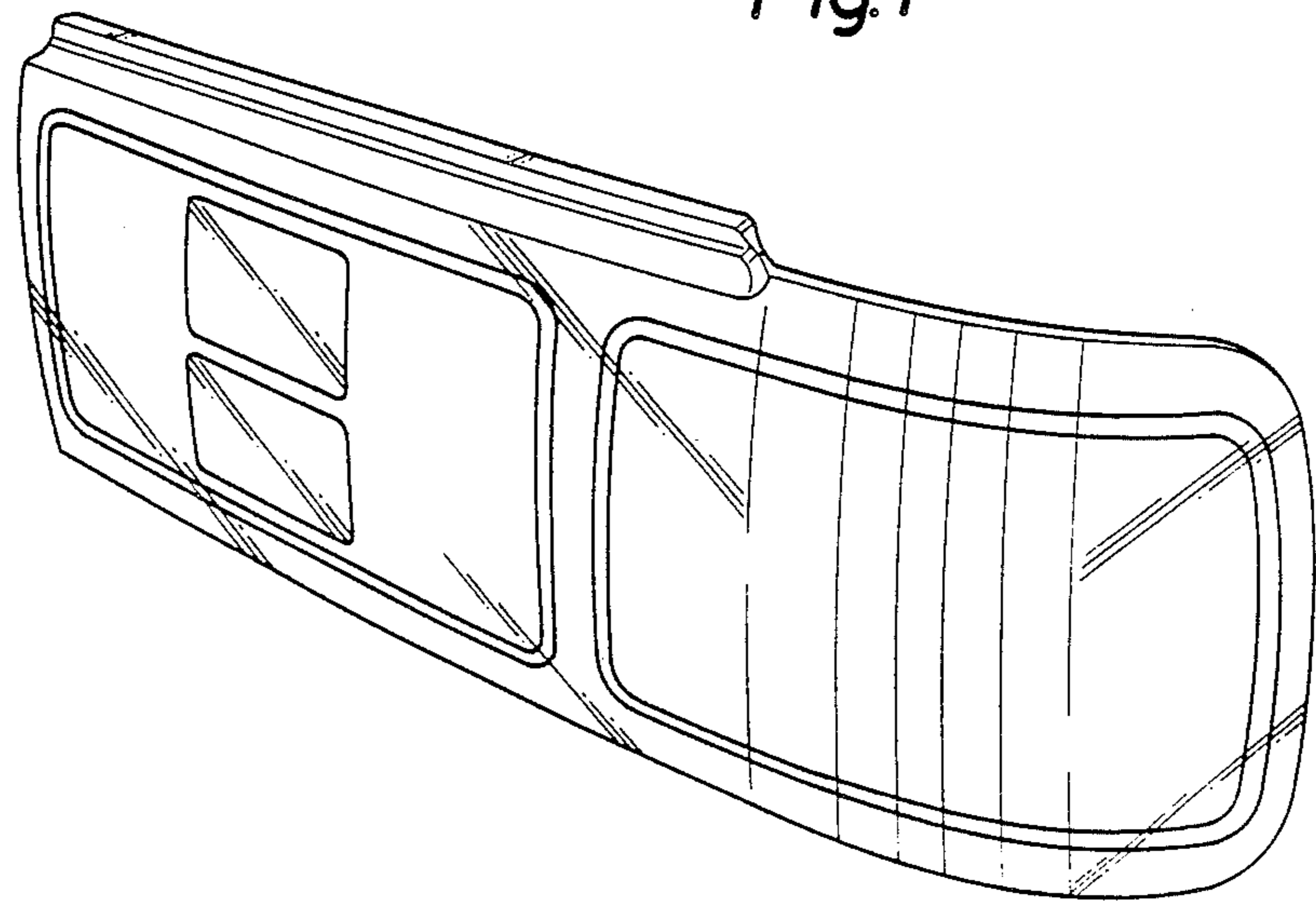

Fig. 2

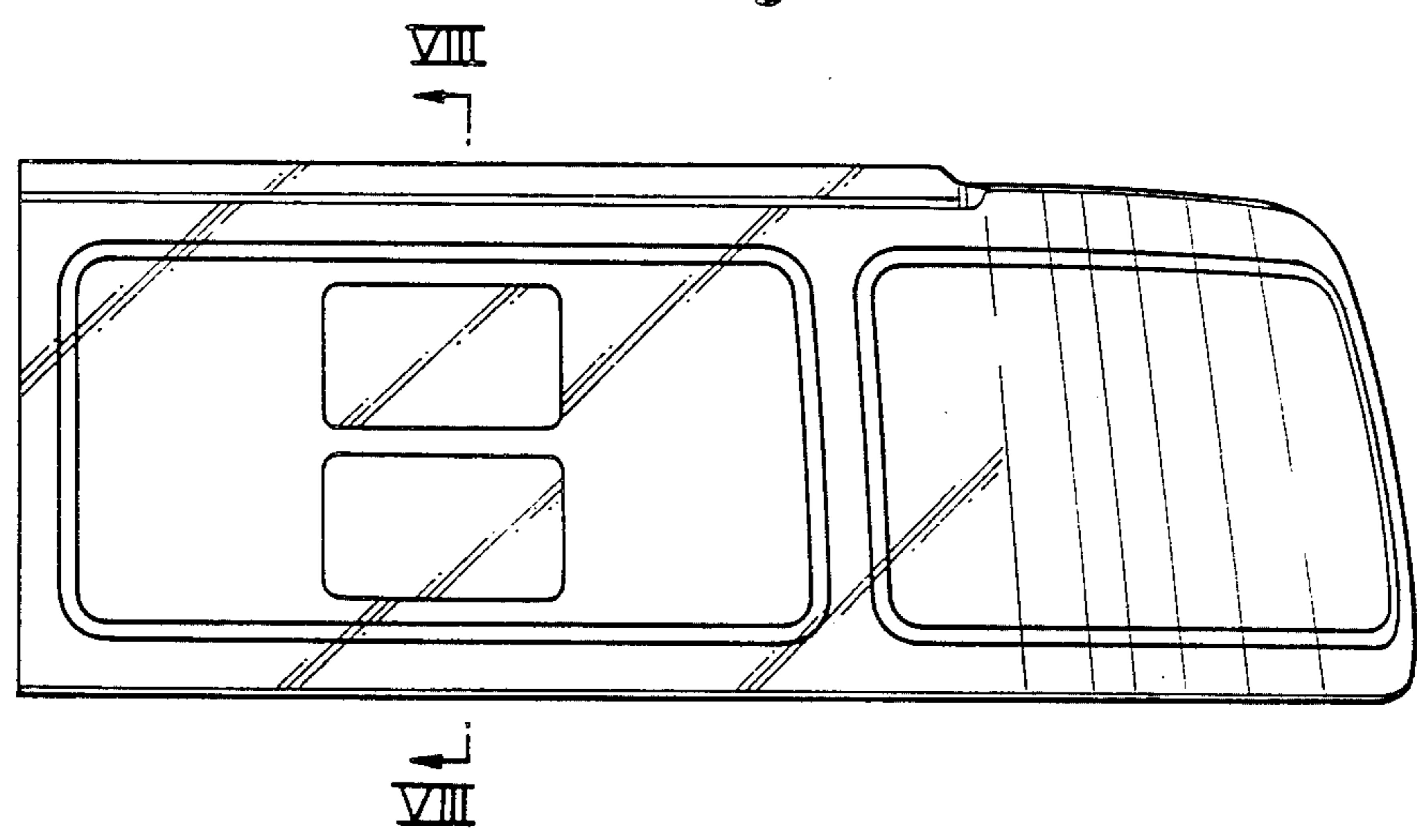

Fig.3

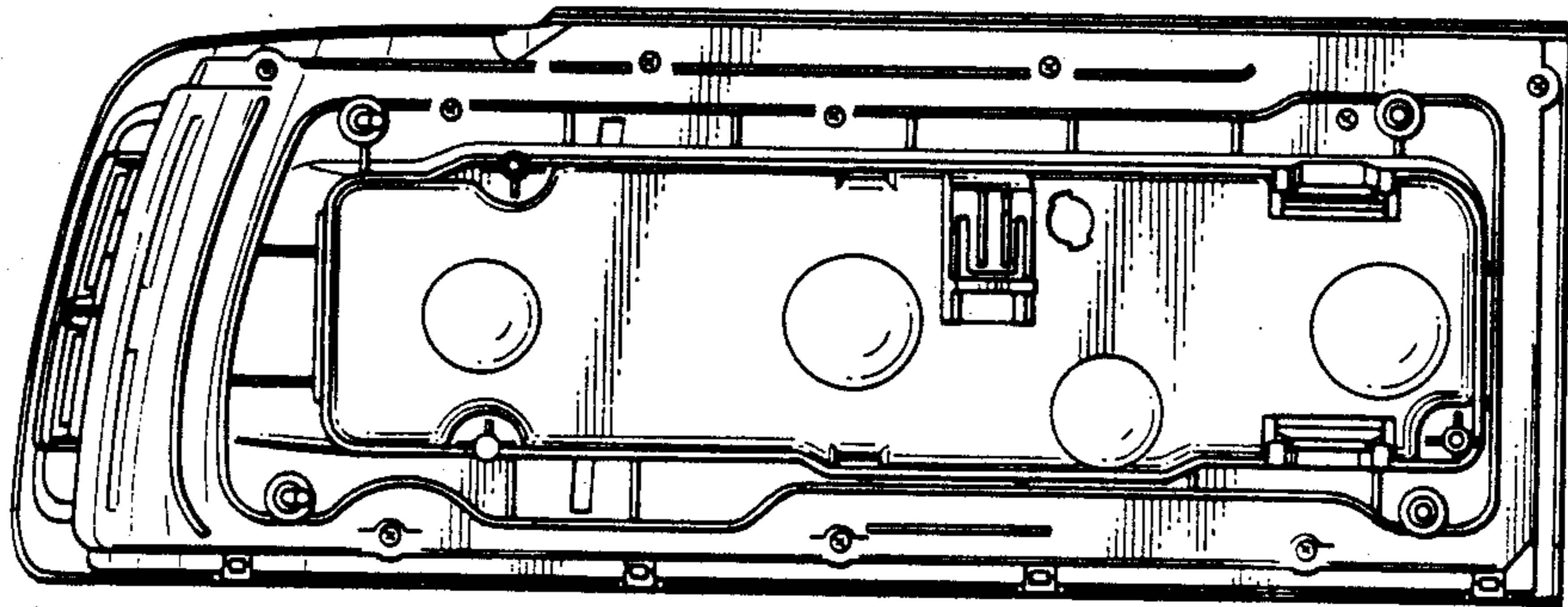

Fig.4

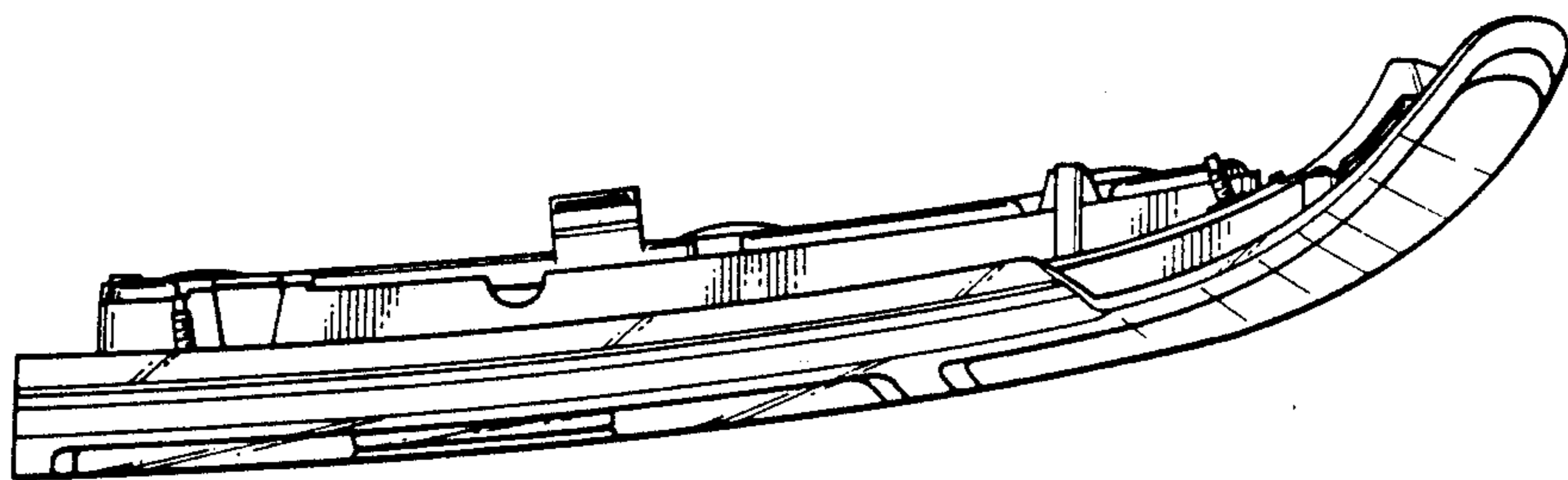

Fig. 5

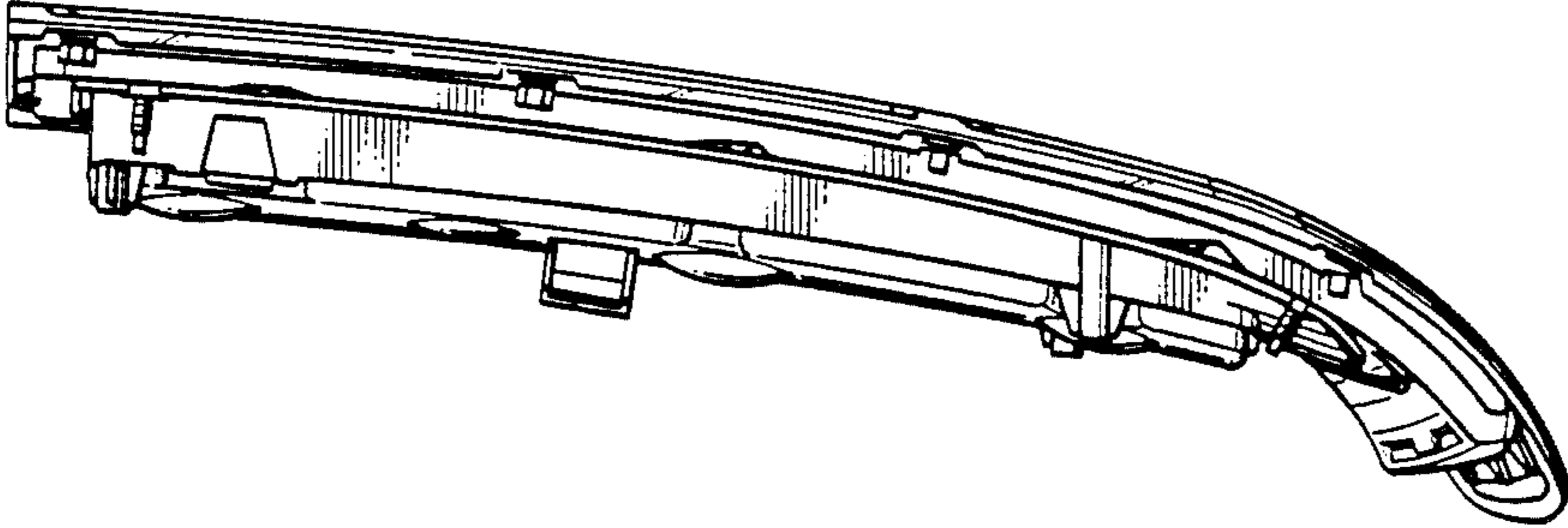

Fig. 6

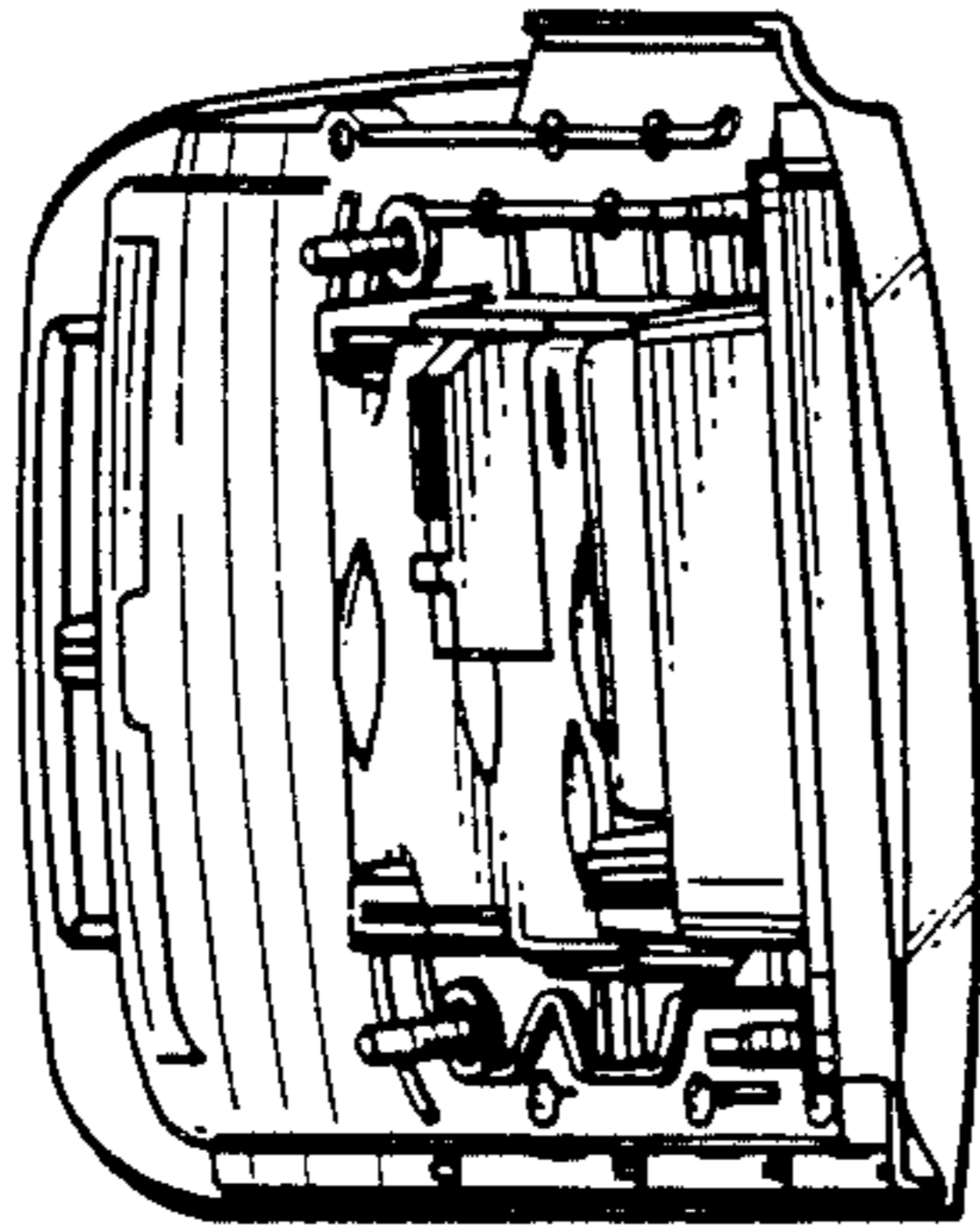

Fig. 7

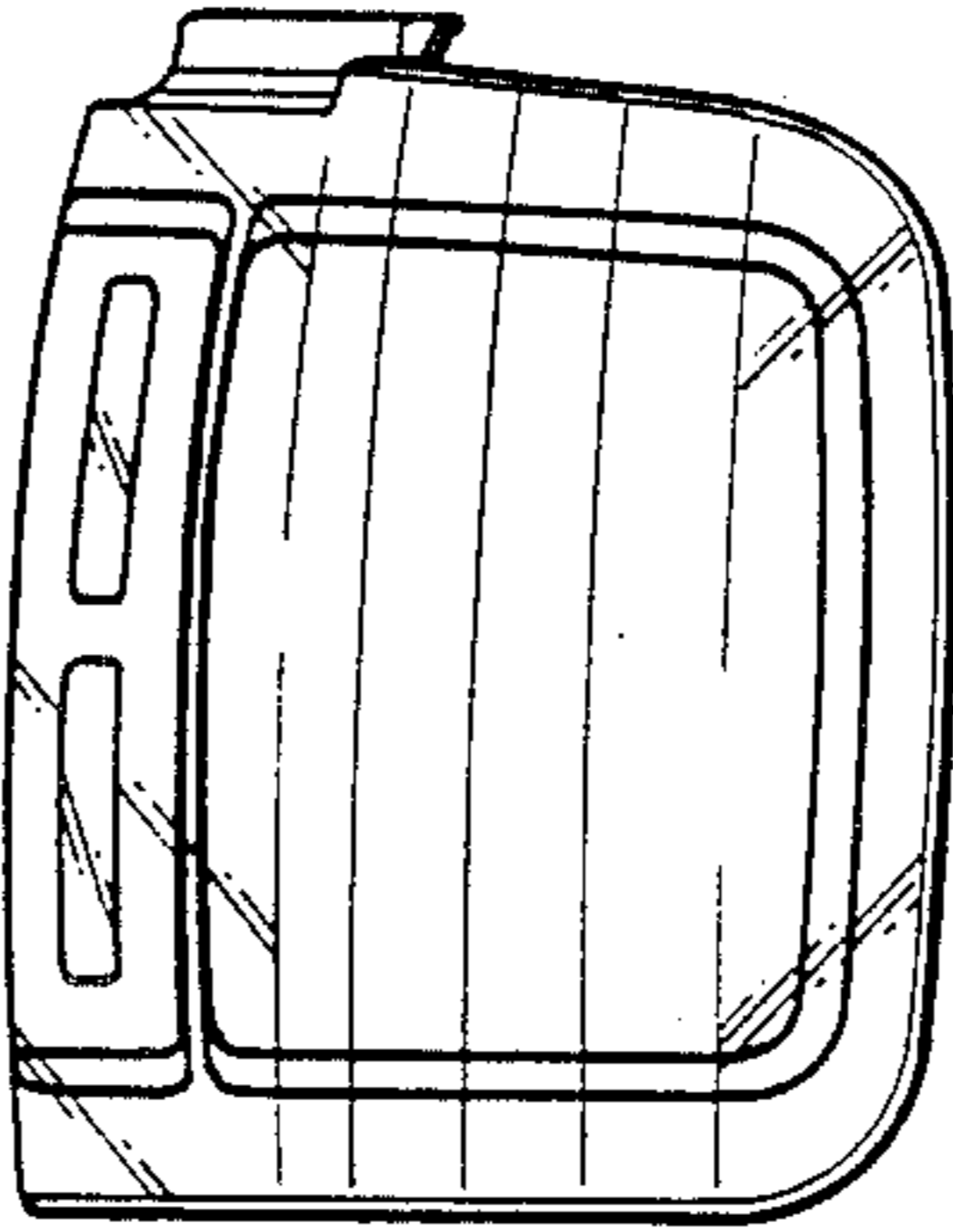

Fig. 8

