

[54] DETACHABLE PASSENGER COMPARTMENT FOR A GOLF CART

[75] Inventor: Gregory D. Cook, Duncan, Okla.

[73] Assignee: Cook Manufacturing Corporation, Duncan, Okla.

[**] Term: 14 Years

[21] Appl. No.: 691,051

[22] Filed: Jan. 14, 1985

[52] U.S. Cl. D12/156; D12/16

[58] Field of Search D12/156, 16; 296/78 R, 296/102; 135/88; D34/15

[56] References Cited

U.S. PATENT DOCUMENTS

131,591	3/1942	Keller	D15/23
162,116	2/1951	Barton	D15/30
916,439	3/1909	Grover	246/238
1,383,880	7/1921	Thomas	296/103
2,451,553	10/1948	Hedquist et al.	180/1
2,539,951	1/1951	Hall	296/102
2,789,863	4/1957	Shimabukuro	296/78
2,815,243	12/1957	Campbell	296/28
3,206,245	9/1965	Westrum et al.	296/102
3,333,888	8/1967	Williams et al.	296/102
3,414,316	12/1968	Williams et al.	296/28
3,572,819	3/1971	Moore et al.	296/102

3,690,720	9/1972	Whisler	296/28
3,709,553	1/1973	Churchill et al.	296/28
3,834,756	9/1974	Grell	296/136
3,866,969	2/1975	Sandrock et al.	296/28
3,881,769	5/1975	Metzke	296/39
4,098,536	7/1978	Mills	296/78
4,184,712	1/1980	Skahill	296/190
4,221,274	9/1980	Martin, Jr.	180/69
4,336,964	6/1982	Pivar	296/78
4,621,859	11/1986	Spicher	D34/15

Primary Examiner—James M. Gandy
Assistant Examiner—Kay H. Chin
Attorney, Agent, or Firm—Dunlap, Coddling & Peterson

[57] CLAIM

The ornamental design for a detachable passenger compartment for a golf cart, as shown and described.

DESCRIPTION

FIG. 1 is a perspective view of a detachable passenger compartment for a golf cart showing my new design; the broken lines are for illustrative purposes only and form no part of the design;
FIG. 2 is a left side elevational view thereof;
FIG. 3 is a right side elevational view thereof;
FIG. 4 is a top plan view thereof;
FIG. 5 is a bottom plan view thereof;
FIG. 6 is a front elevational view thereof; and
FIG. 7 is a rear elevational view thereof.

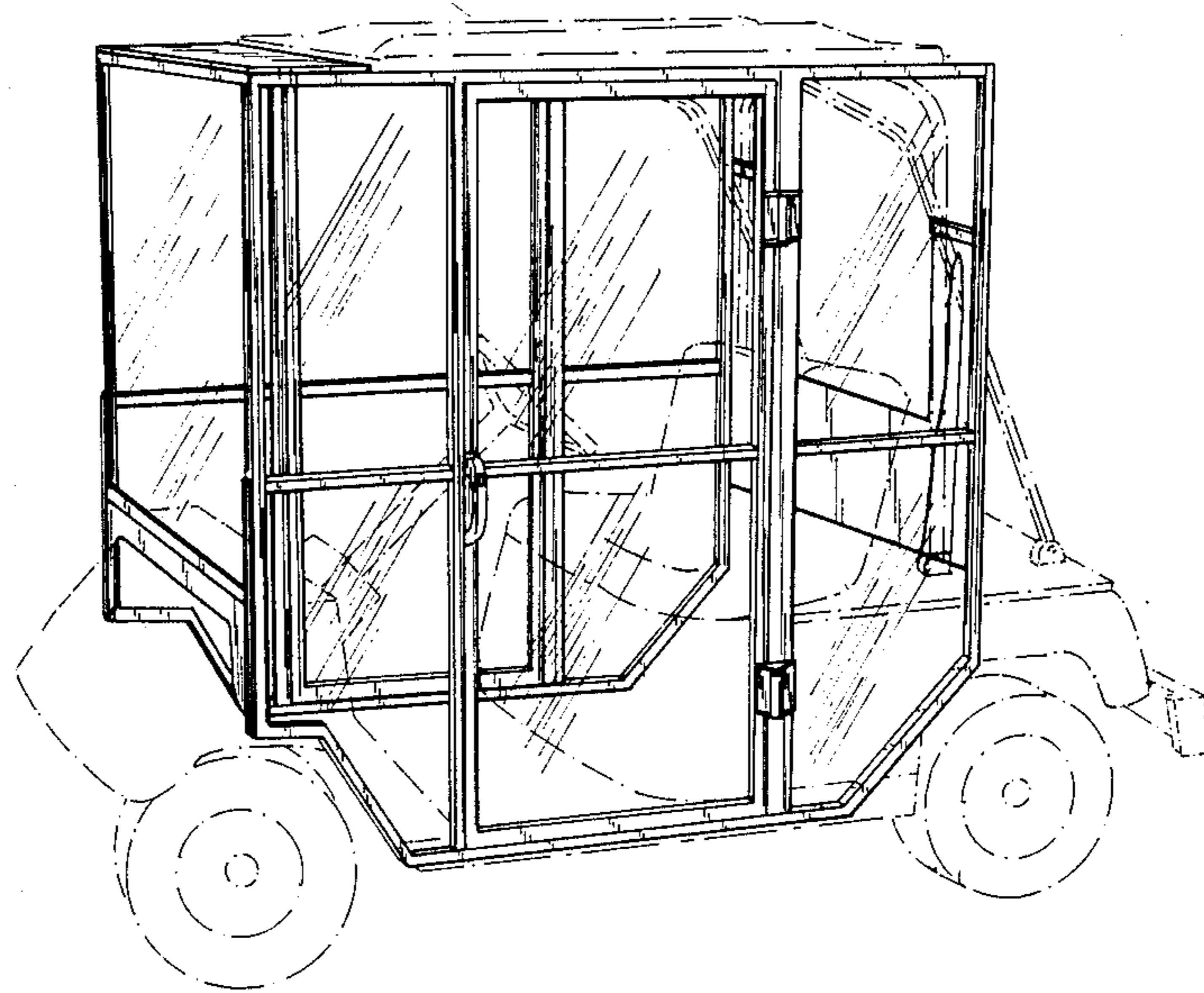

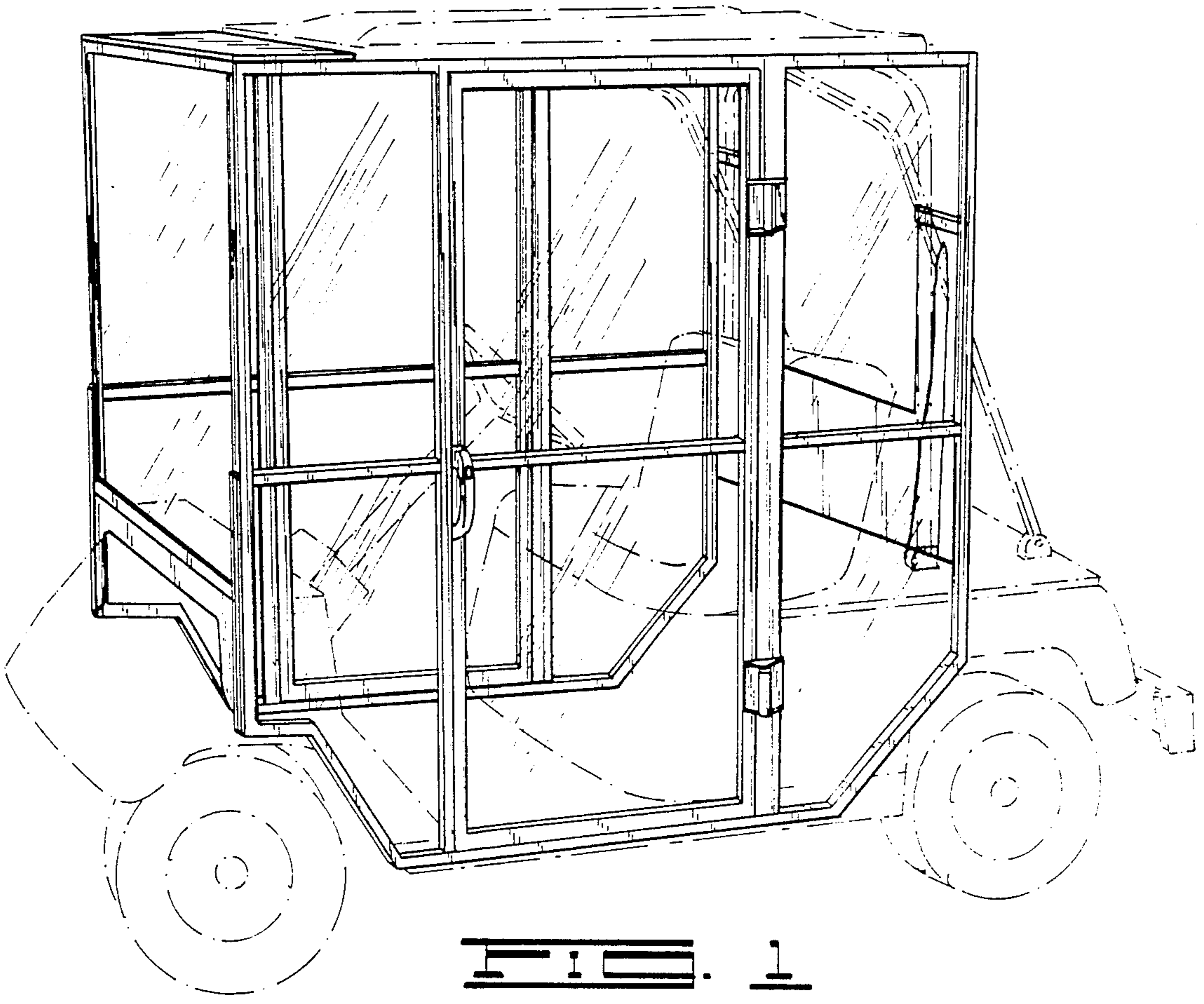

FIG. 1

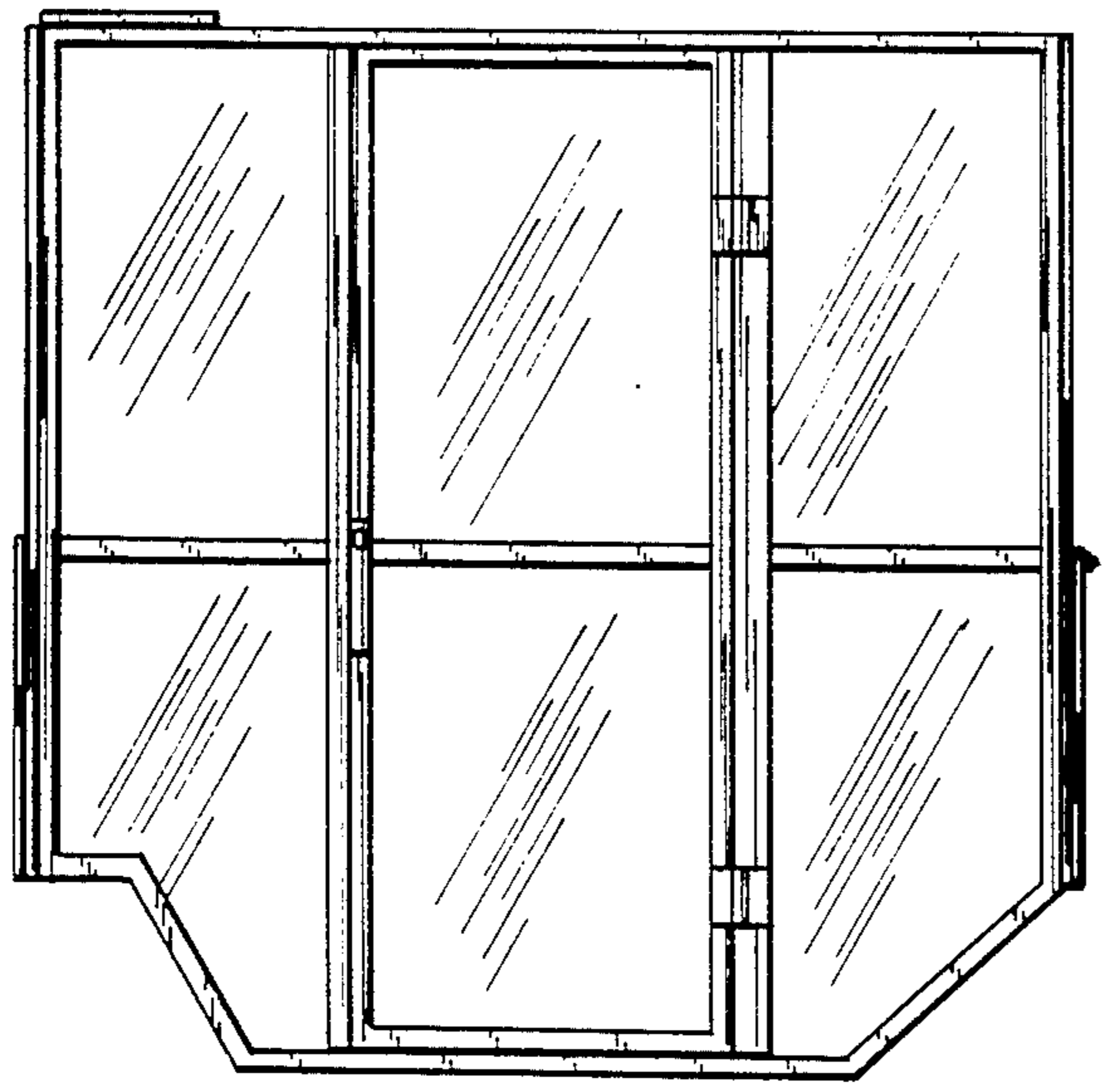

FIG. 2

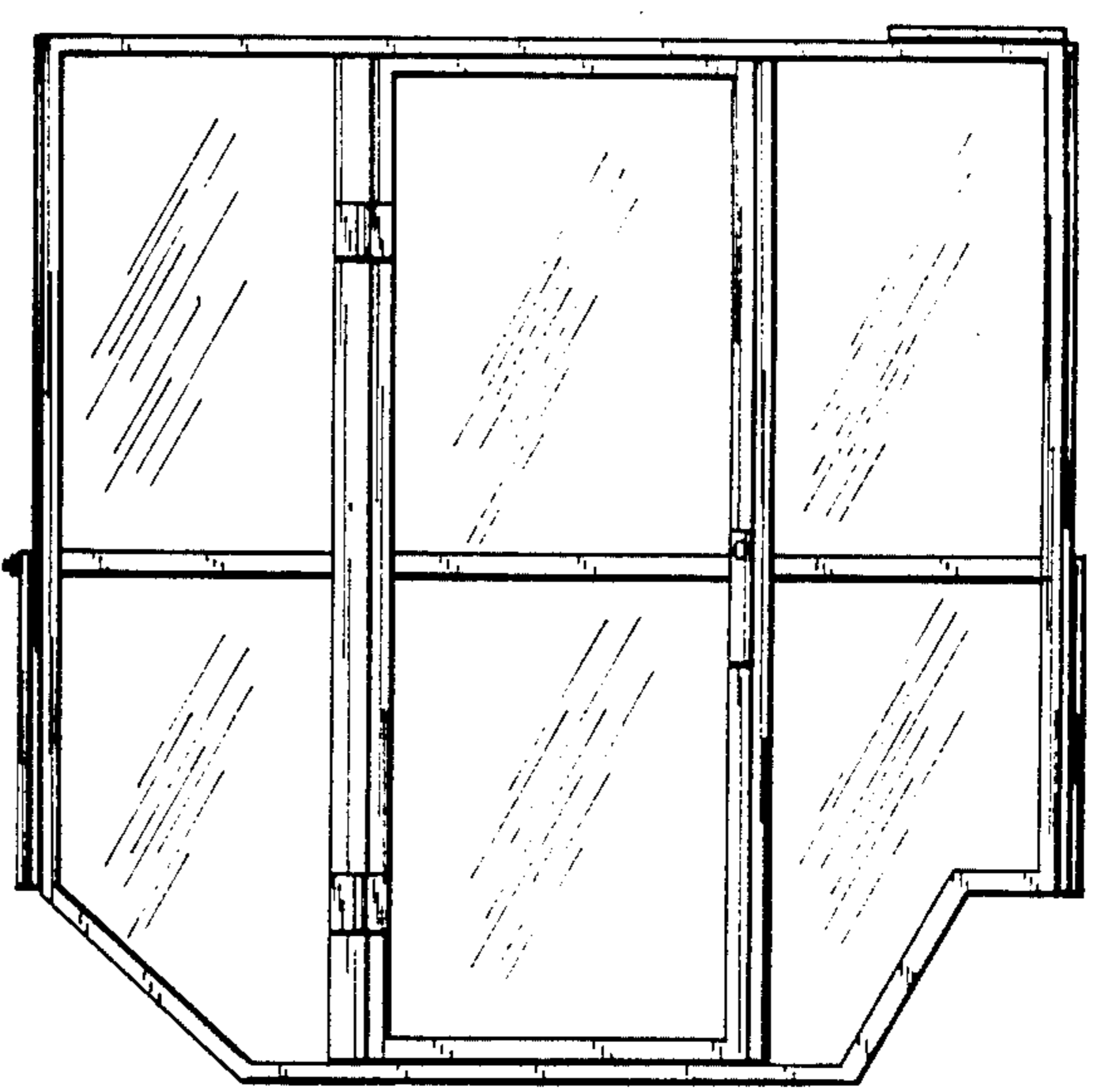

FIG. 3

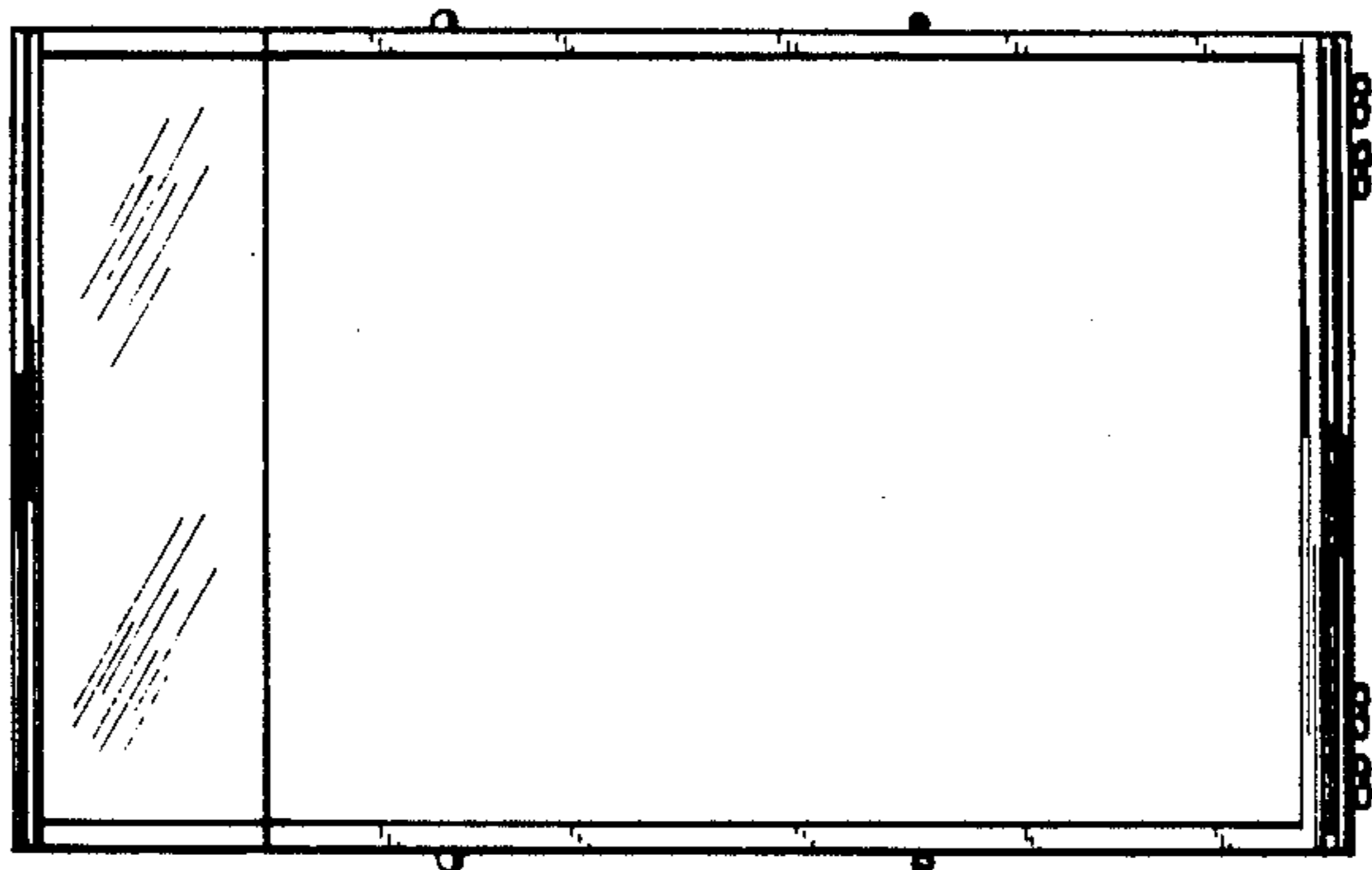

FIG. 4

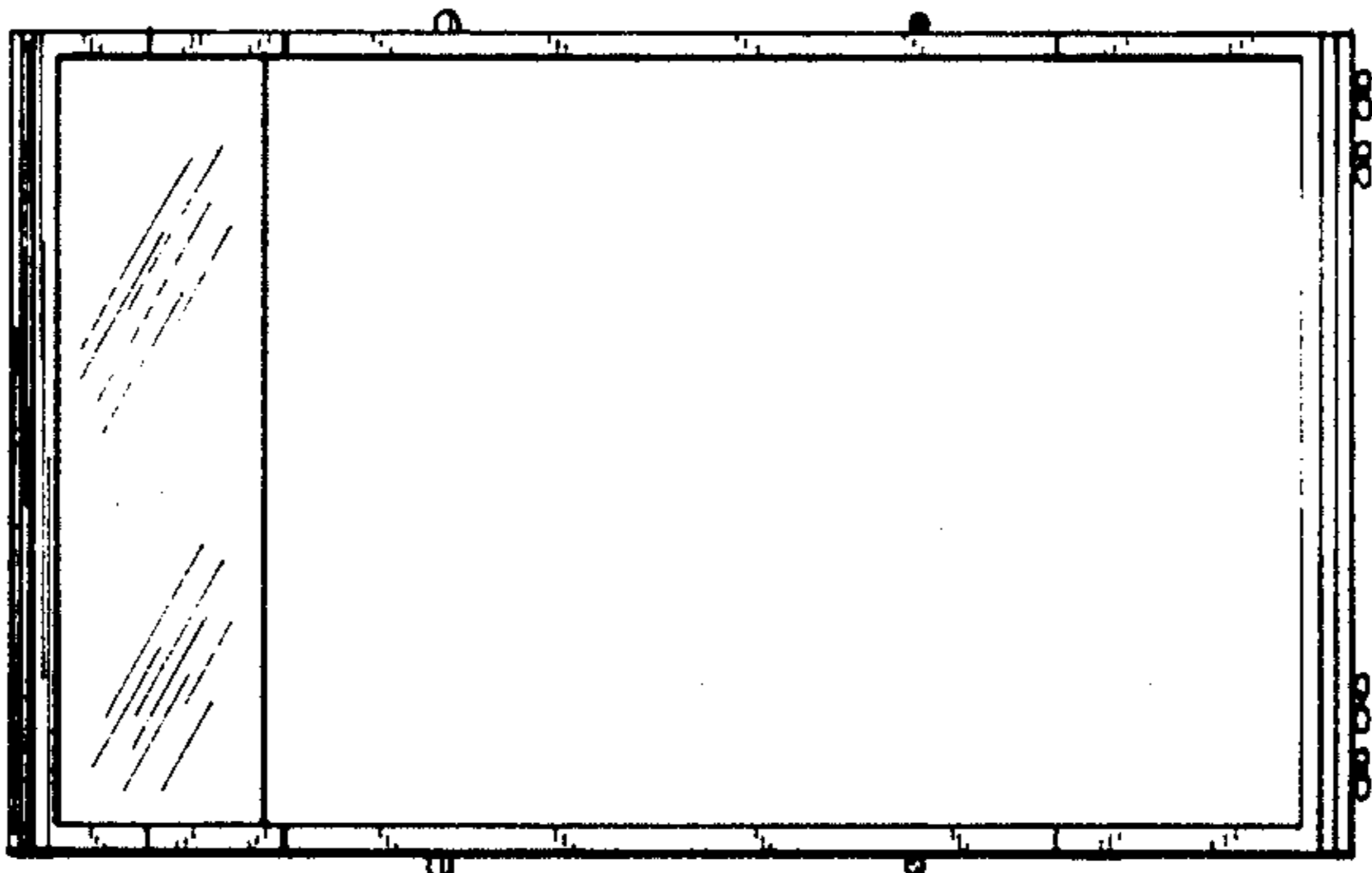

FIG. 5

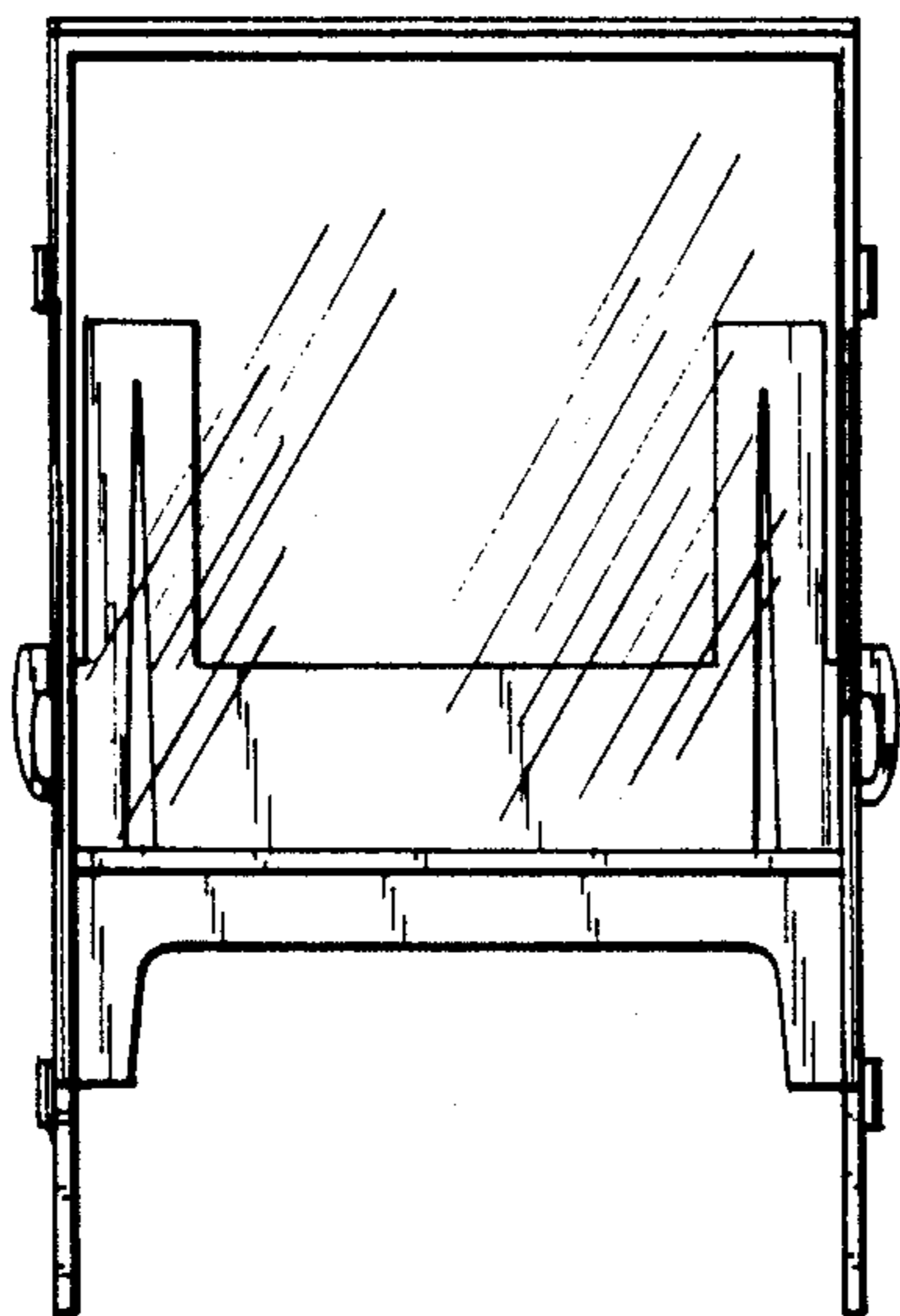

FIG. 6

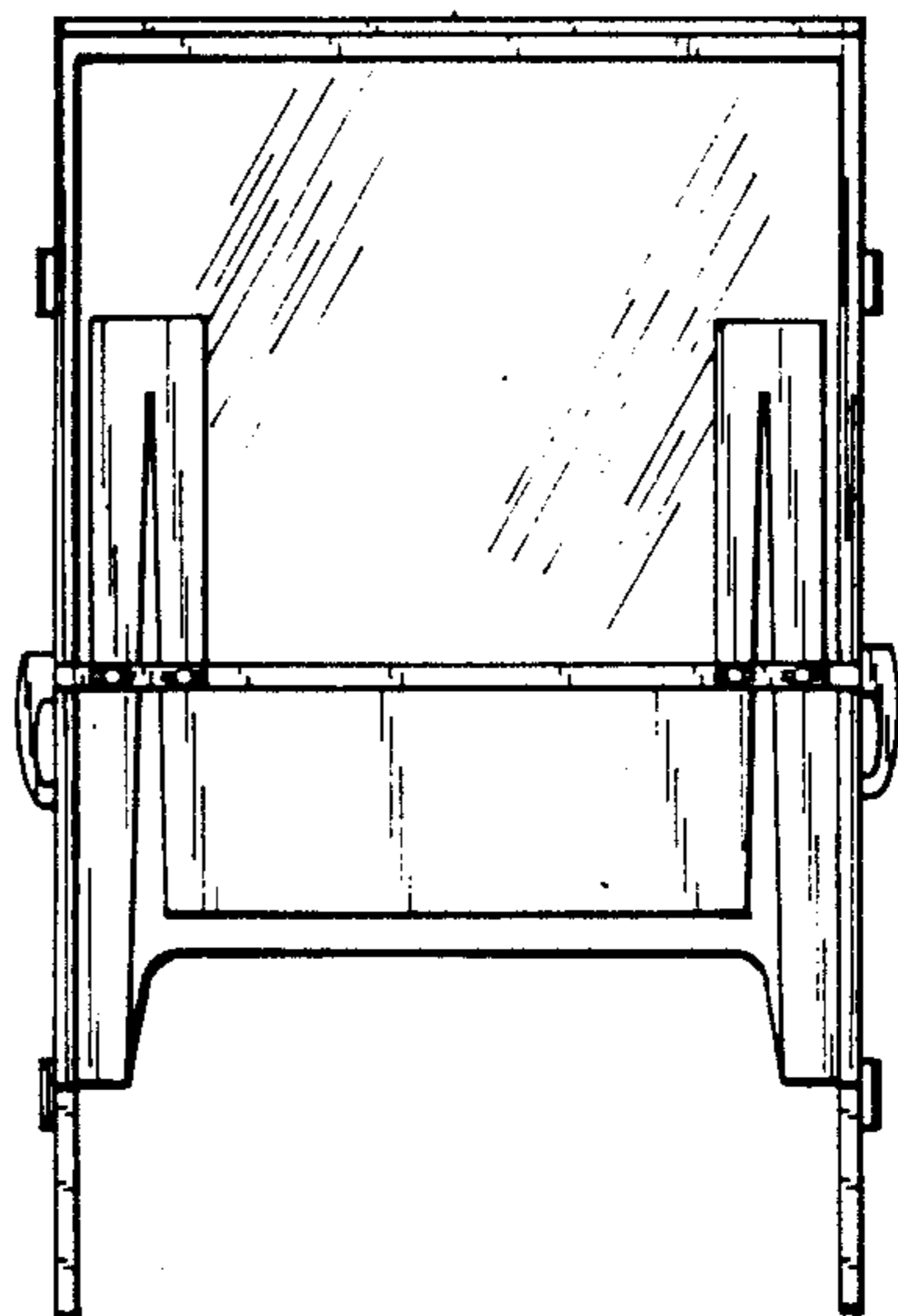

FIG. 7