

[54] VEHICLE WHEEL CENTER

D. 287,960 1/1987 Boyer D12/211

[75] Inventor: Donald J. Reid, Plymouth, Mich.

Primary Examiner—James M. Gandy
Attorney, Agent, or Firm—Ralph J. Skinkiss; David L. Kuhn

[73] Assignee: Kelsey-Hayes Company, Romulus, Mich.

[**] Term: 14 Years

[57] CLAIM

The ornamental design for a vehicle wheel center, as shown and described.

[21] Appl. No.: 769,514

[22] Filed: Aug. 26, 1985

[52] U.S. Cl. D12/209

[58] Field of Search D12/209, 210, 211;
301/37 R, 63 R, 64 R, 64 SD, 65

DESCRIPTION

FIG. 1 is a front elevational view of a vehicle wheel center showing my new design.

FIG. 2 is a sectional view taken along line 2—2 in FIG. 1.

FIG. 3 is a sectional view taken along line 3—3 in FIG. 1.

FIG. 4 is a sectional view taken along line 4—4 in FIG. 1.

FIG. 5 is a sectional view taken along line 5—5 in FIG. 1.

The broken lines in the drawing are for illustrative purposes only and form no part of the claimed design.

[56] References Cited

U.S. PATENT DOCUMENTS

D. 54,681	3/1920	Romney	D12/210
D. 173,666	12/1954	Mason	D12/210
D. 229,558	12/1973	Brainard et al.	D12/211
D. 235,328	6/1975	Scriver	D12/211
D. 271,760	12/1983	Zimmermann et al.	D12/209
D. 286,145	10/1986	Sandberg	D12/211

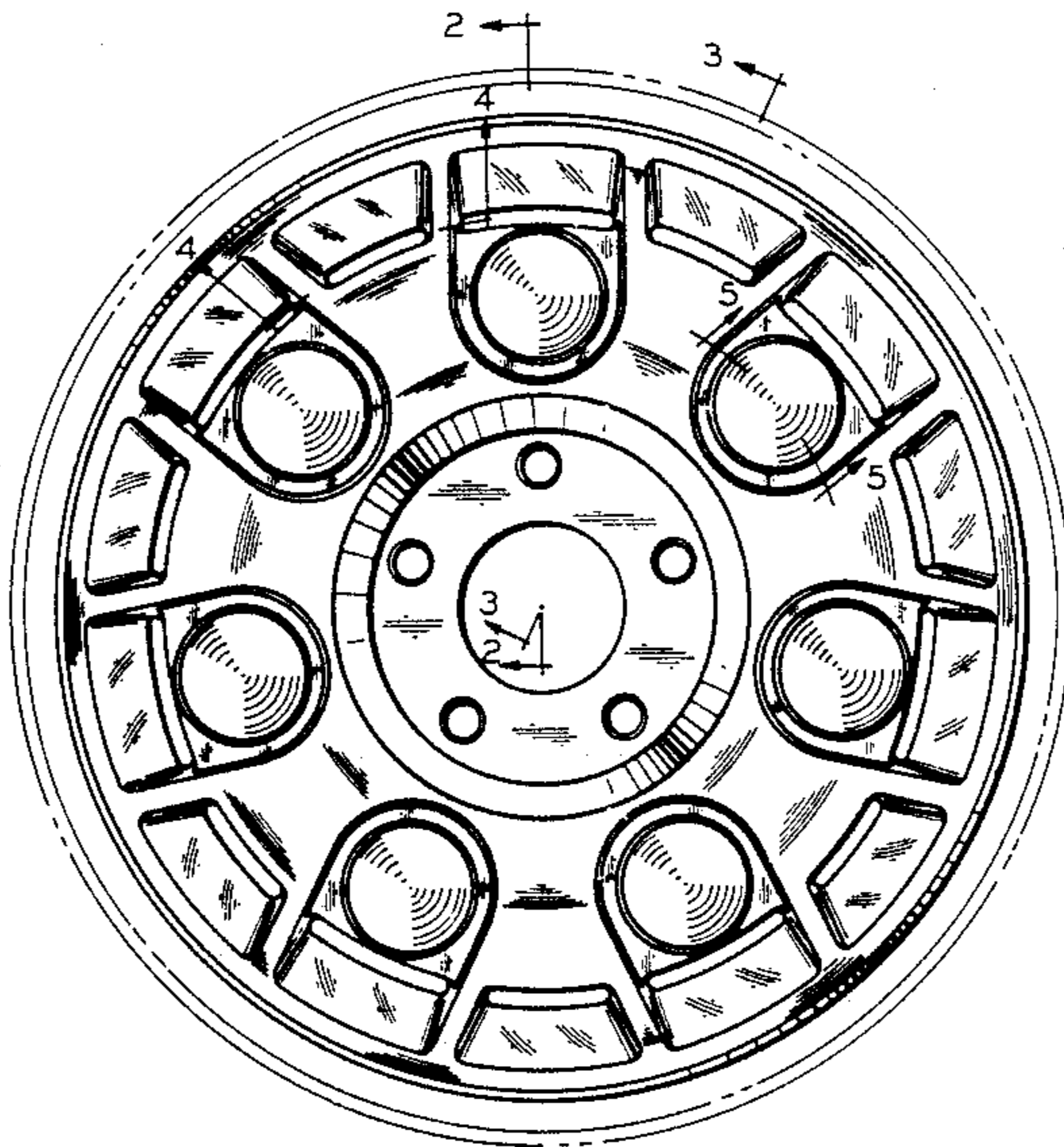

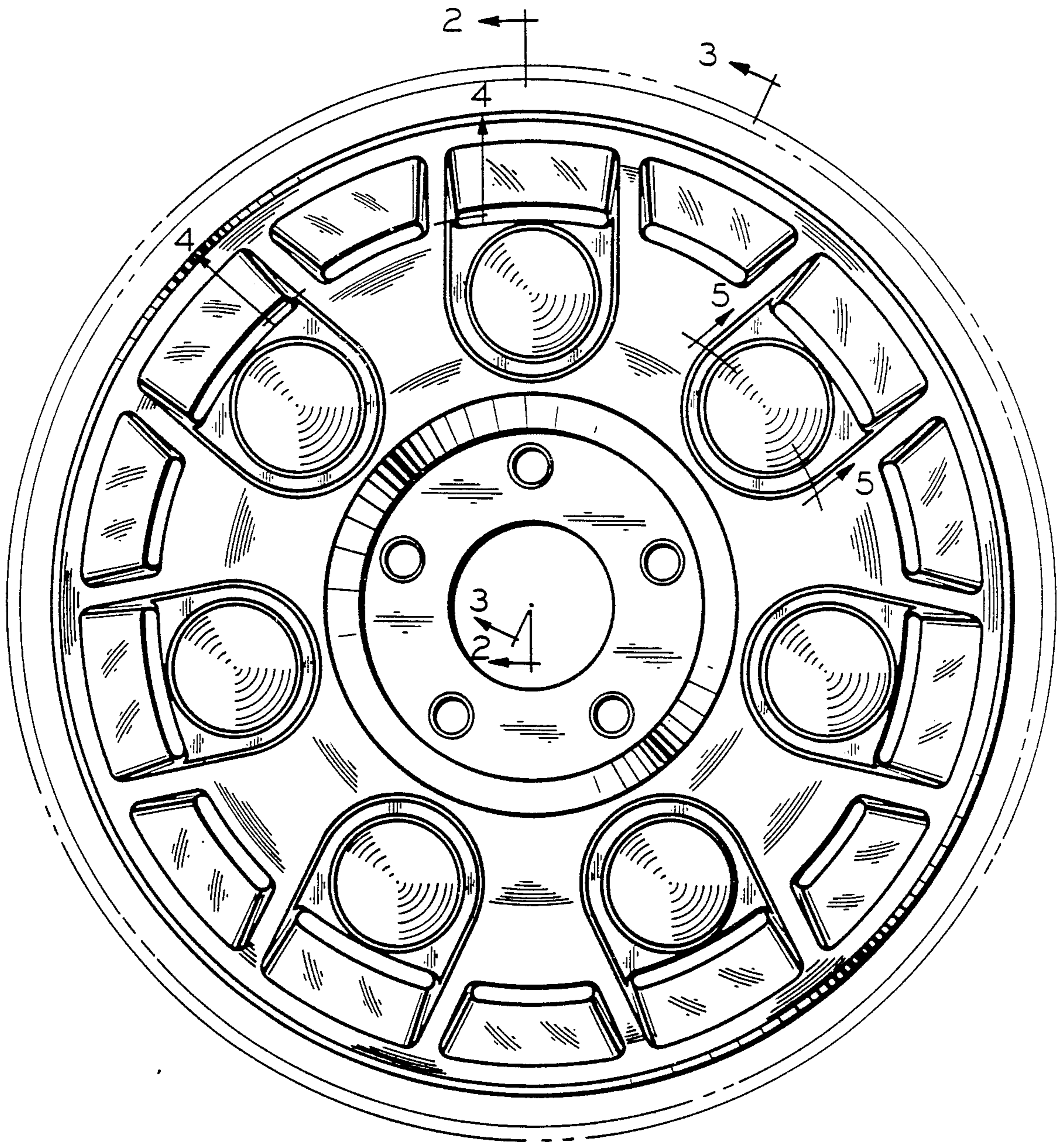

—FIG. 1

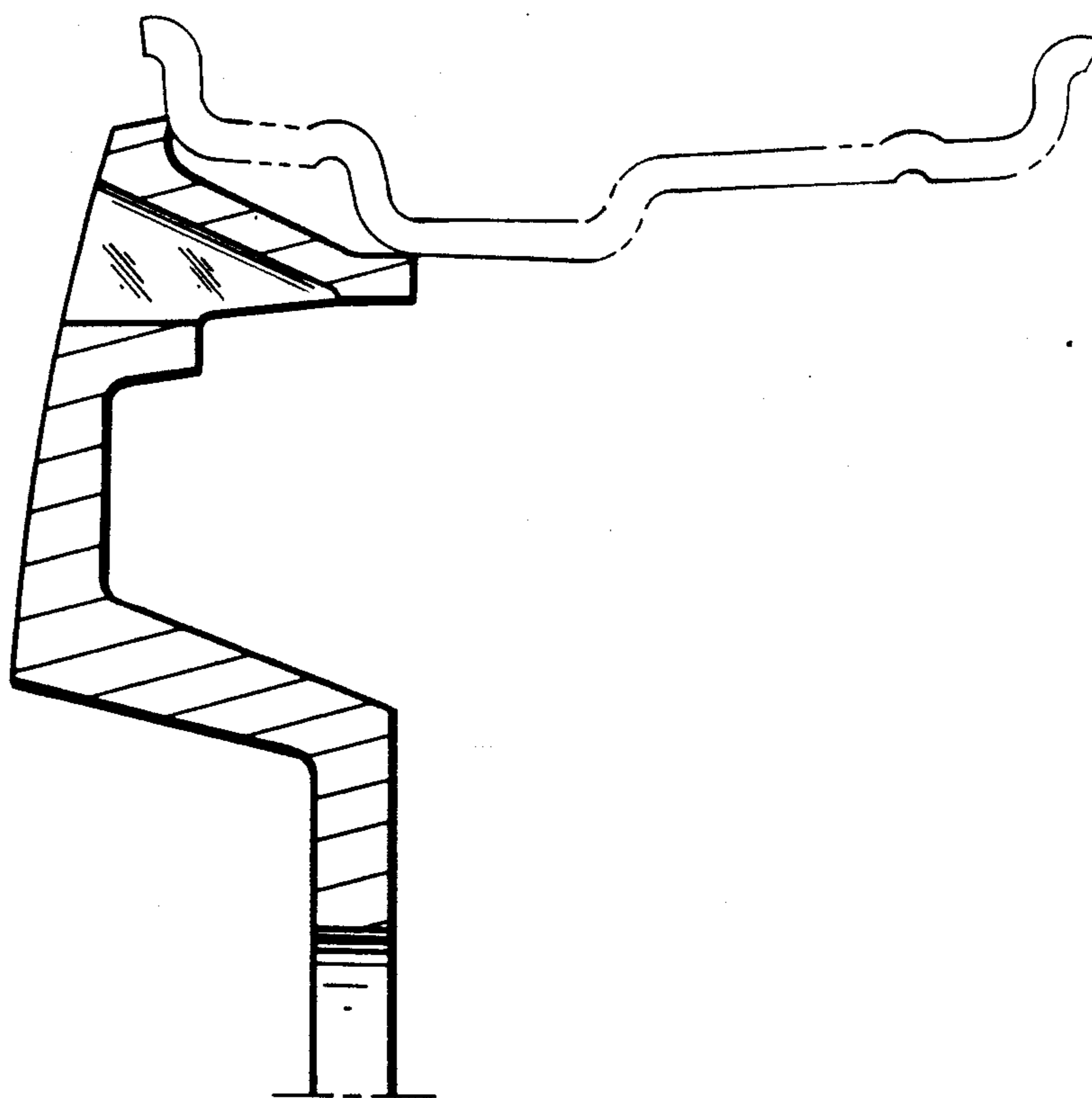
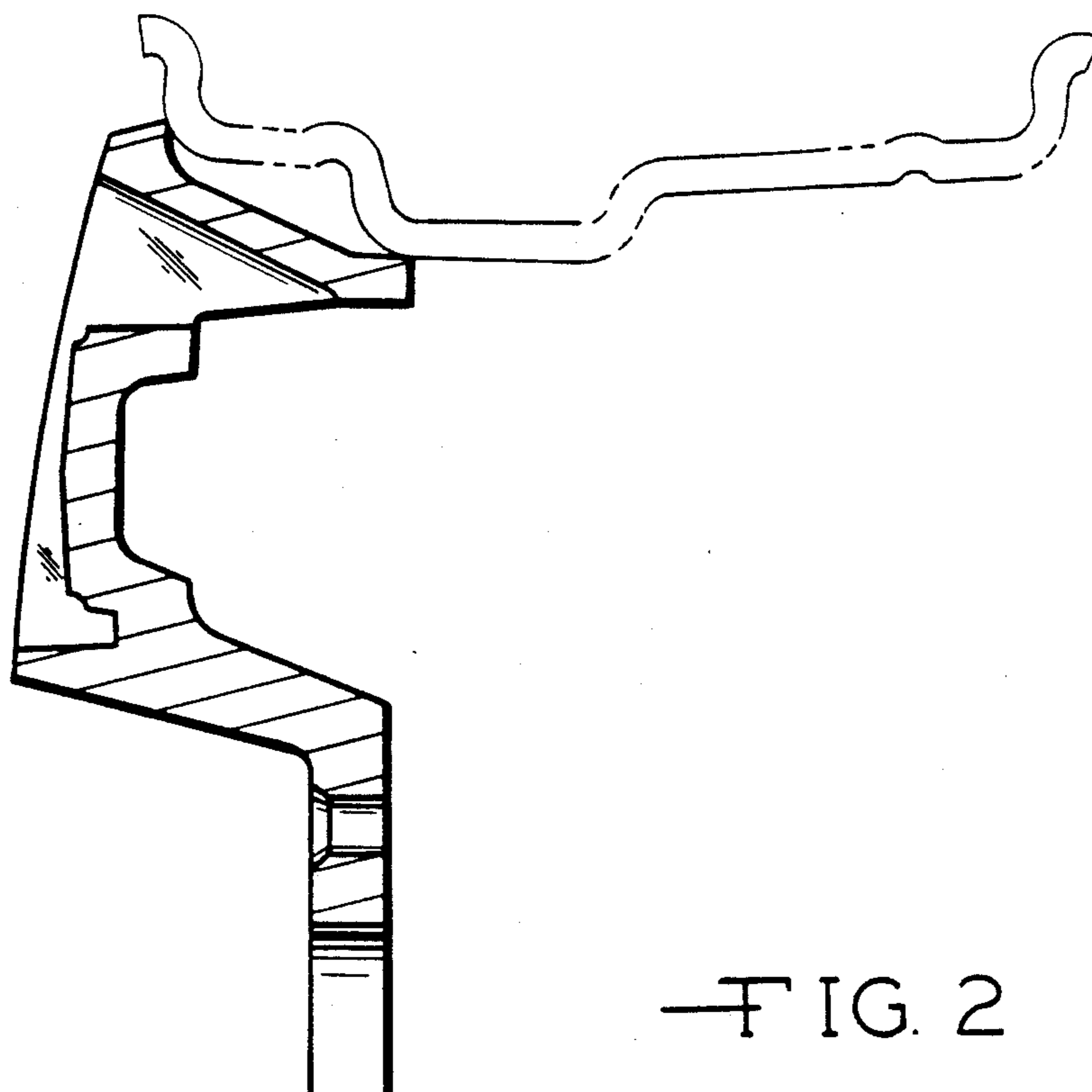

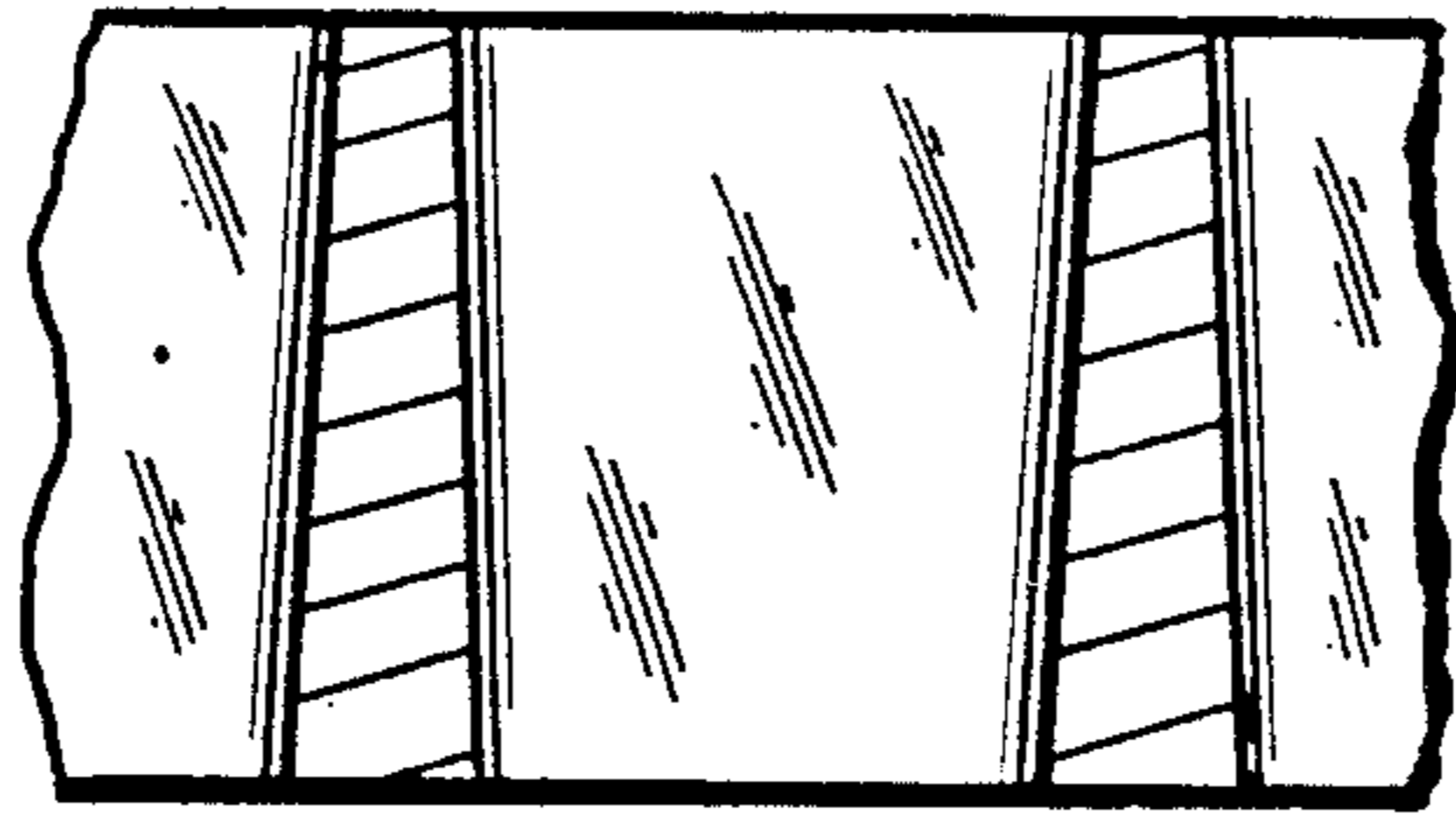

FIG. 4

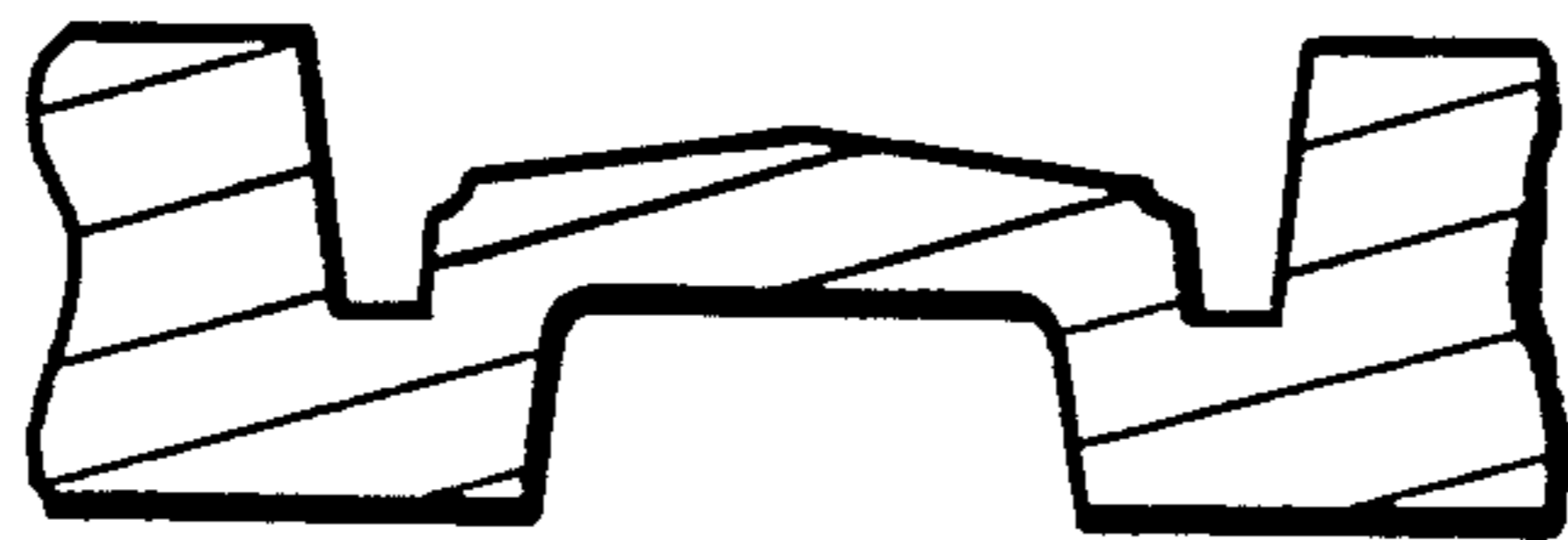

FIG. 5