

[54] TRUCK CAB

[75] Inventor: Robert E. Smith, Orem, Utah

[73] Assignee: Pegasus Truck Cab Conversions, Inc., Orem, Utah

[\*\*] Term: 14 Years

[21] Appl. No.: 736,641

[22] Filed: May 21, 1985

[52] U.S. Cl. .... D12/96

[58] Field of Search ..... D12/96, 97; 296/190; 180/89.12, 89.14, 89.16, 89.17, 89.18, 89.19

[56] References Cited

U.S. PATENT DOCUMENTS

D. 242,996 1/1977 Servais et al. .... D12/97

OTHER PUBLICATIONS

Commercial Car Journal, 1/78, p. 157, Truck cab.

Primary Examiner—James M. Gandy

Attorney, Agent, or Firm—Workman, Nydegger & Jensen

[57] CLAIM

The ornamental design for a truck cab, as shown and described.

DESCRIPTION

FIG. 1 is a perspective view of a truck cab showing my new design, it being understood that the broken lines are for illustrative purposes only and form no part of the claimed design;

FIG. 2 is a front elevational view thereof;

FIG. 3 is a top plan view thereof;

FIG. 4 is a side elevation view thereof, the opposite side being a mirror image of that shown;

FIG. 5 is a bottom plan view; and

FIG. 6 is a back elevational view thereof.

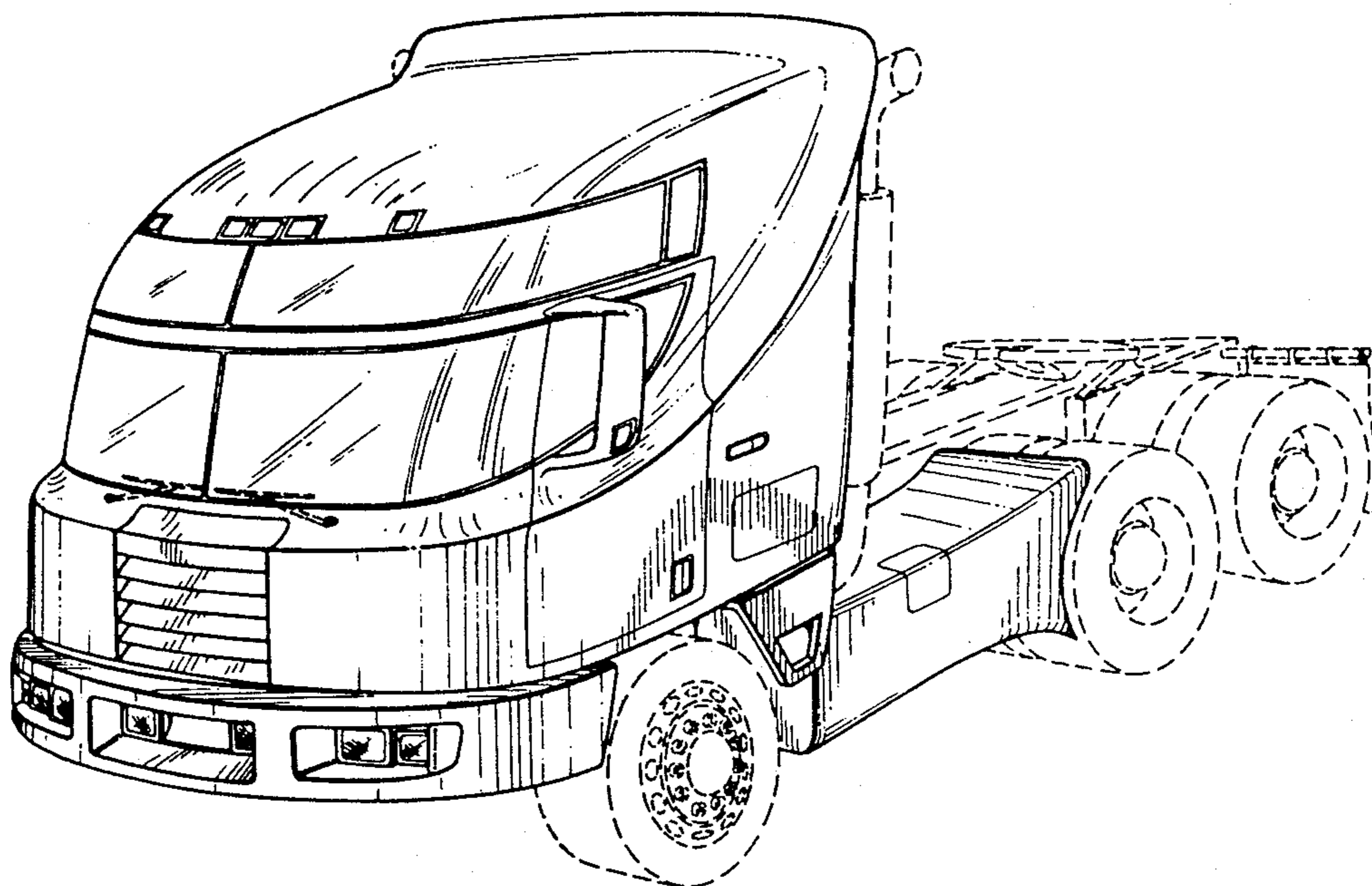

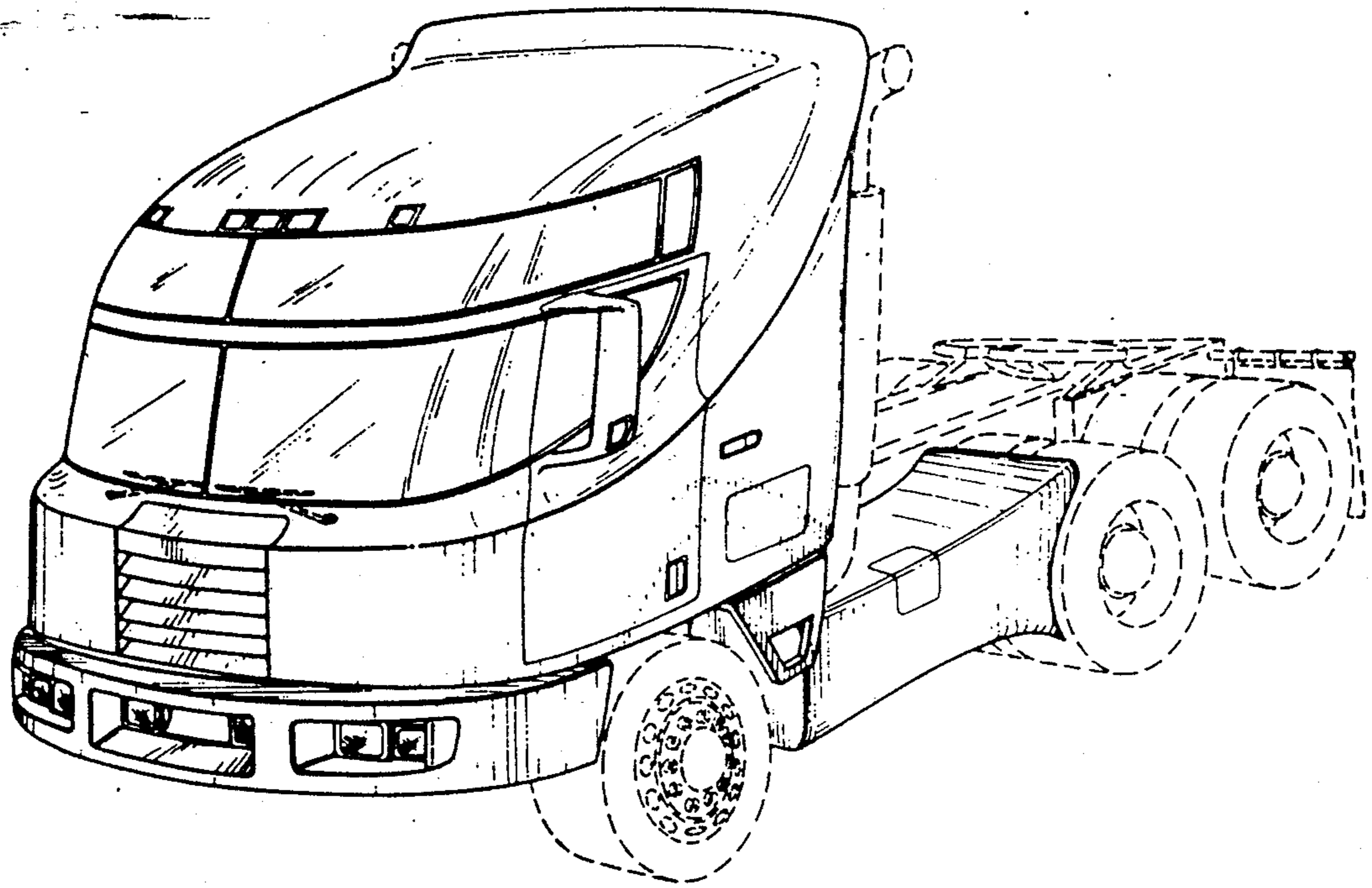

FIG. 1

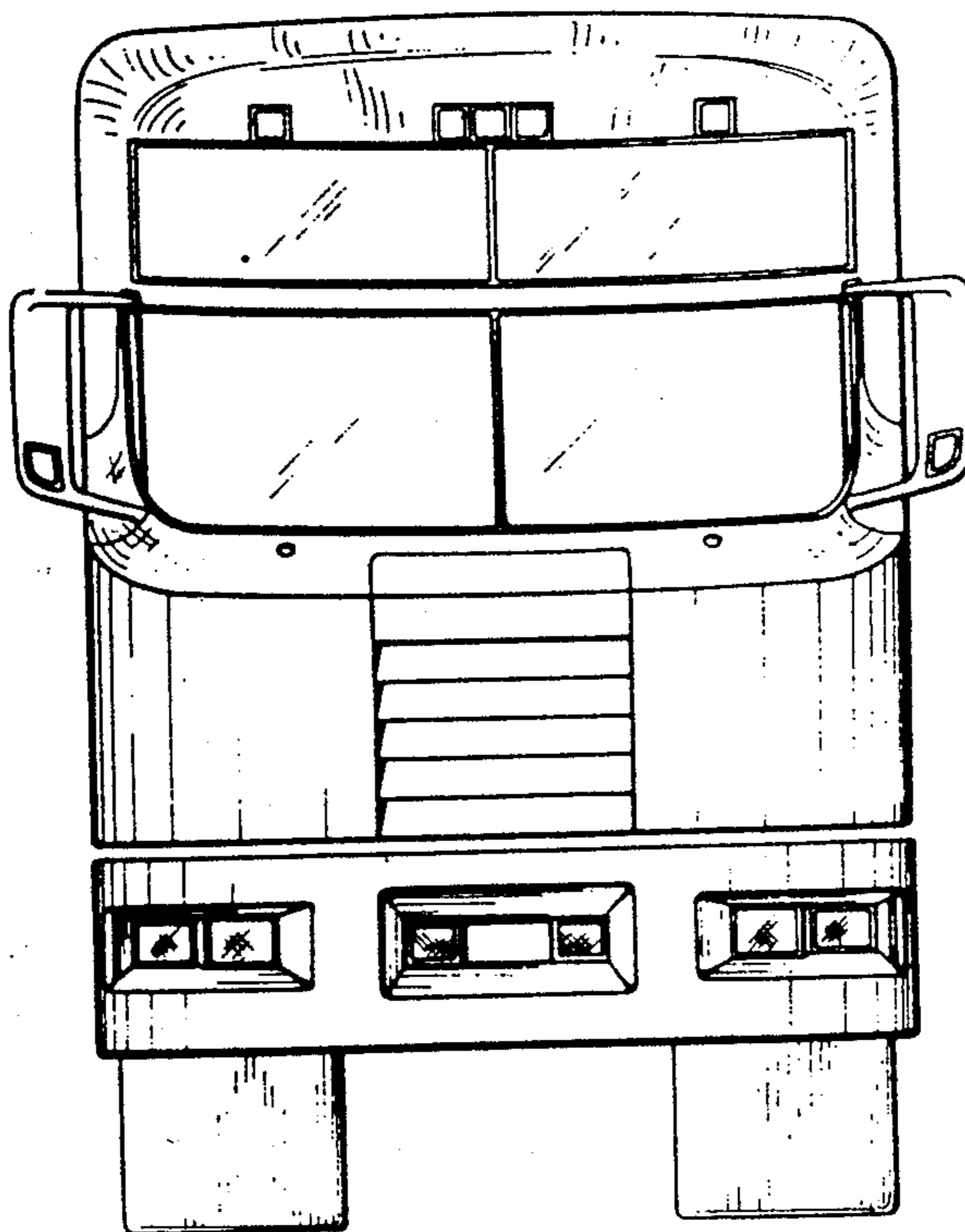

FIG. 2

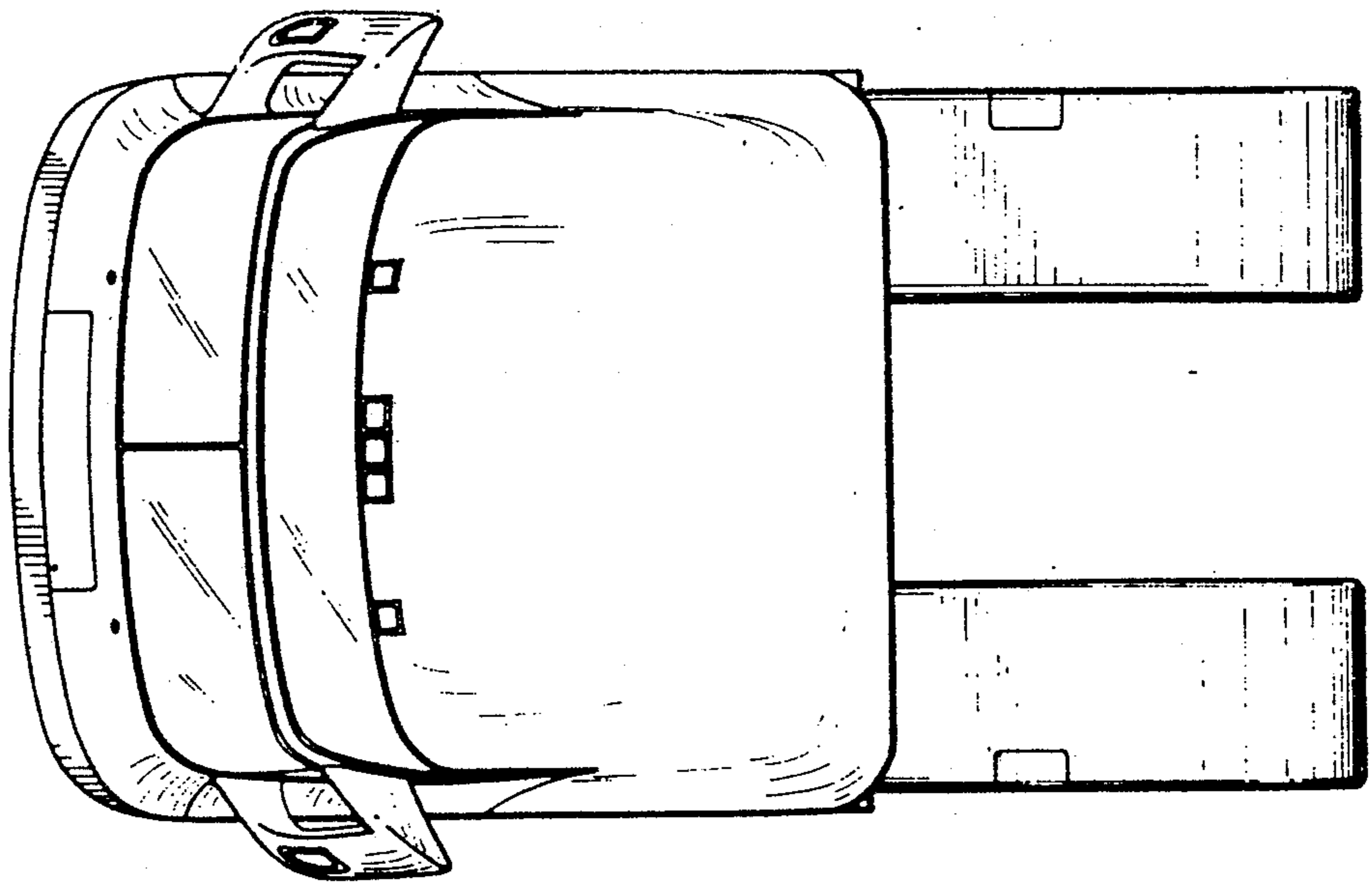

FIG. 3

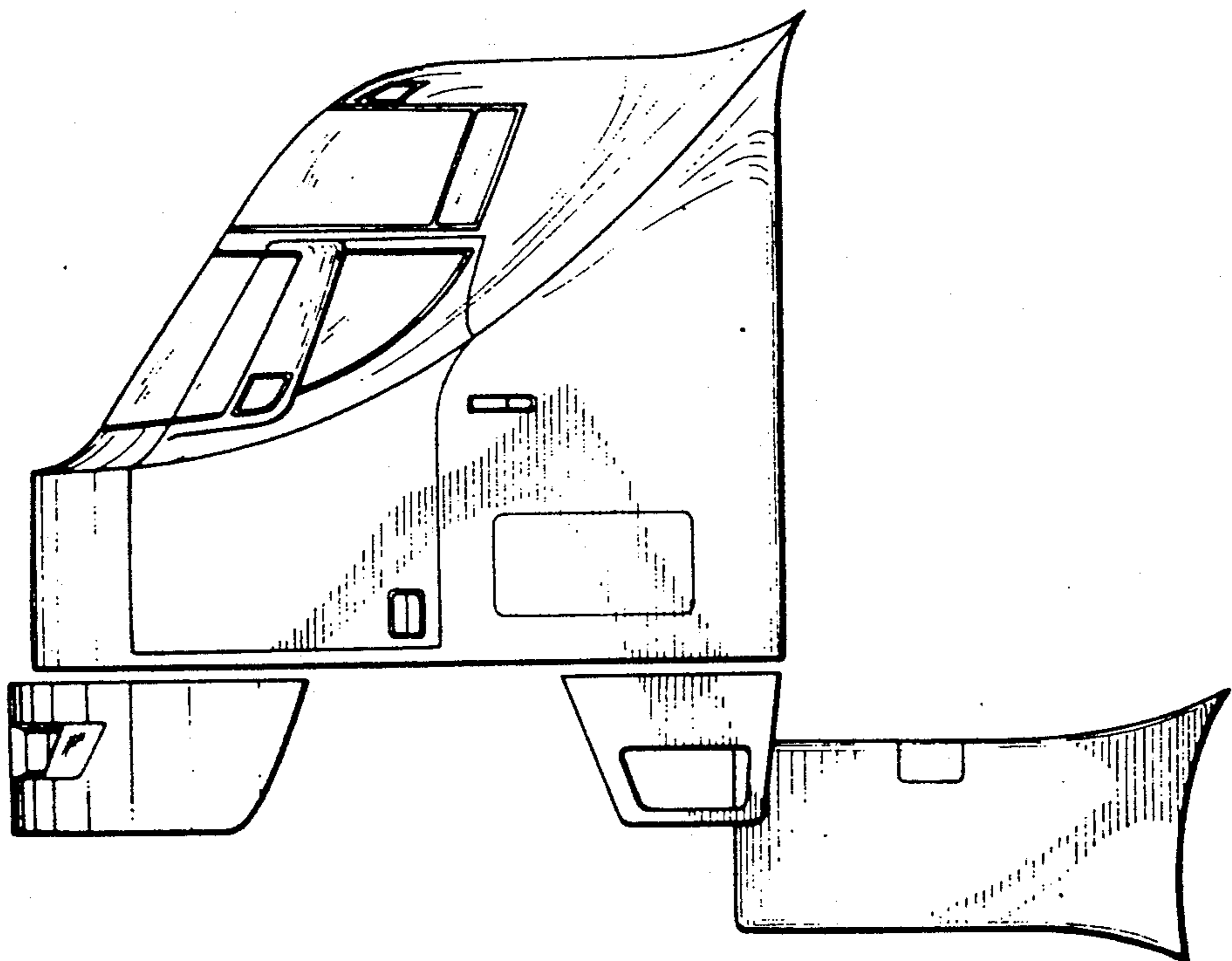

FIG. 4

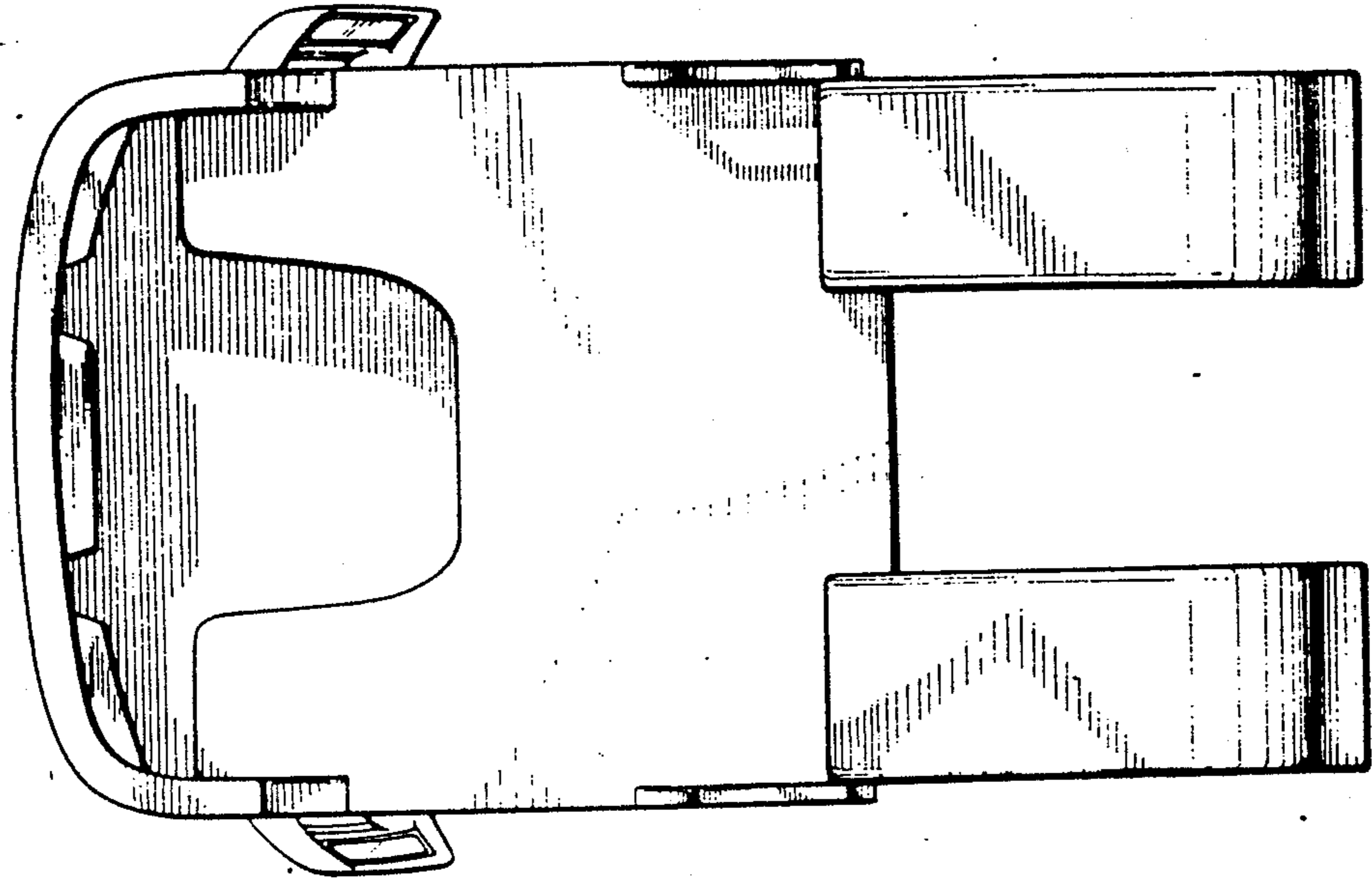

FIG. 5

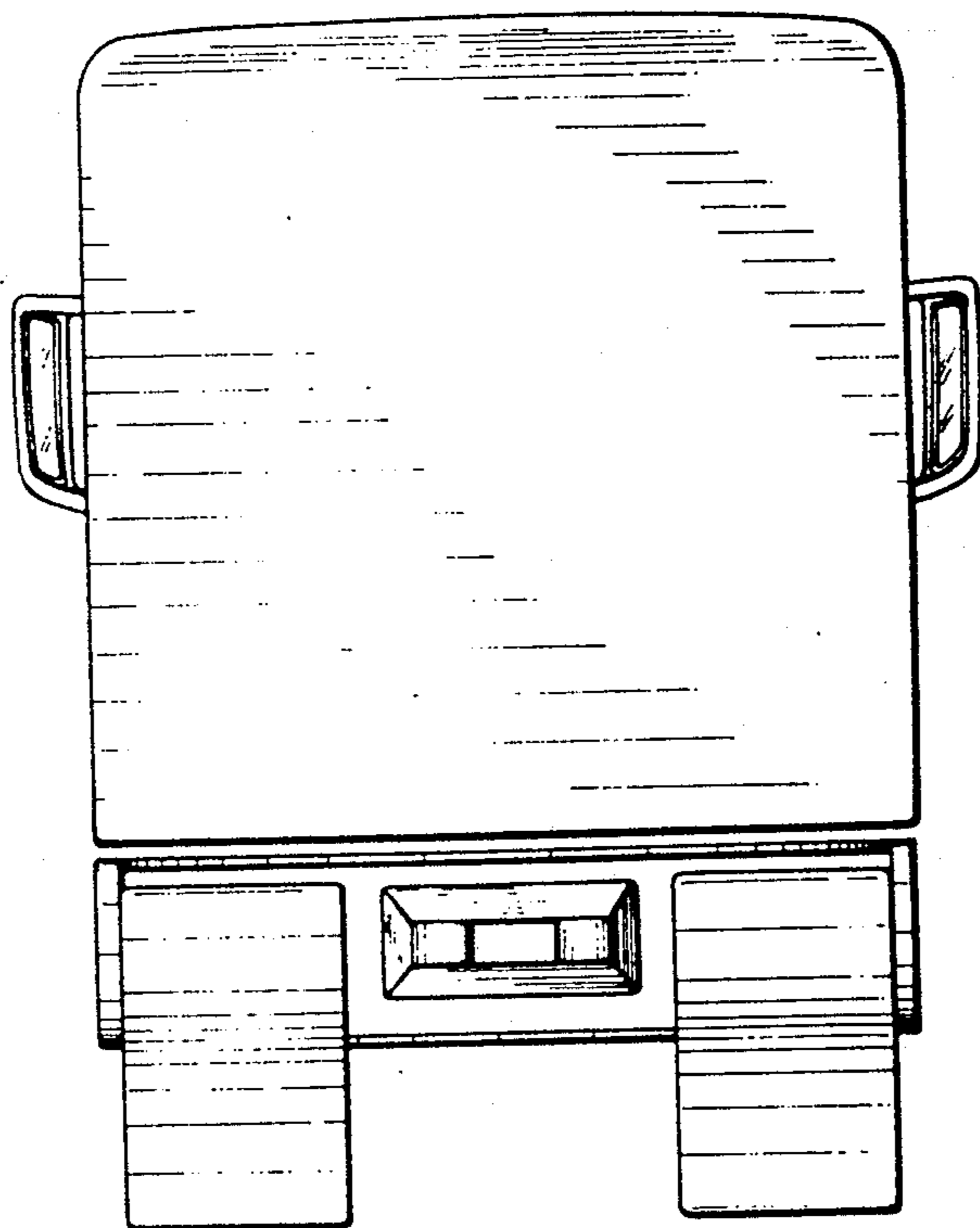

FIG. 6