

[54] CEMENT MIXER TRUCK

[76] Inventor: Frederick J. Silbernagel, R.R. 4, Huron, S. Dak. 57350

[**] Term: 14 Years

[21] Appl. No.: 664,600

[22] Filed: Oct. 25, 1984

[52] U.S. Cl. D12/95

[58] Field of Search D12/95; D15/19; 366/54

[56] References Cited

U.S. PATENT DOCUMENTS

- D. 249,665 9/1978 Silbernagel D12/95
- D. 271,875 12/1983 Silbernagel D15/19

OTHER PUBLICATIONS

Popular Science, 8/76, p. 67, Transit-Mix Truck, top right side of page.

Commercial Car Journal, 8/75, p. 14, Oshkosh B Front-End Mixer, bottom right side of page.

Primary Examiner—James M. Gandy
Attorney, Agent, or Firm—Kinney & Lange

[57] CLAIM

The ornamental design for a cement mixer truck, as shown and described.

DESCRIPTION

FIG. 1 is a top plan view of a cement mixer truck embodying my new design;

FIG. 2 is a side elevational view thereof;

FIG. 3 is a side elevational view thereof taken from an opposite side from FIG. 2;

FIG. 4 is a front elevational view thereof;

FIG. 5 is a rear elevational view thereof;

FIG. 6 is a side elevational view of a cement mixer truck

showing a second embodiment of my new design, the difference being in the length thereof using only one set of rear wheels and the omission of the discharge chute sections from one side thereof and the gas tank from the opposite side thereof, it being understood that the opposite side is substantially a mirror image thereof and that the top view, front view and rear view are substantially the same as the first embodiment;

FIG. 7 is a side elevational view of a cement mixer truck showing a third embodiment of my new design, the difference from the second embodiment being the addition of auxiliary wheels between the main front and rear wheels, it being understood that the opposite side is substantially a mirror image thereof, and that the top view, front and rear view, are substantially the same as those shown in the first embodiment;

FIG. 8 is a side elevational view of a cement mixer truck showing a fourth embodiment of my new design, the difference from the first embodiment being the addition of a single auxiliary axle between the front and rear wheels and the omission of the discharge chute sections from one side thereof and the gas tank from the opposite side thereof, it being understood that the opposite side is substantially a mirror image thereof, and that the top view, front view and rear view are substantially the same as that shown in the first embodiment; and

FIG. 9 is a side elevational view of a cement mixer truck showing a fifth embodiment of my new design, the difference from the first embodiment being the addition of two auxiliary axles between the front and rear wheels and the omission of the discharge chute sections from one side thereof and the gas tank from the opposite side thereof, it being understood that the opposite side is substantially a mirror image thereof, and that the top view, front view, and rear view are substantially the same as those shown in the first embodiment.

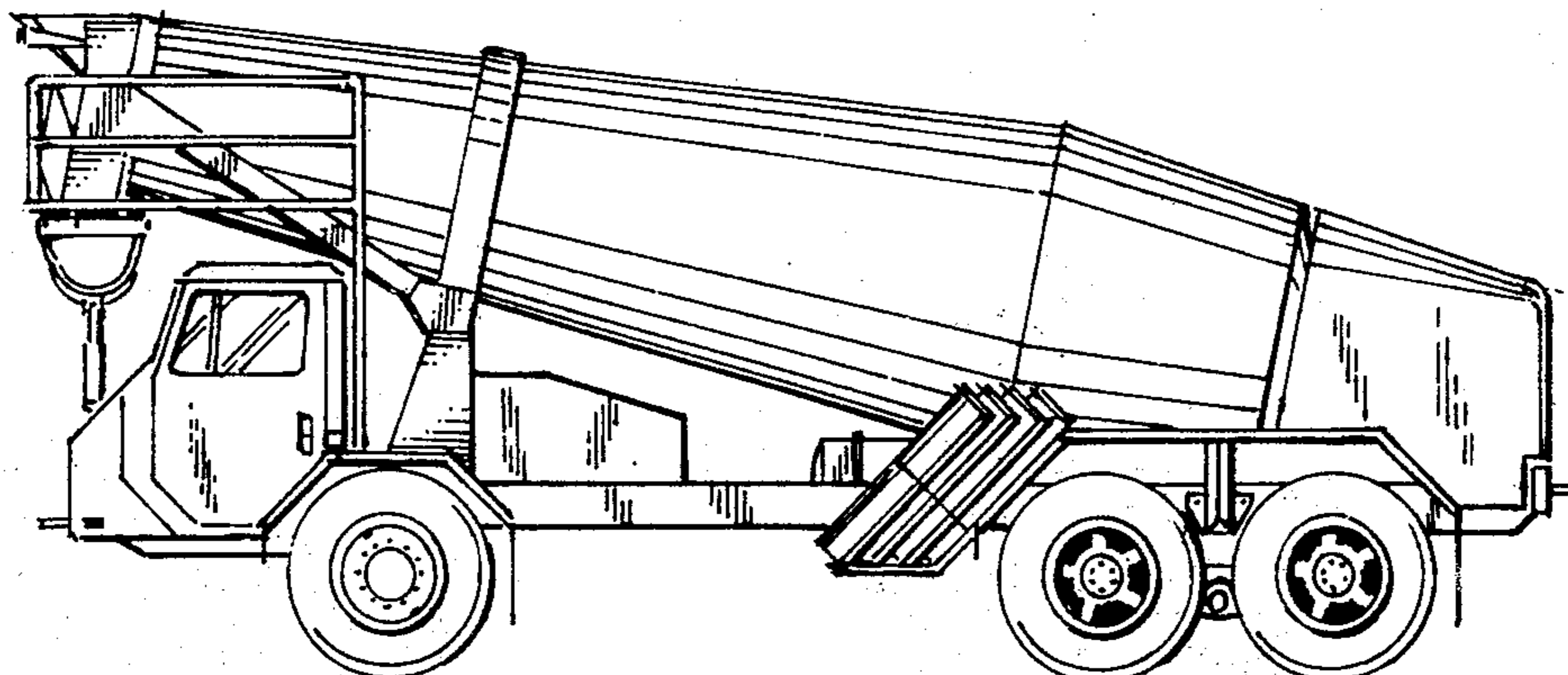

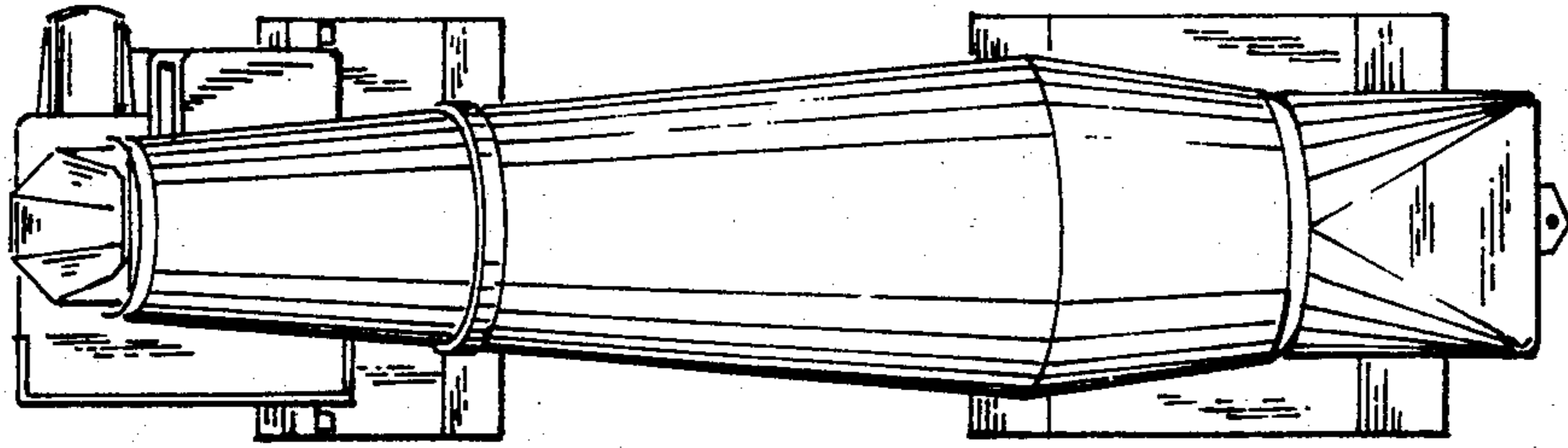

FIG. 1

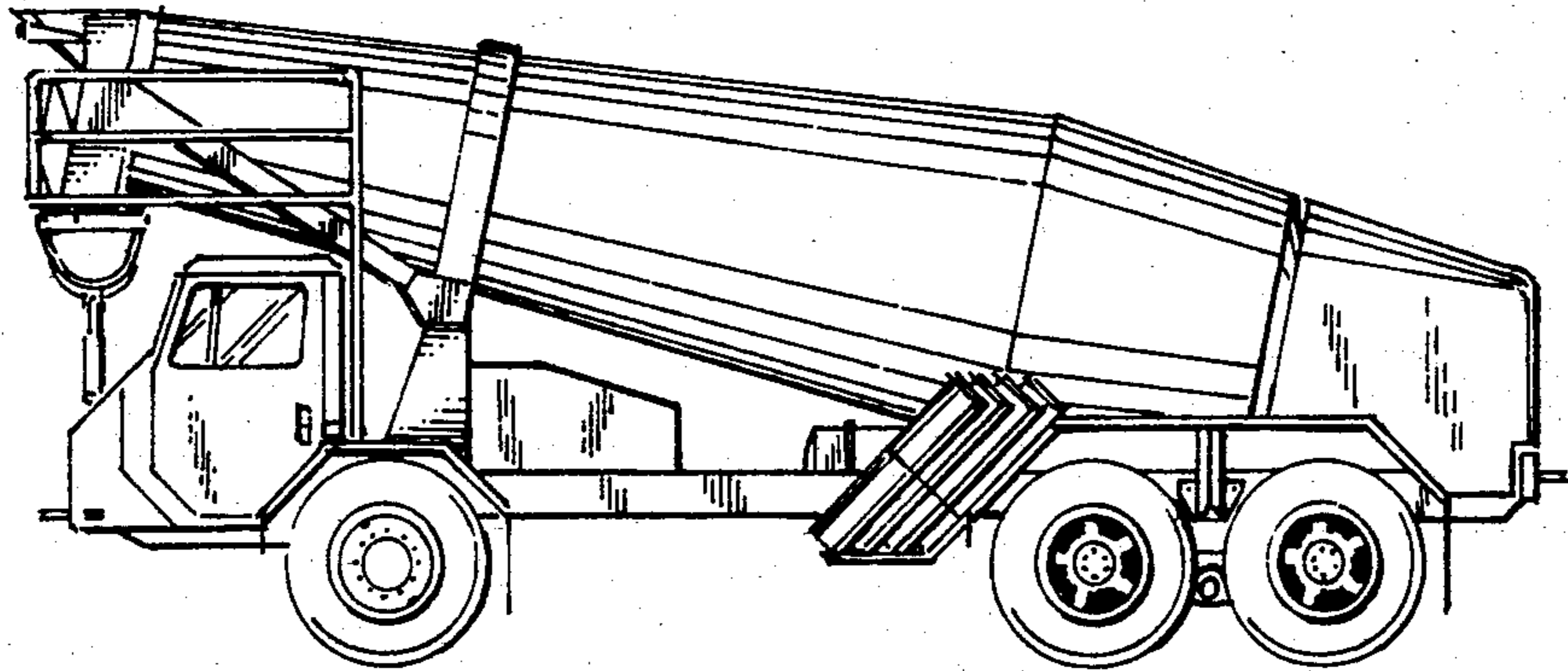

FIG. 2

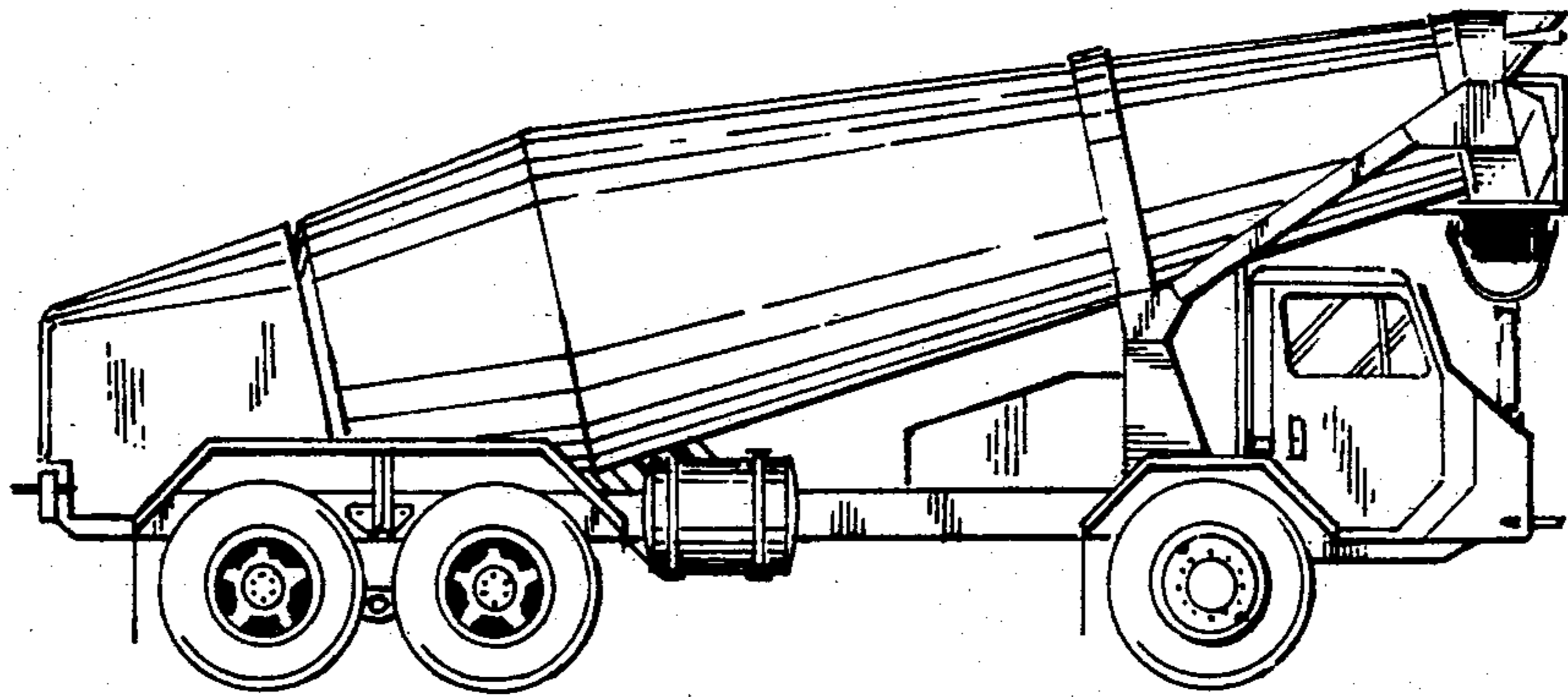

FIG. 3

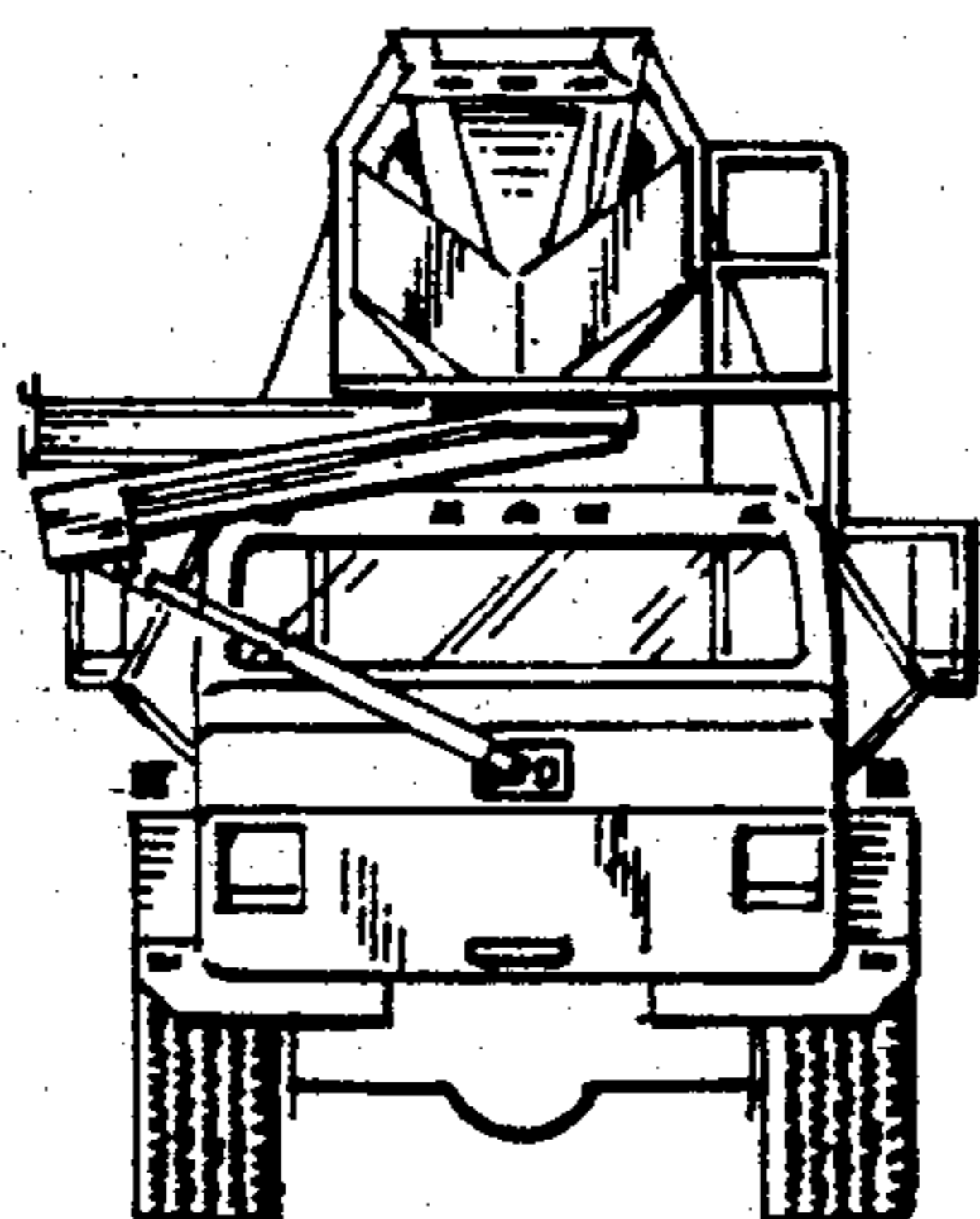

FIG. 4

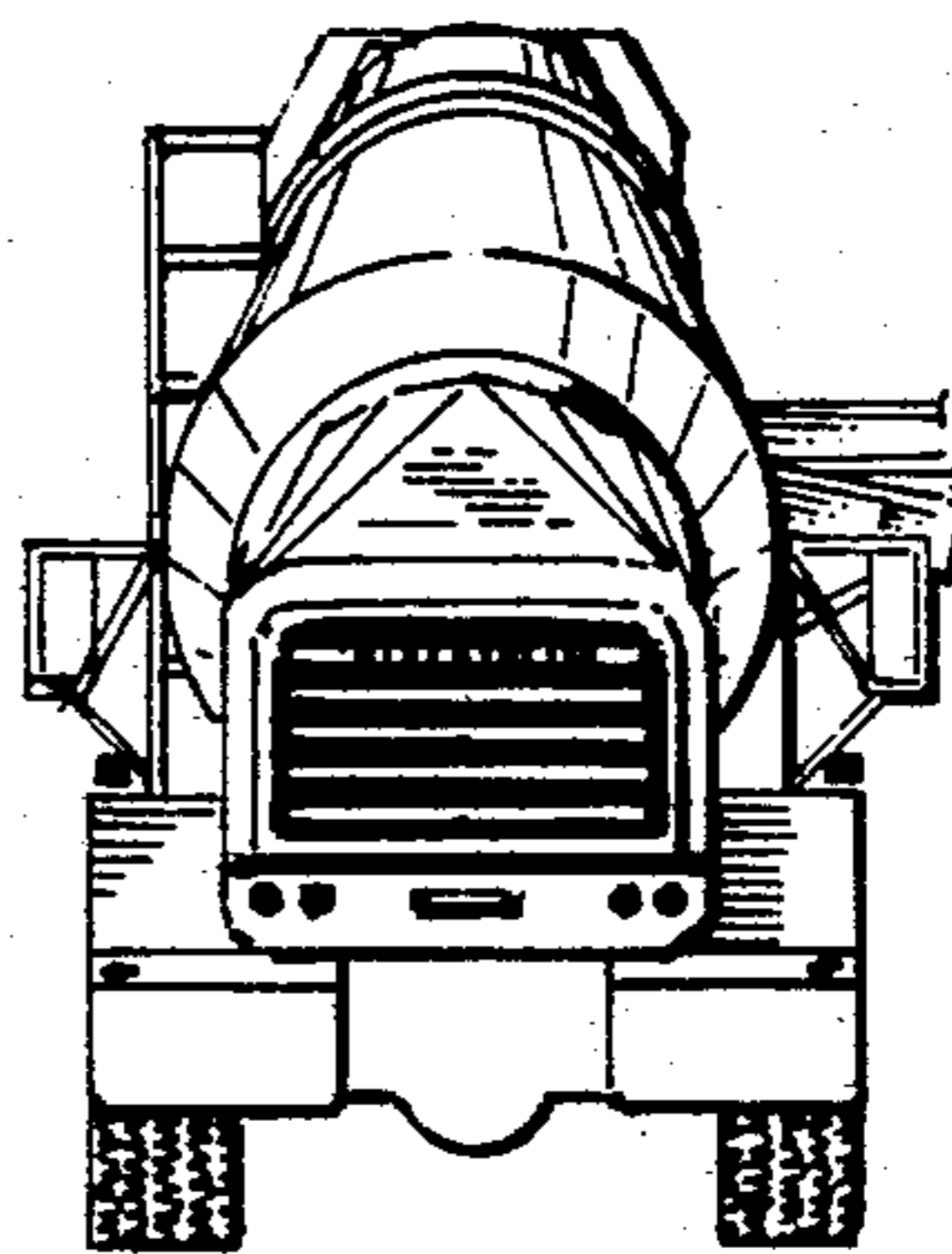

FIG. 5

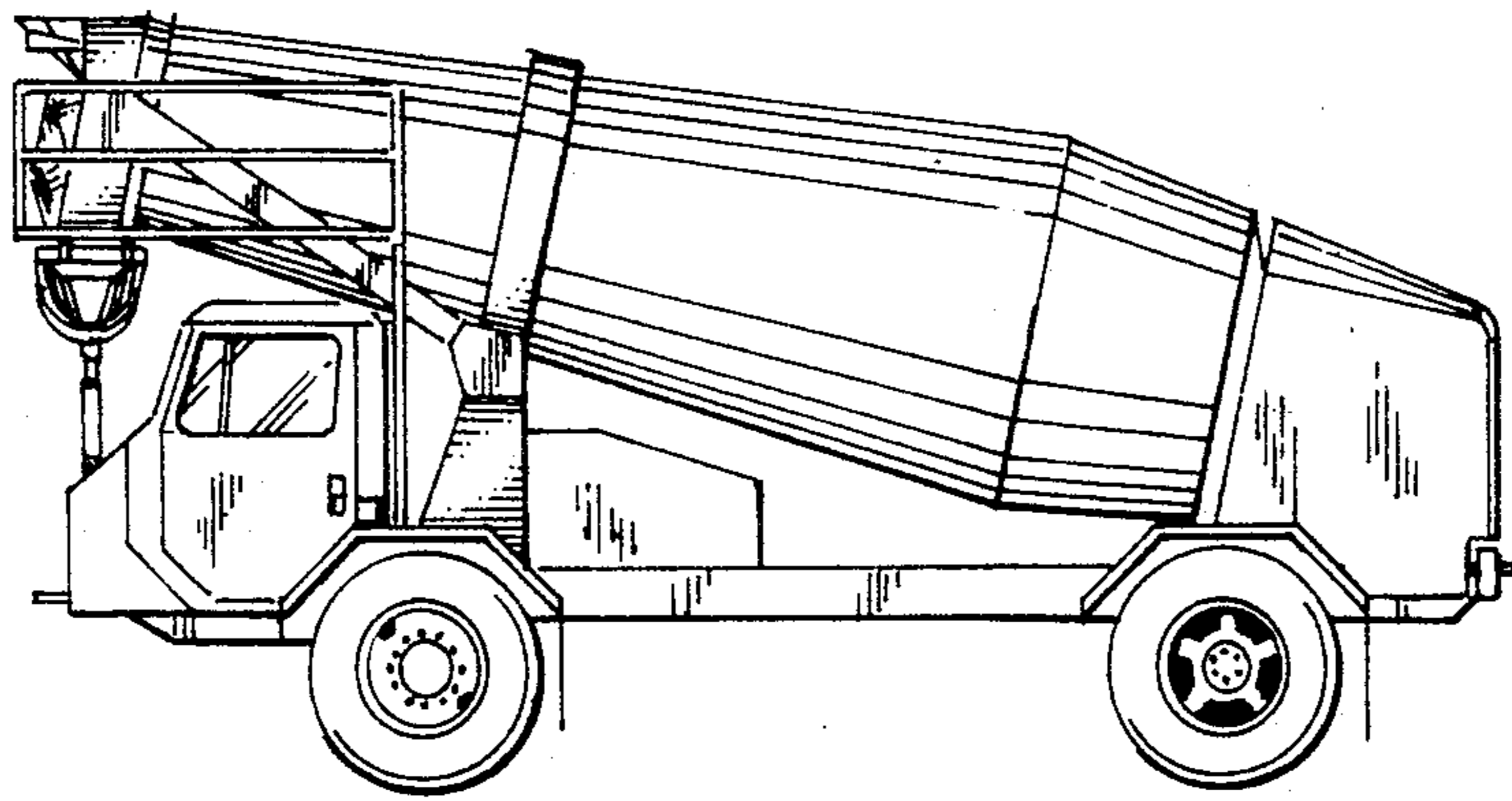

FIG. 6

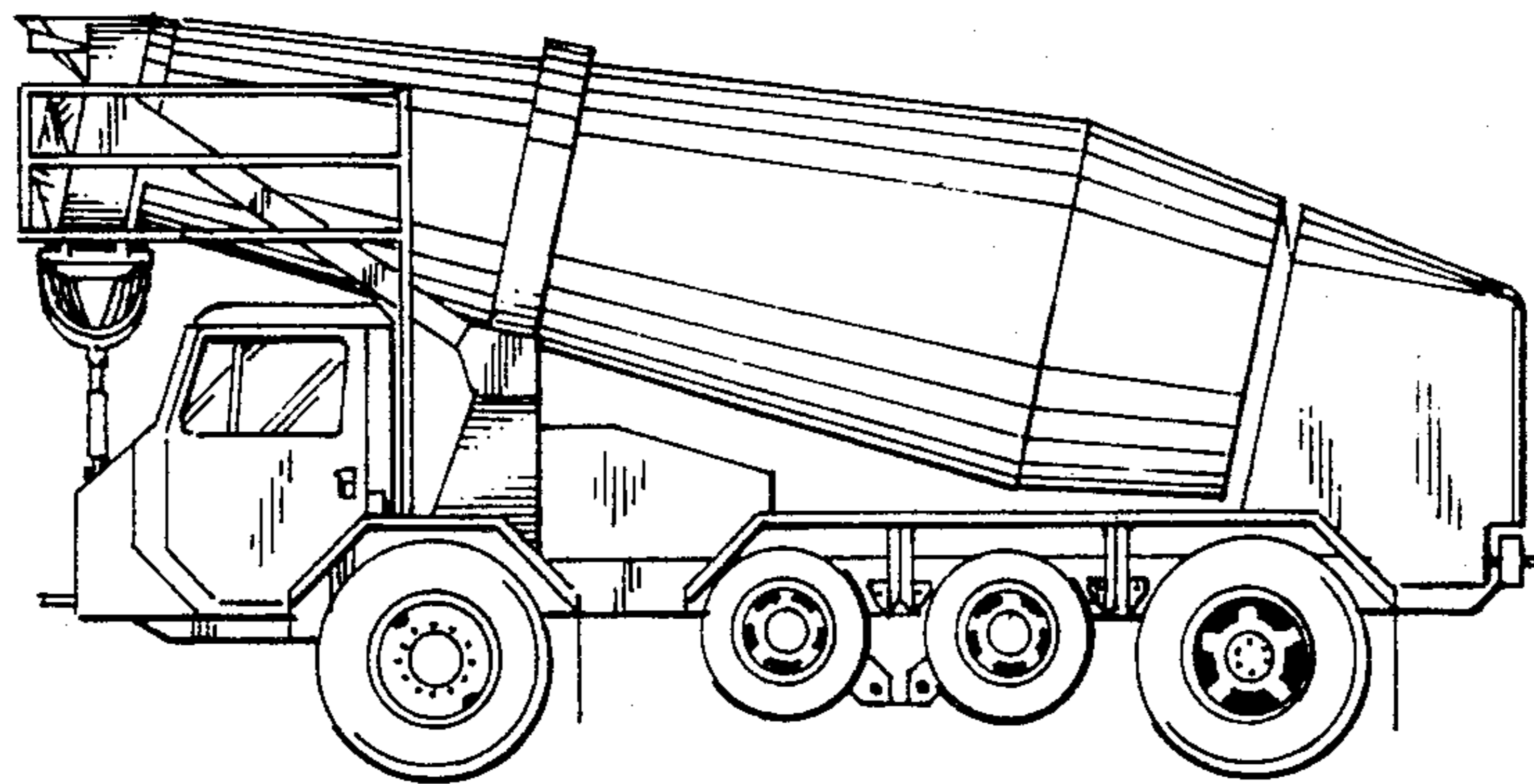

FIG. 7

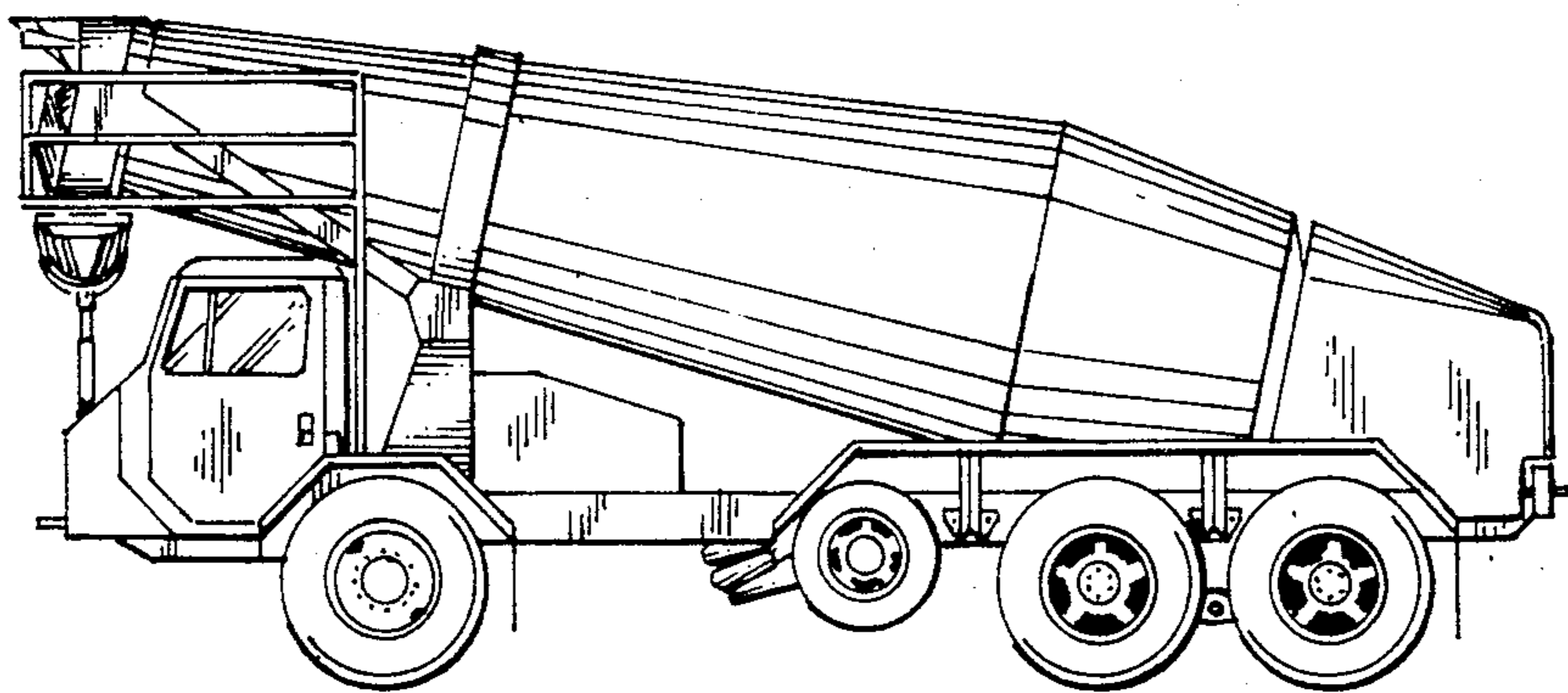

FIG. 8

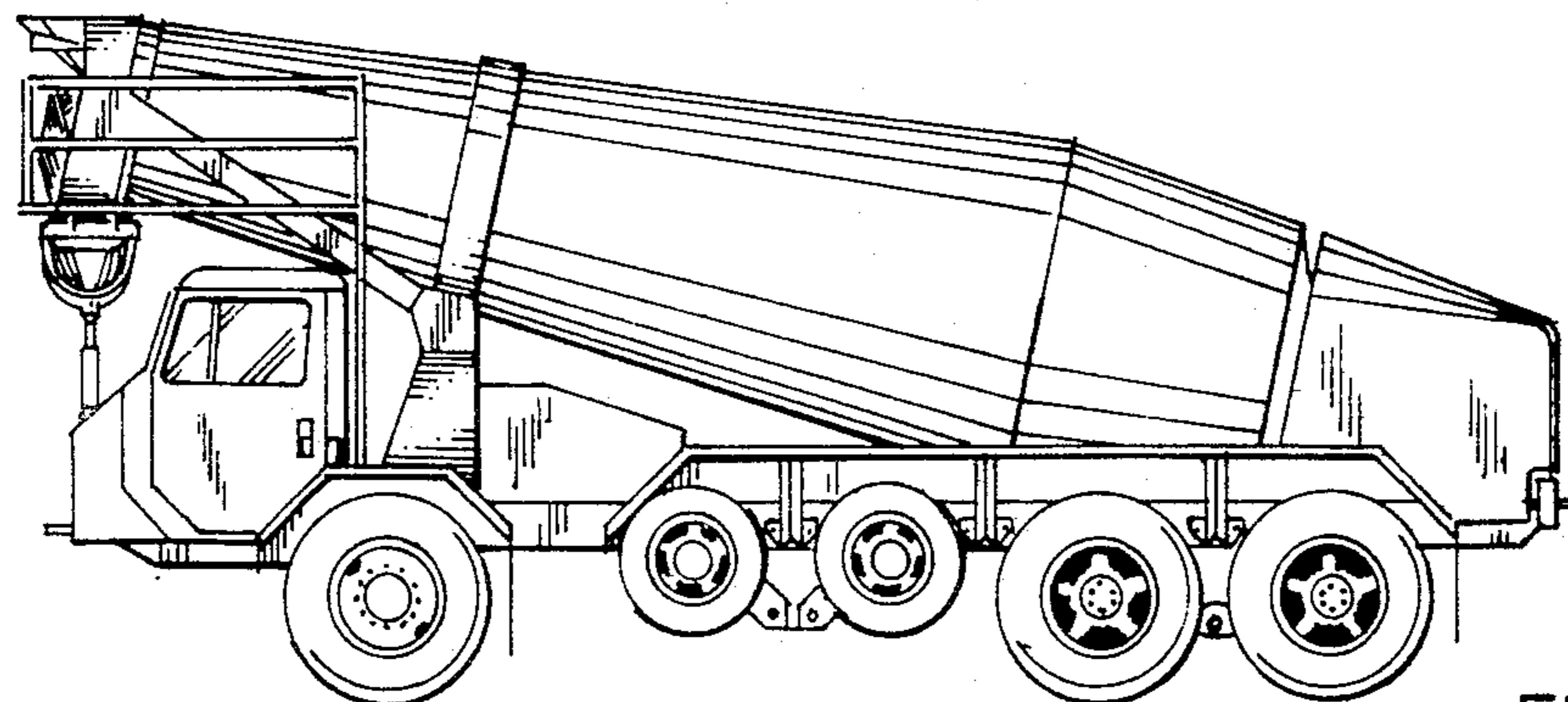

FIG. 9