

[54] AIR DRIVEN LABELLER

[75] Inventor: D. Dwain Conley, Kingston, Mass.

[73] Assignee: Esselte Pendaflex Corporation,
Garden City, N.Y.

[**] Term: 14 Years

[21] Appl. No.: 645,016

[22] Filed: Aug. 28, 1984

[52] U.S. Cl. D18/19

[58] Field of Search D18/14, 19; 101/288;
156/384, DIG. 48, DIG. 49

[56] References Cited

U.S. PATENT DOCUMENTS

D. 265,568	7/1982	Kalifa	D18/19
D. 268,595	4/1983	Beers	D18/19
4,470,864	9/1984	Haden, Jr. et al.	156/384

Primary Examiner—Louis S. Zarfes
Attorney, Agent, or Firm—Darby & Darby

[57] CLAIM

The ornamental design for an air driven labeller, as shown and described.

DESCRIPTION

FIG. 1 is a perspective view of an air driven labeller showing my new design;
FIG. 2 is a right side elevational view;
FIG. 3 is a left side elevational view;
FIG. 4 is a rear elevational view;
FIG. 5 is a top plan view;
FIG. 6 is a bottom plan view; and
FIG. 7 is a front elevational view.

The broken line showing of a pneumatic conduit is for illustrative purposes only and forms no part of the claimed design.

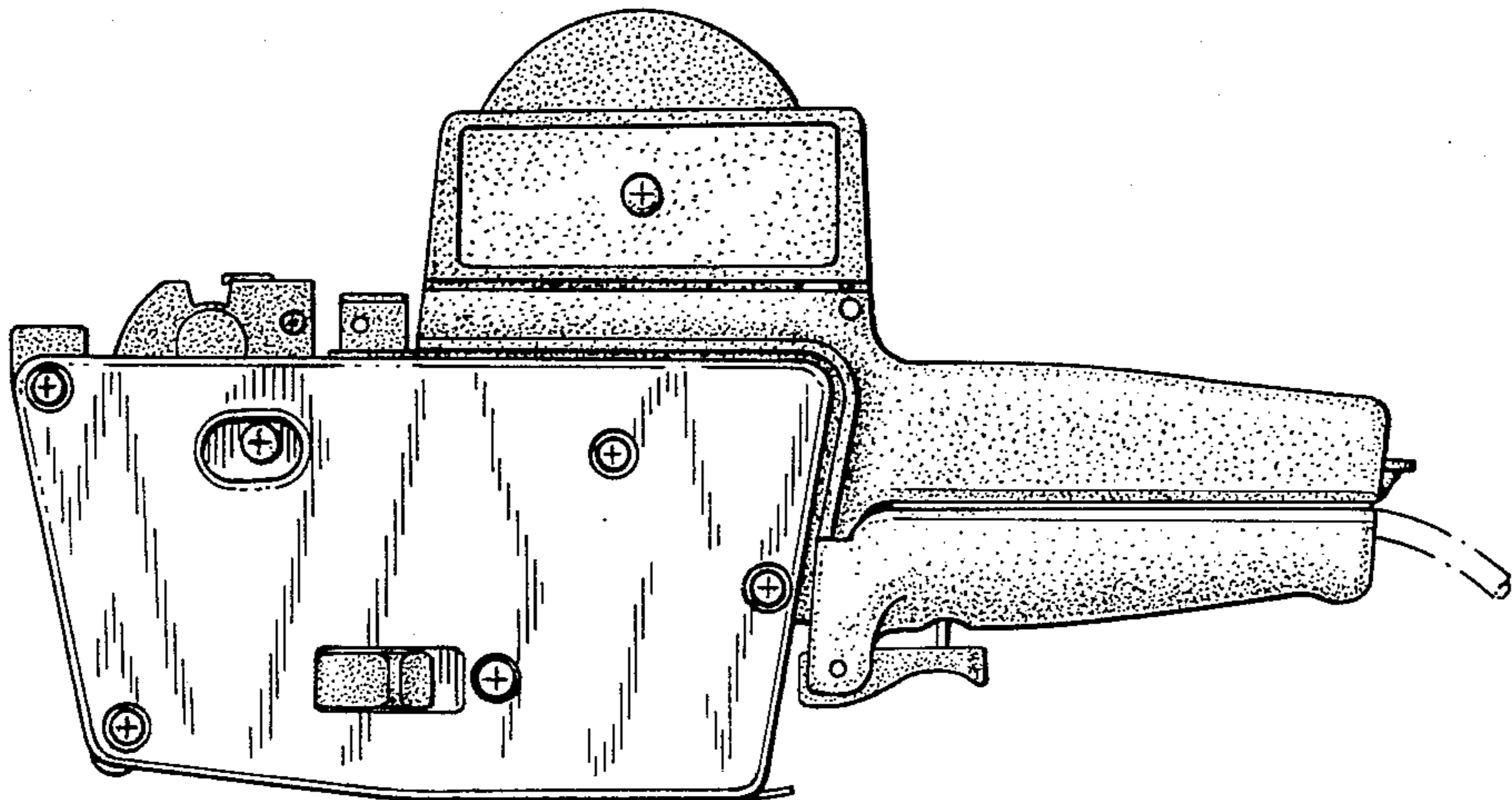

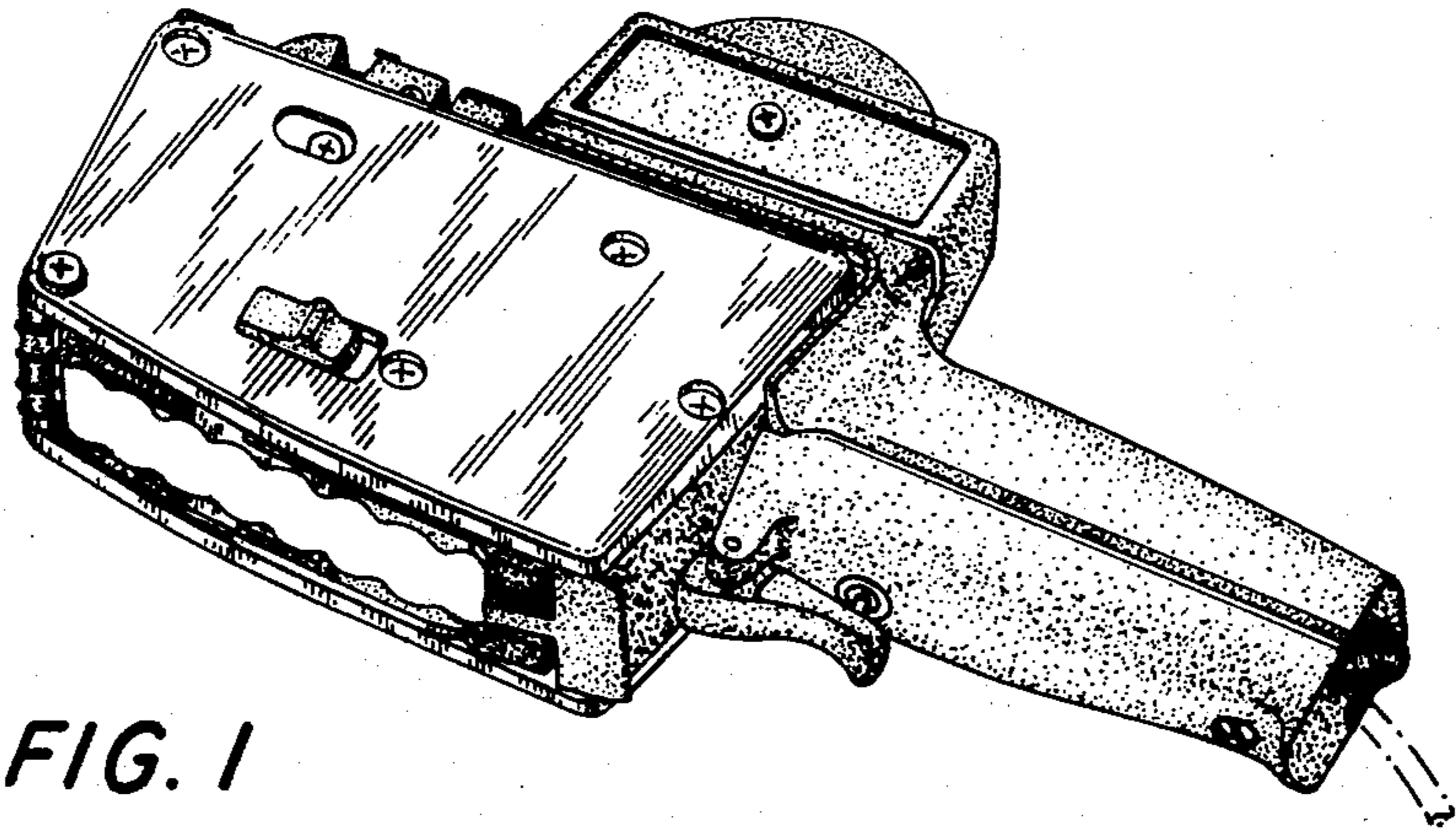

FIG. 1

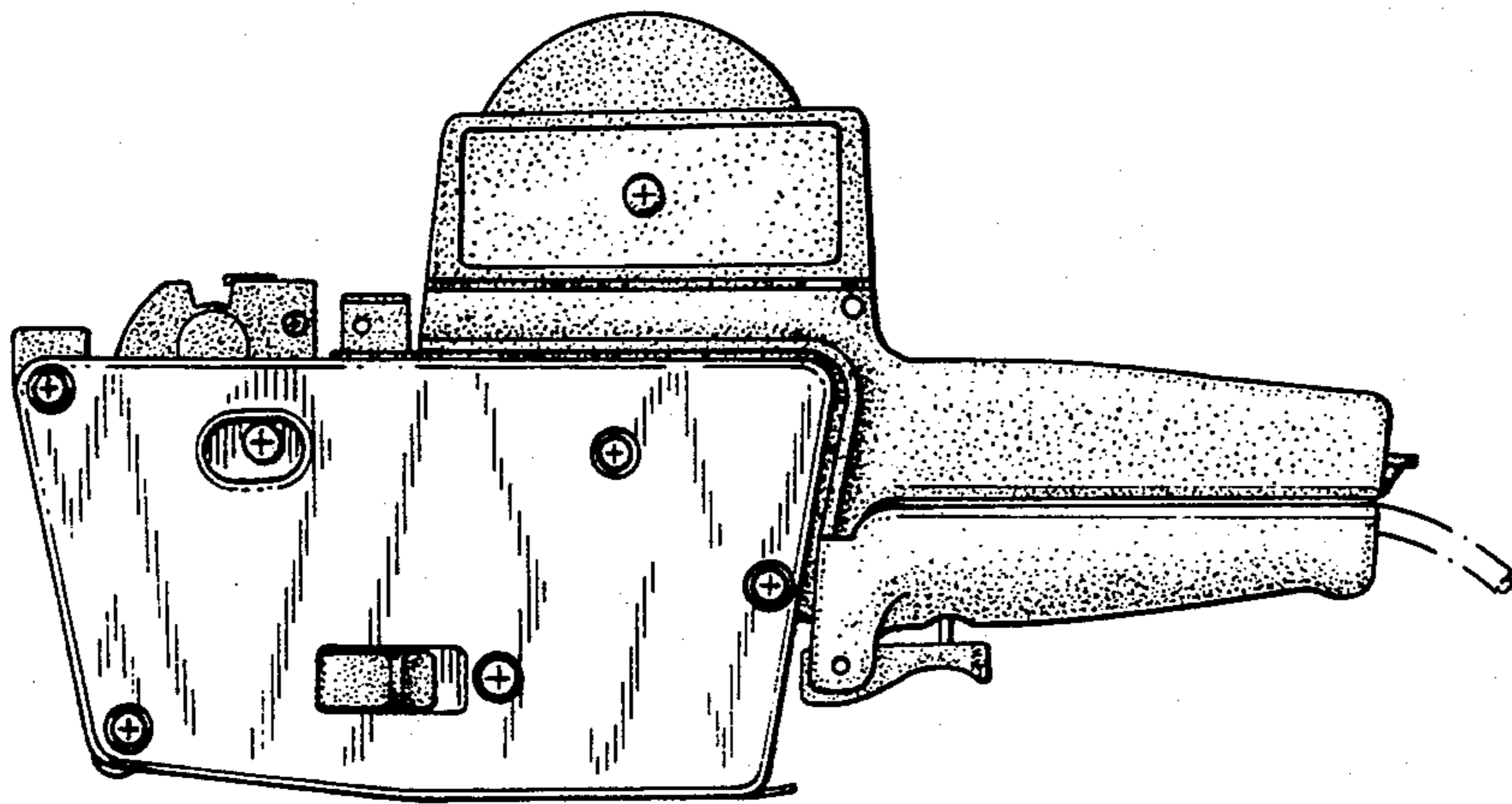

FIG. 2

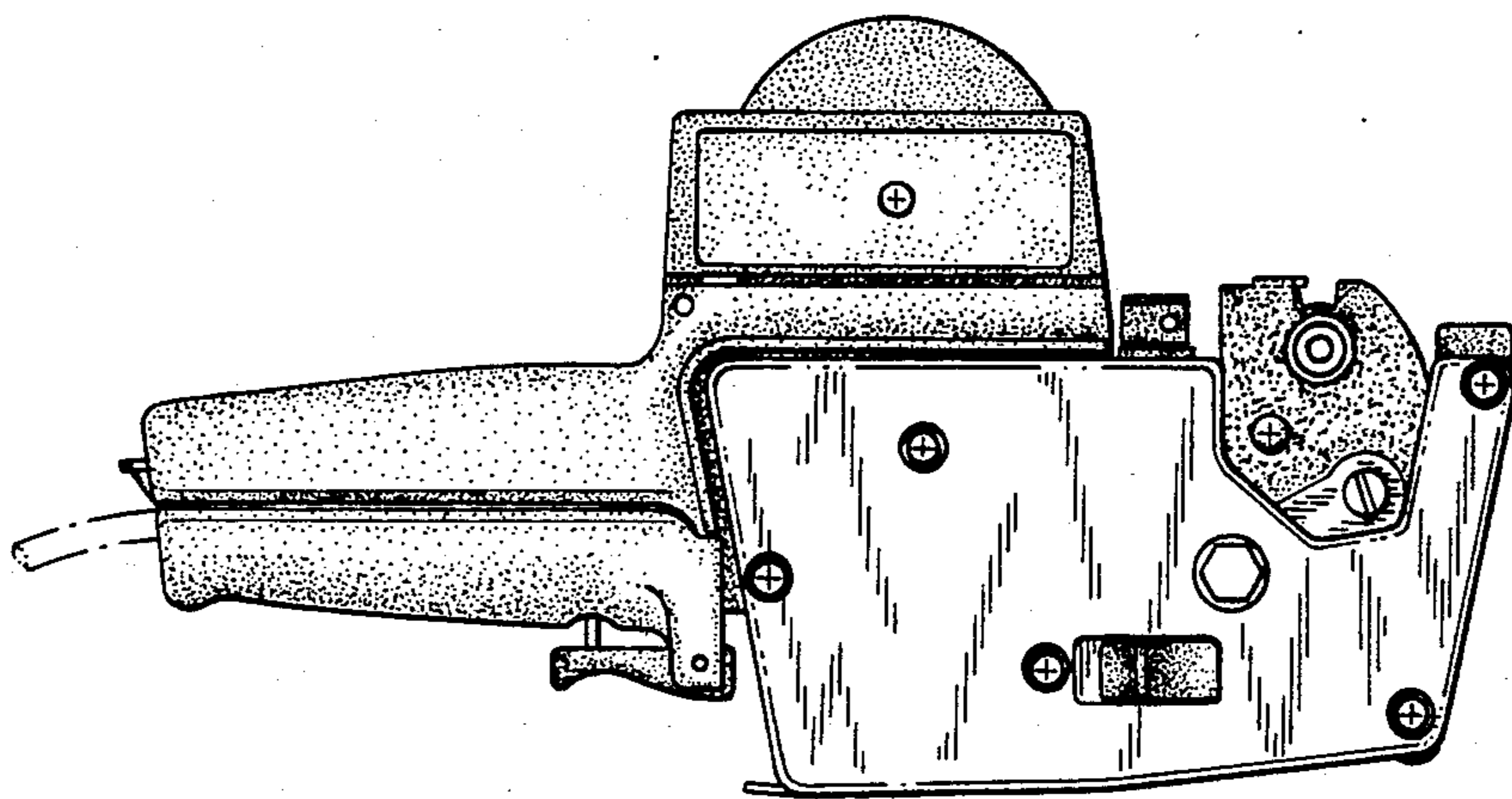

FIG. 3

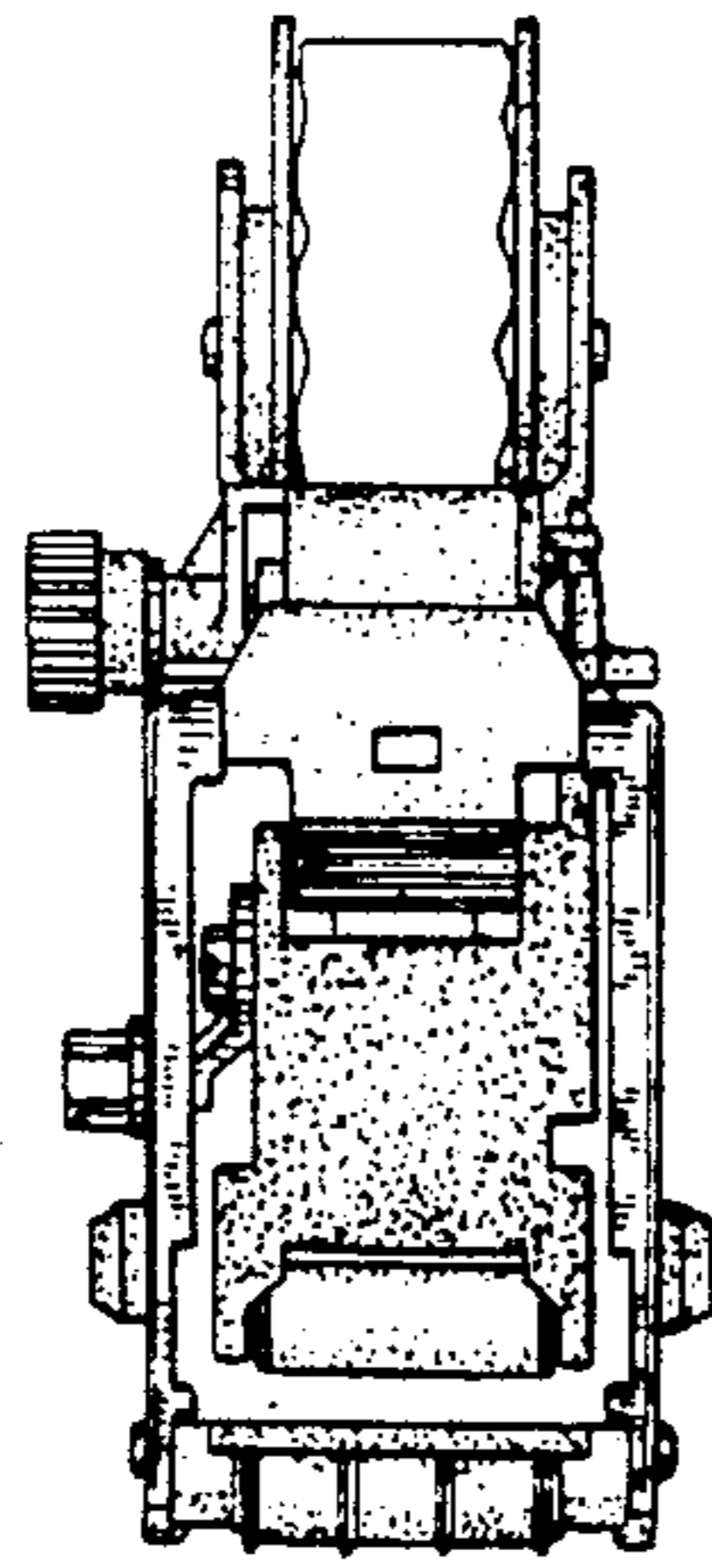

FIG. 7

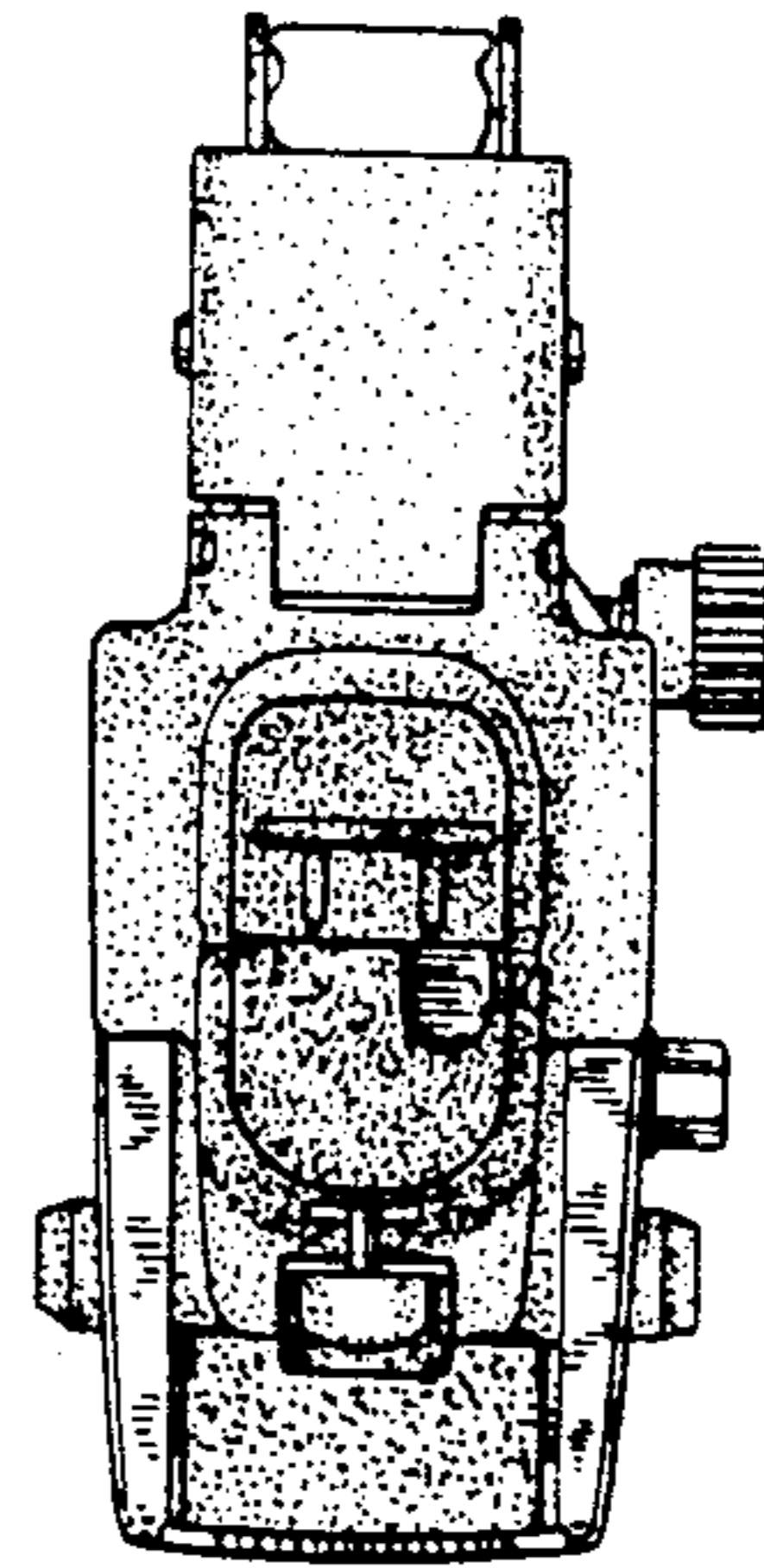

FIG. 4

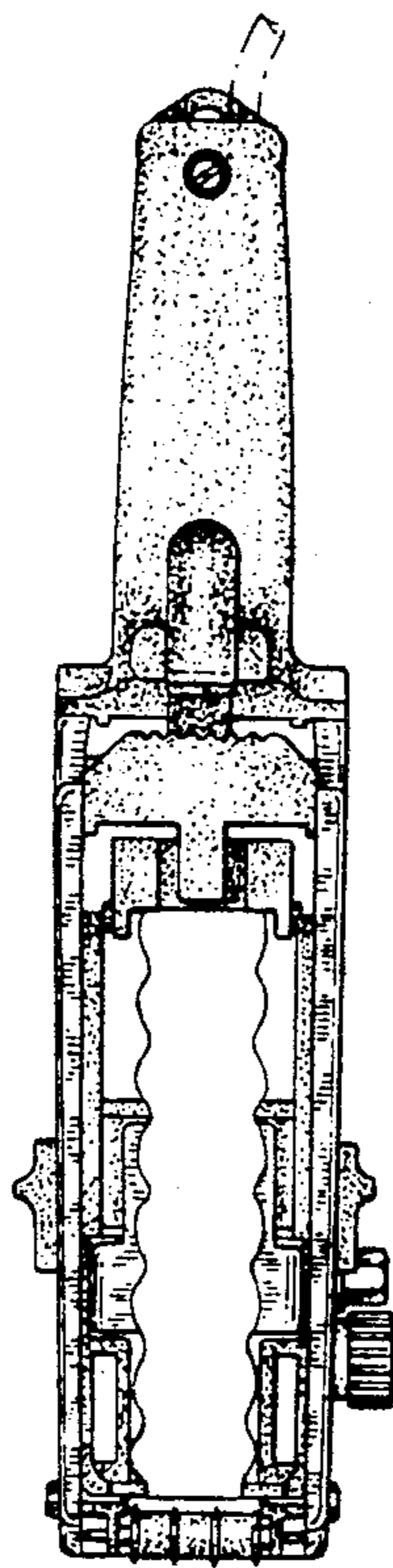

FIG. 6

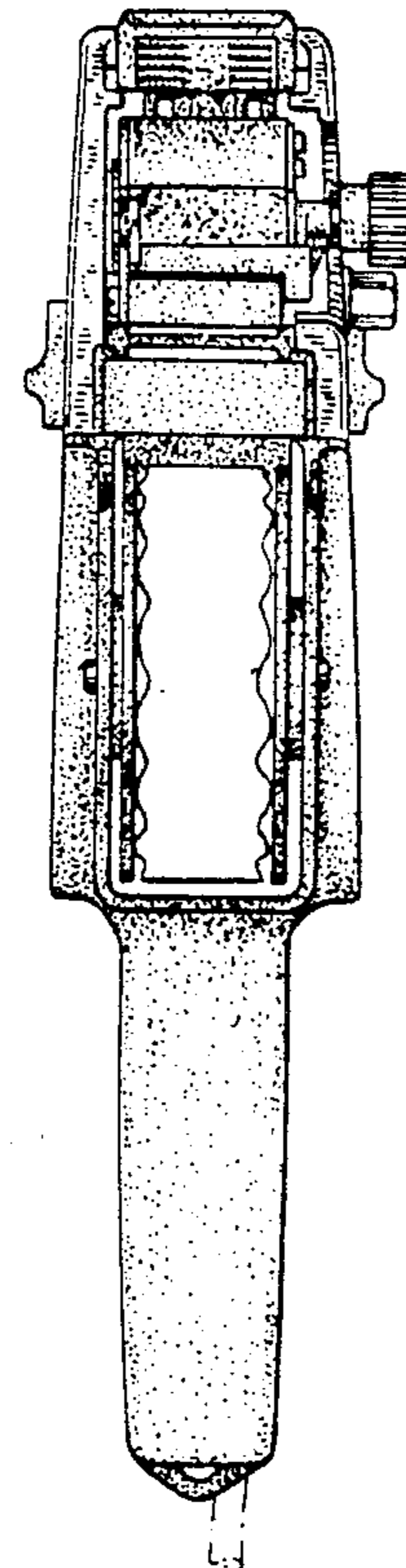

FIG. 5