

[54] TOY VEHICLE

[75] Inventors: Wayne Beiser; Howard N. Bollinger; Robert E. Cordrey; Charles E. Ligon; David A. Myers; Walter E. Stroud, all of Cincinnati, Ohio; W. Grey Williams, Covington; Earl M. Wood, Jr., Newport, both of Ky.

[73] Assignee: Kenner Parker Toys, Inc., Beverly, Mass.

[**] Term: 14 Years

[21] Appl. No.: 698,964

[22] Filed: Feb. 6, 1985

[52] U.S. Cl. D21/136

[58] Field of Search D21/128, 134, 135, 136, D21/137, 139, 140; D12/86; 446/465, 466, 487

[56] References Cited

U.S. PATENT DOCUMENTS

- D. 222,879 1/1972 Wilfert et al. D12/92
- D. 233,512 11/1974 Love et al. D12/92
- D. 266,779 11/1982 Appel et al. D21/137
- D. 281,087 10/1985 Ohno D21/136

Primary Examiner—Charles A. Rademaker
Attorney, Agent, or Firm—L. MeRoy Lillehaugen; Gene O. Enockson

[57] CLAIM

The ornamental design for a toy vehicle, substantially as shown and described.

DESCRIPTION

FIG. 1 is a side elevational view of a toy vehicle showing our new design, the side opposite being substantially a mirror image thereof;
 FIG. 2 is a top plan view thereof;
 FIG. 3 is a bottom plan view thereof;
 FIG. 4 is a front elevational view thereof;
 FIG. 5 is a rear elevational view thereof; and
 FIG. 6 is a perspective view of the toy vehicle which shows the vehicle in a slightly different condition.

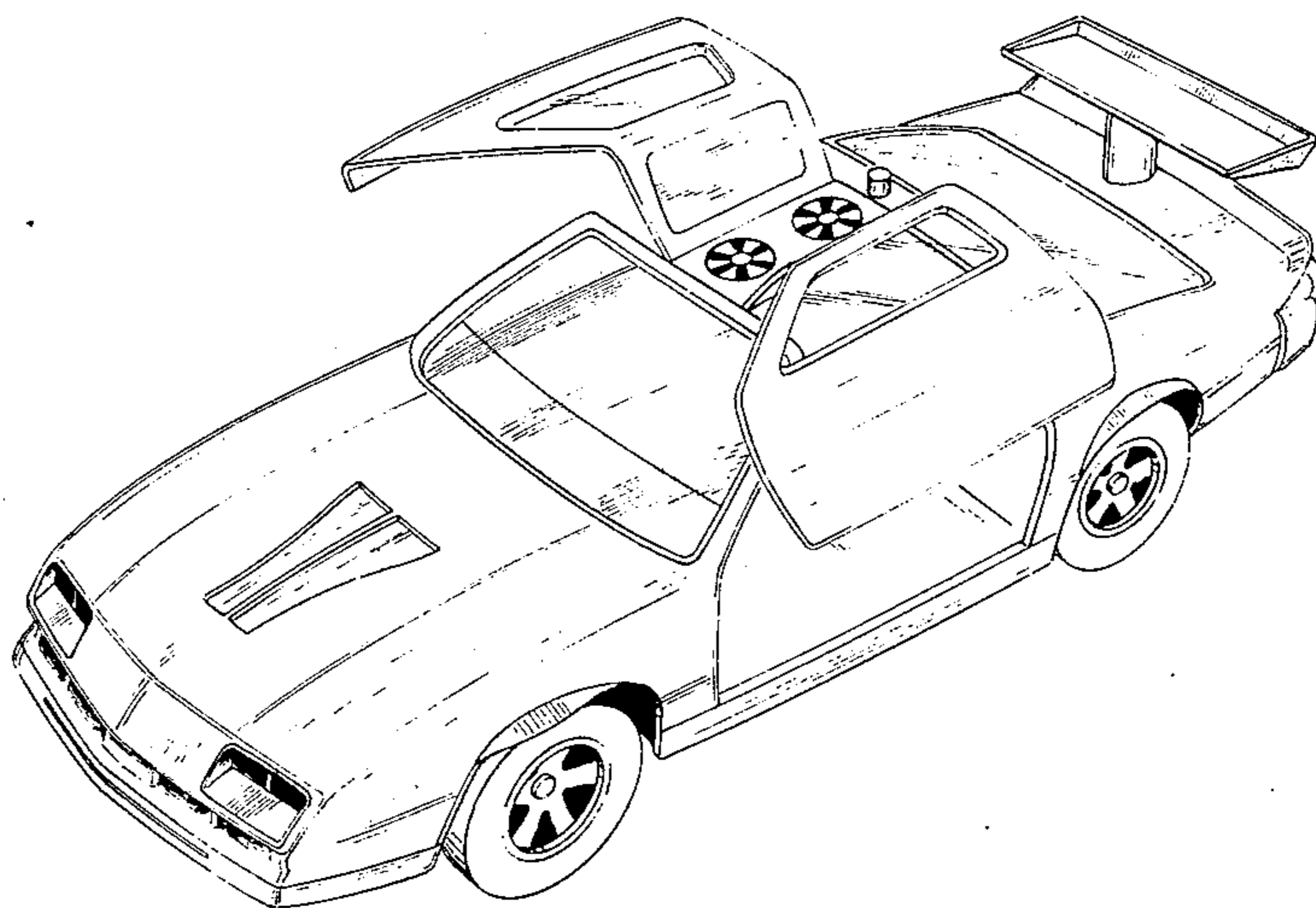

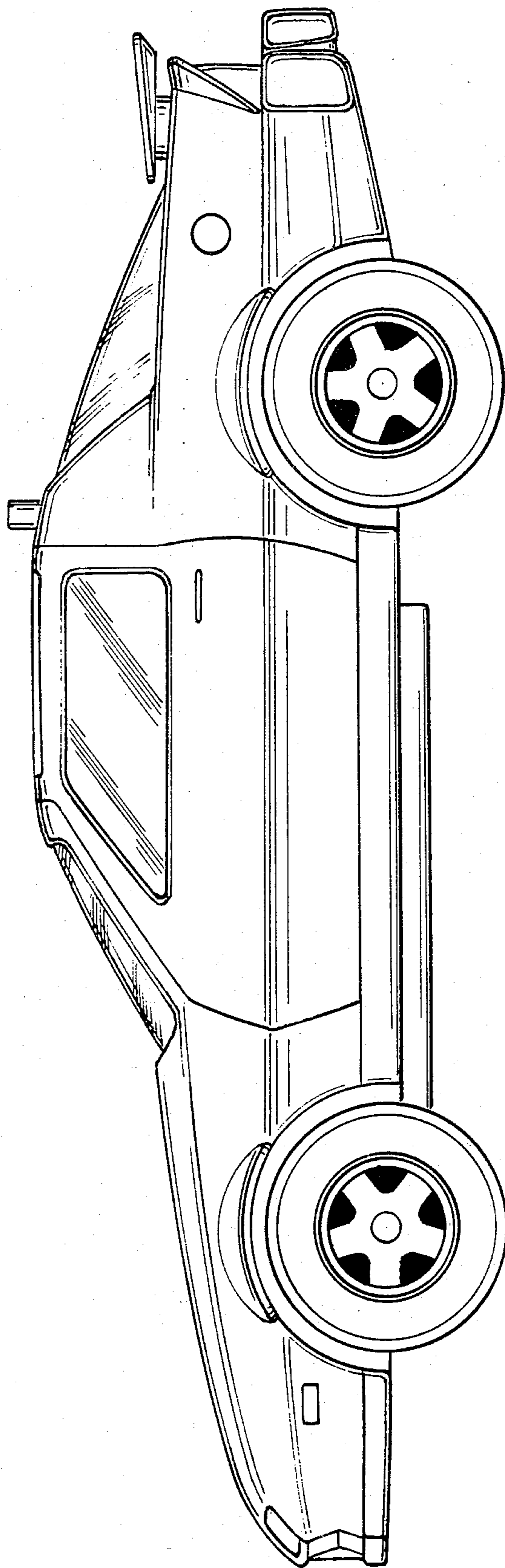

FIG. 1

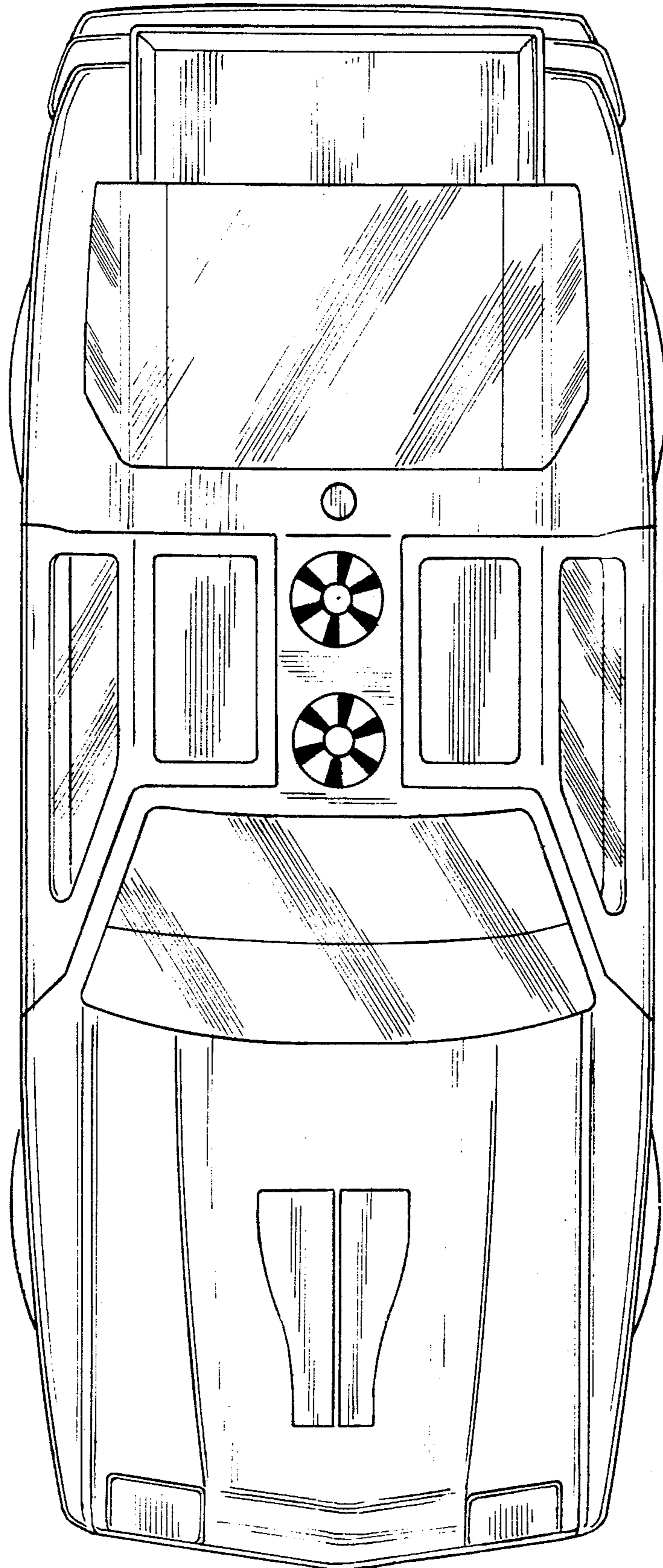

FIG. 2

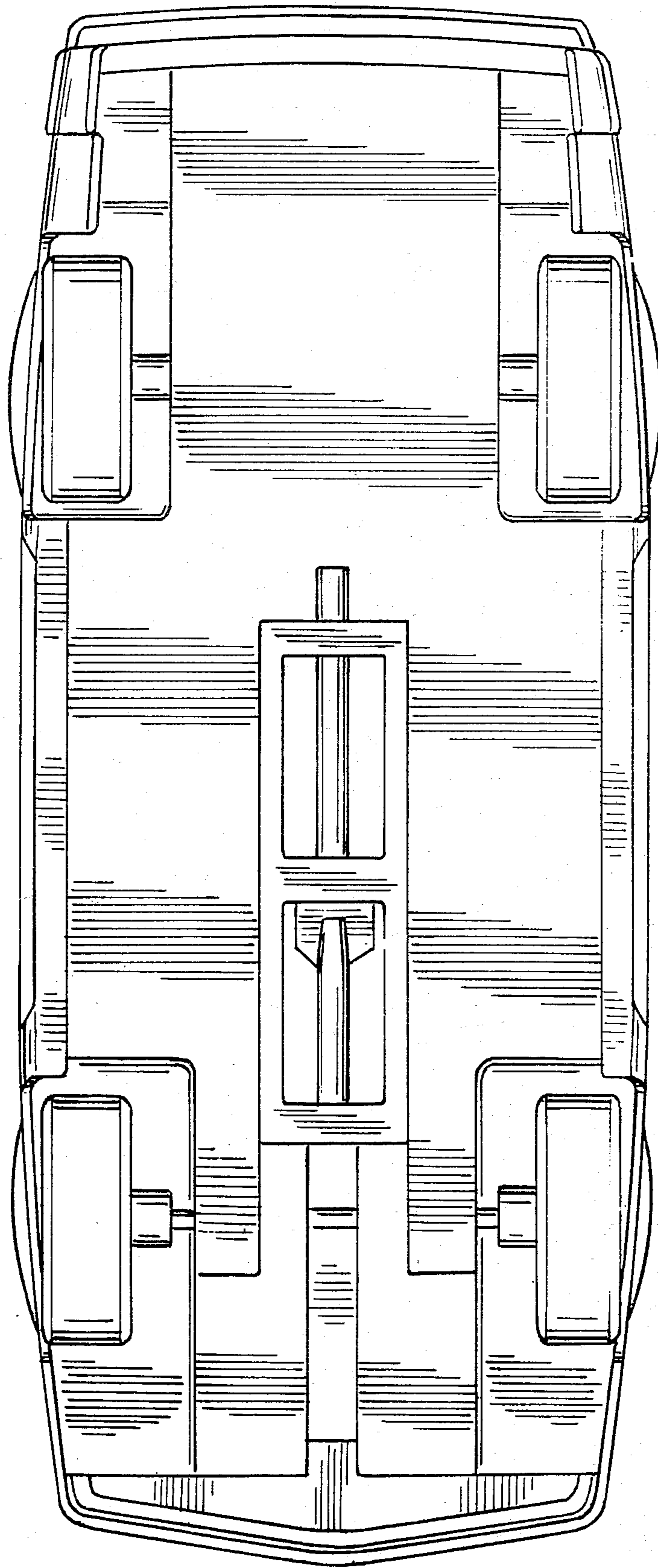

FIG. 3

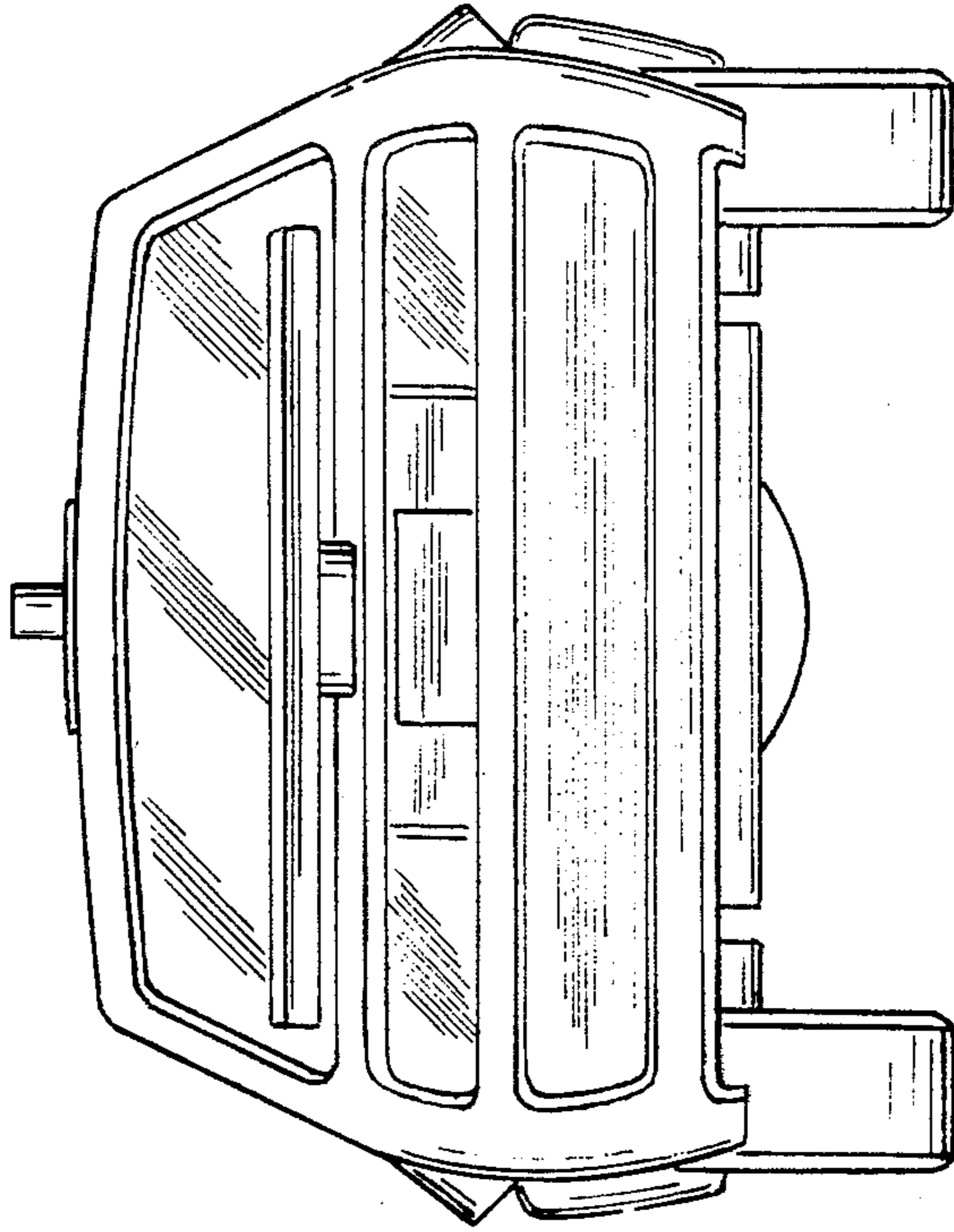

FIG. 5

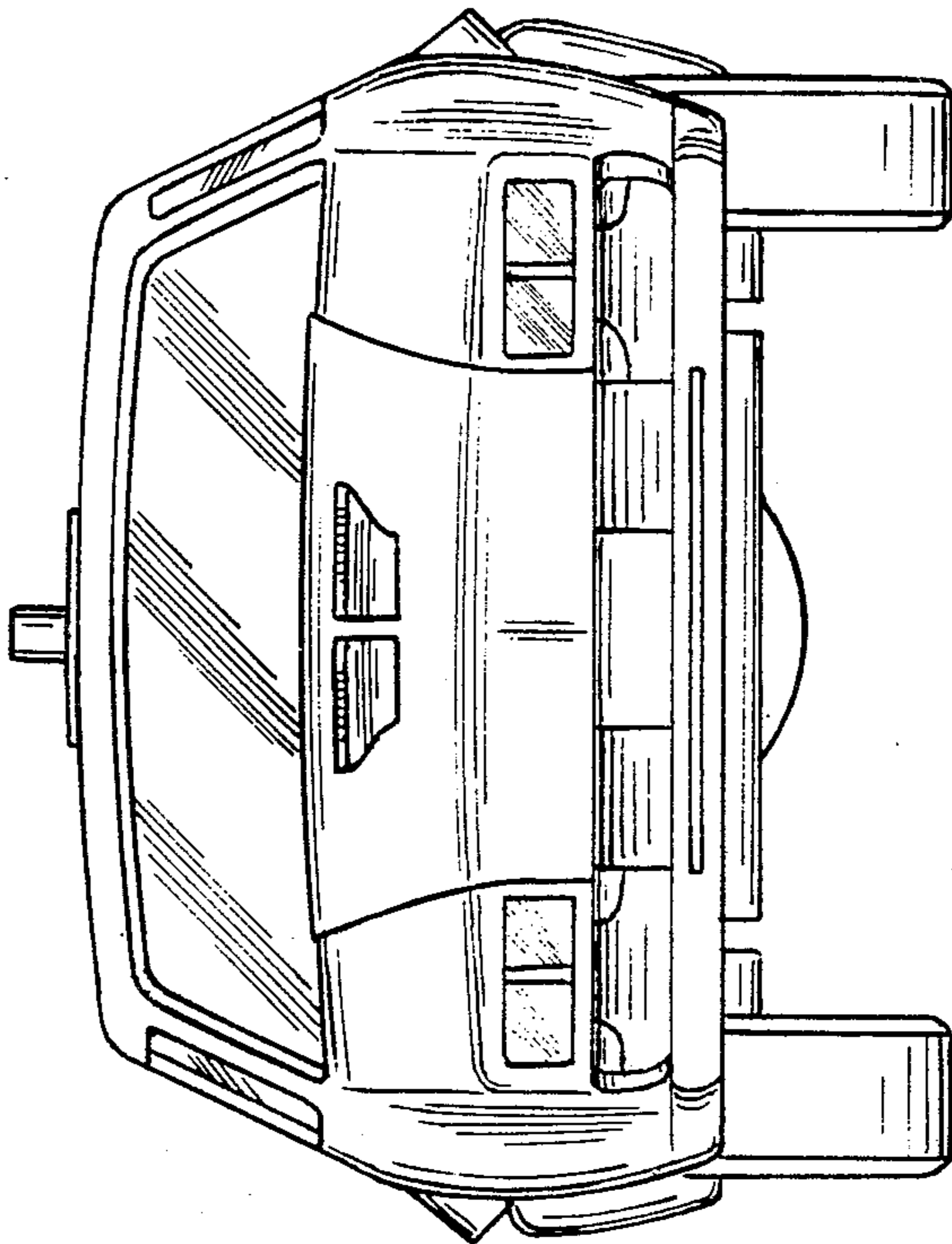

FIG. 4

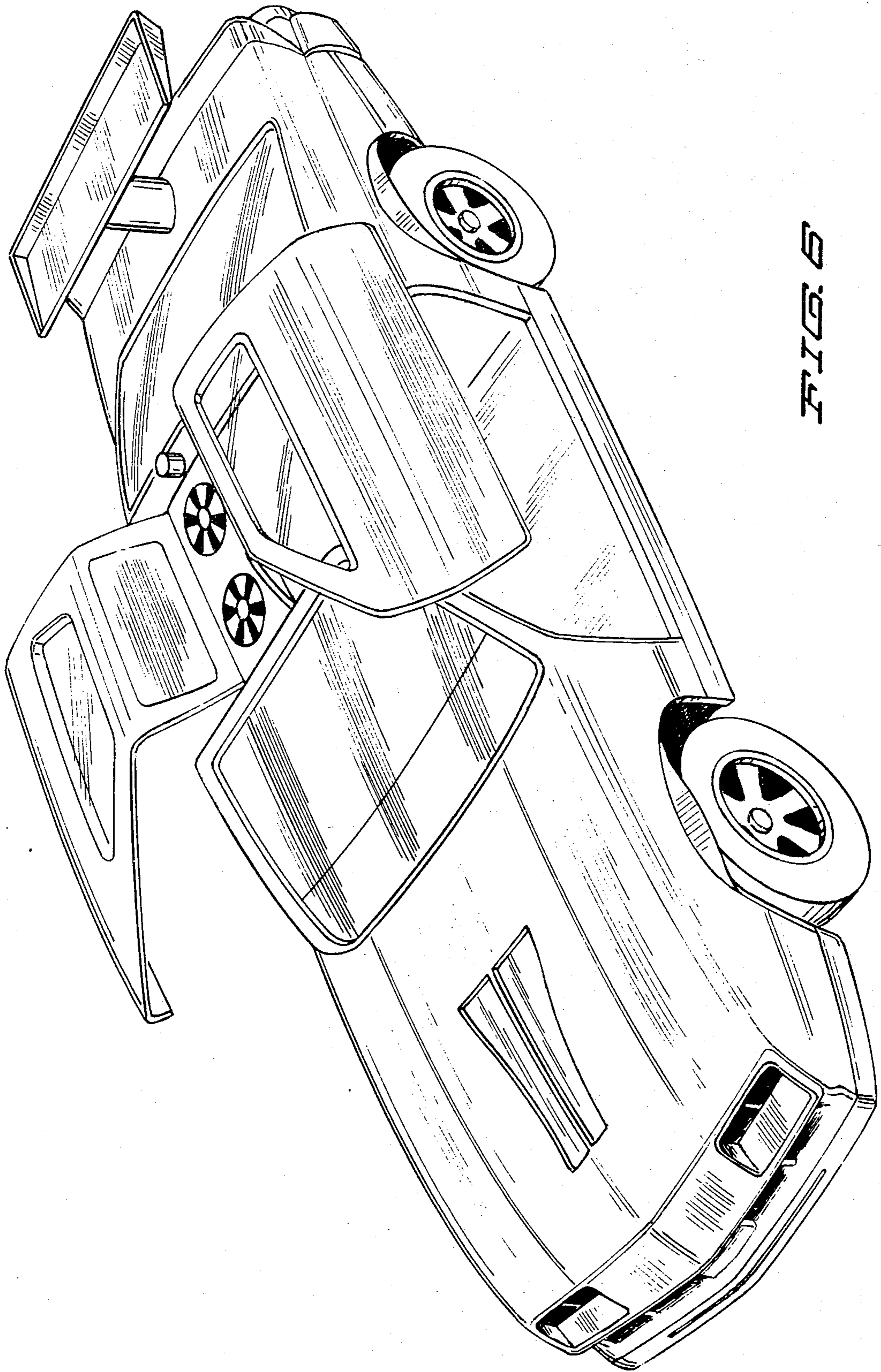

FIG. 6