

[54] REMOTELY CONTROLLED UNDERWATER VEHICLE

[75] Inventor: Graham S. Hawkes, Oakland, Calif.

[73] Assignee: Deep Ocean Engineering Incorporated, Oakland, Calif.

[\*\*] Term: 14 Years

[21] Appl. No.: 754,757

[22] Filed: Jul. 15, 1985

[52] U.S. Cl. .... D12/308

[58] Field of Search ..... D12/308, 300; D21/130, D21/128; 114/312, 322, 330, 331, 332, 337

[56] References Cited

U.S. PATENT DOCUMENTS

- 3,613,615 10/1971 Sturm ..... 114/331
- 4,212,258 7/1980 Collins ..... 114/312

4,333,414 6/1982 Hauz ..... 114/322

Primary Examiner—James M. Gandy

Assistant Examiner—Kay H. Chin

Attorney, Agent, or Firm—Manfred M. Warren; Robert B. Chickering; Glen R. Grunewald

[57] CLAIM

The ornamental design for a remotely controlled underwater vehicle, as shown.

DESCRIPTION

FIG. 1 is a top perspective view of a remotely controlled underwater vehicle showing my new design; FIG. 2 is a side elevation view thereof; FIG. 3 is a top plan view thereof; FIG. 4 is a bottom plan view thereof; FIG. 5 is a side elevation view of the side opposite to FIG. 2; FIG. 6 is a rear elevation view thereof; and FIG. 7 is a front elevation view thereof.

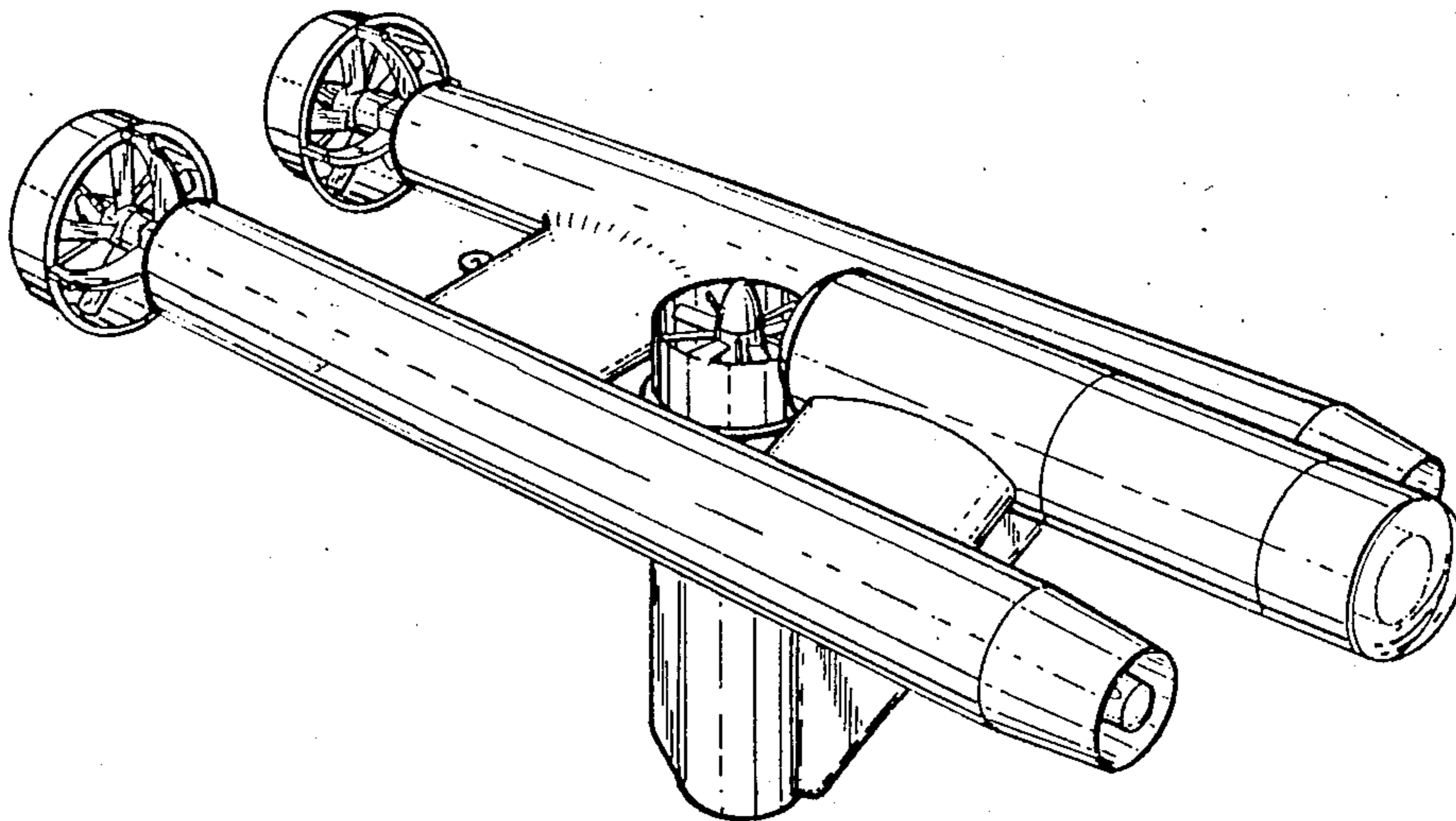

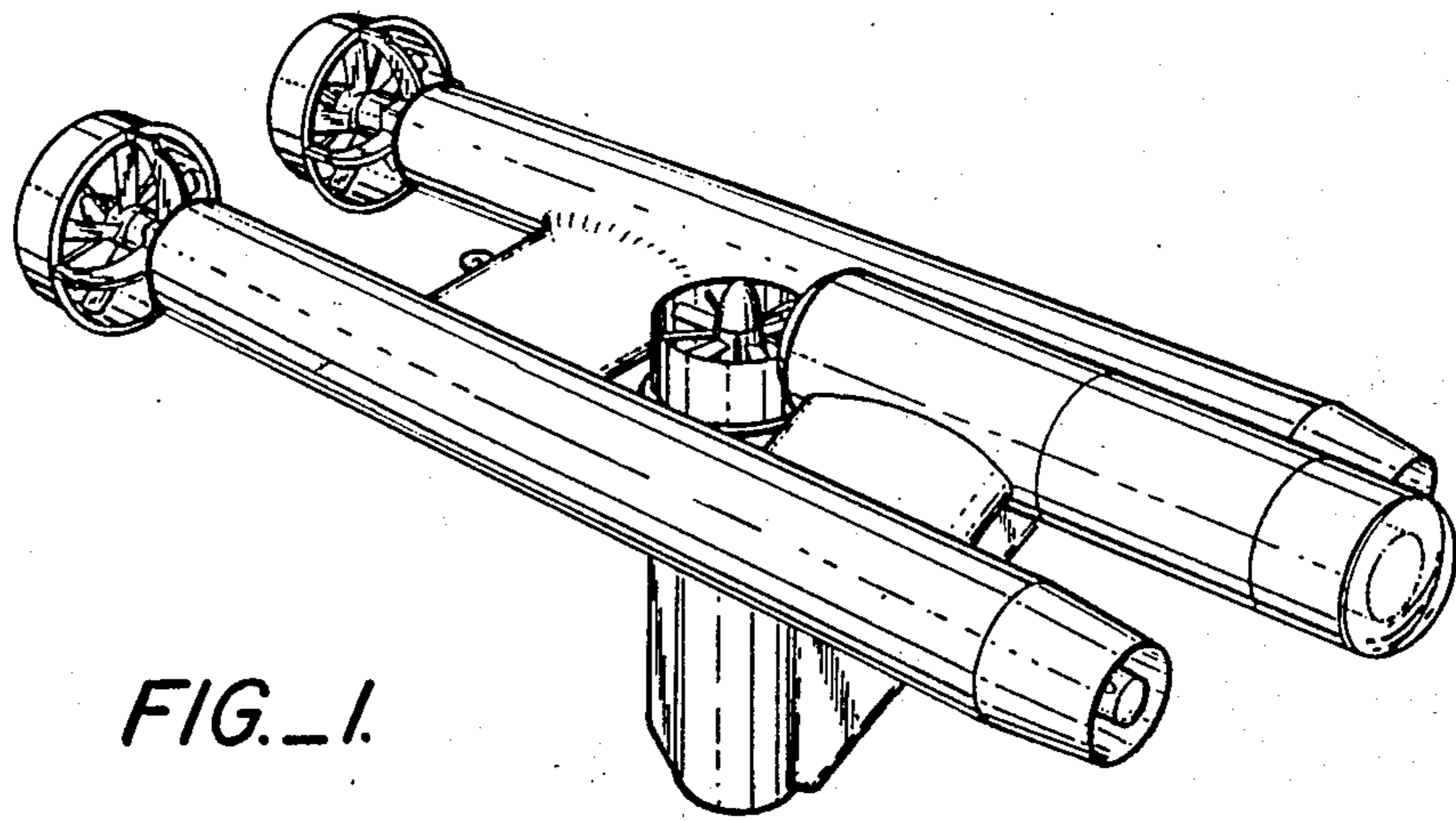

FIG.\_1.

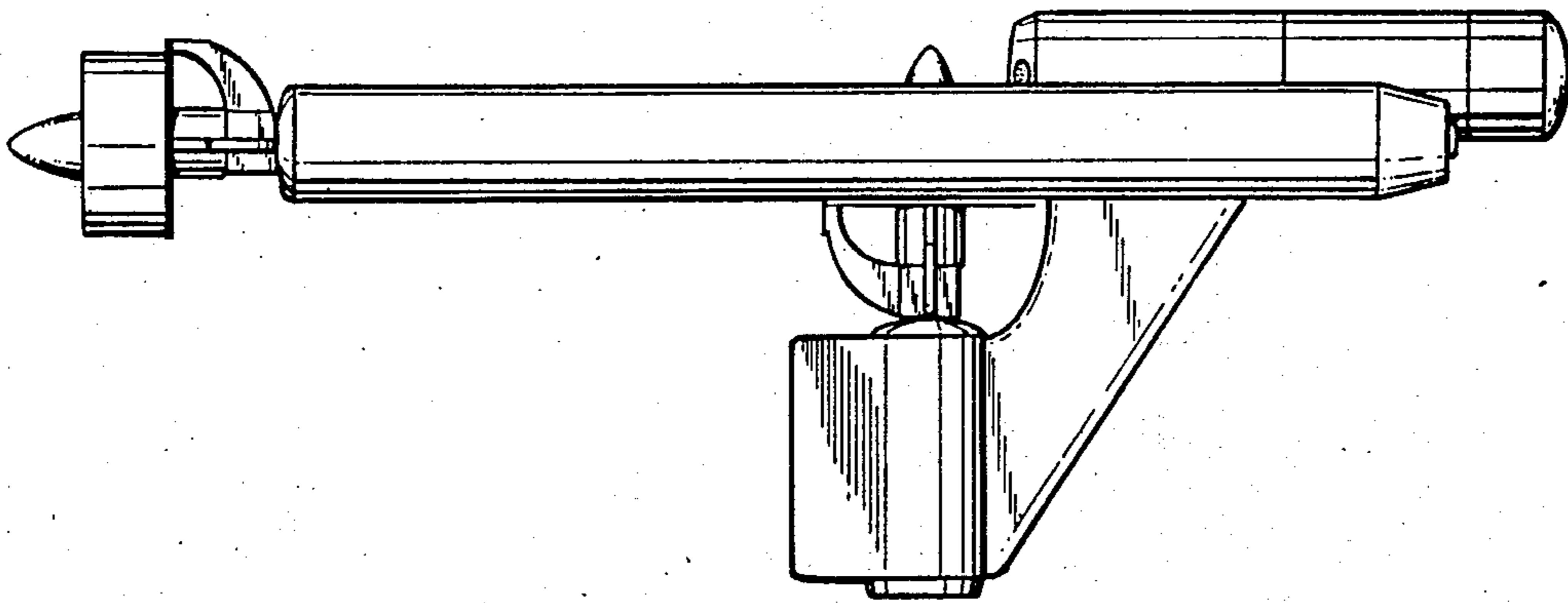

FIG.\_2.

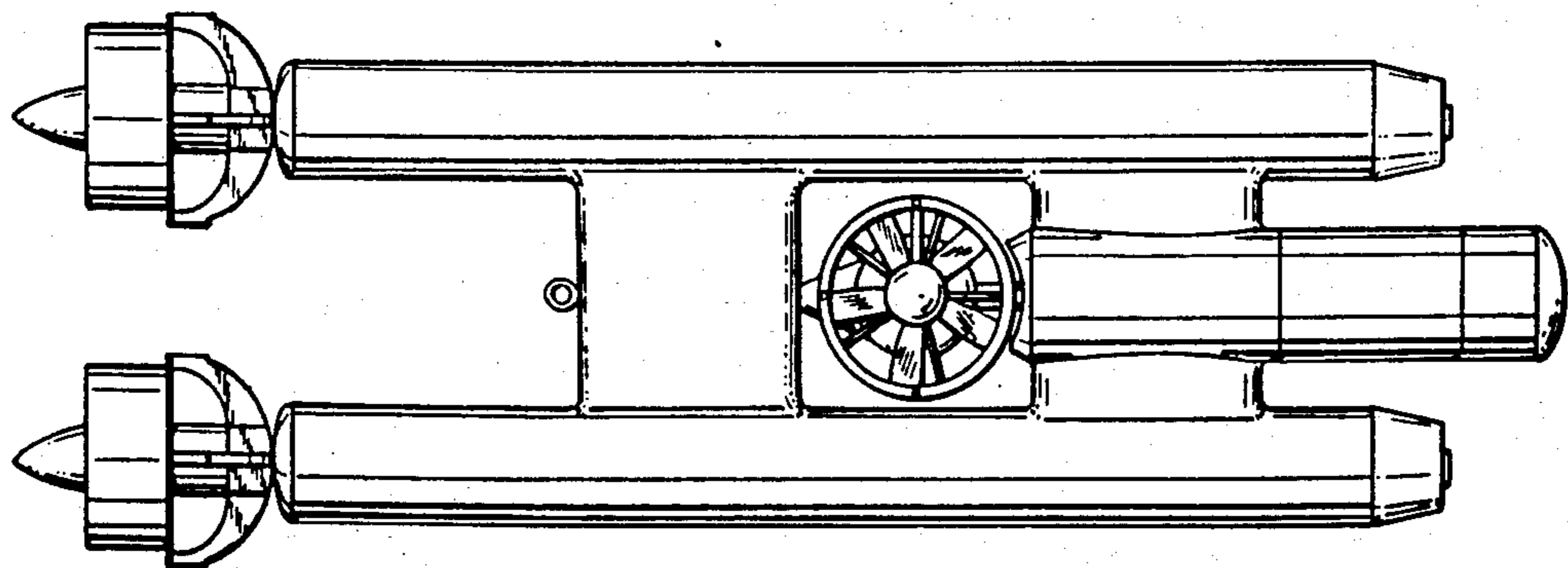

FIG.\_3.

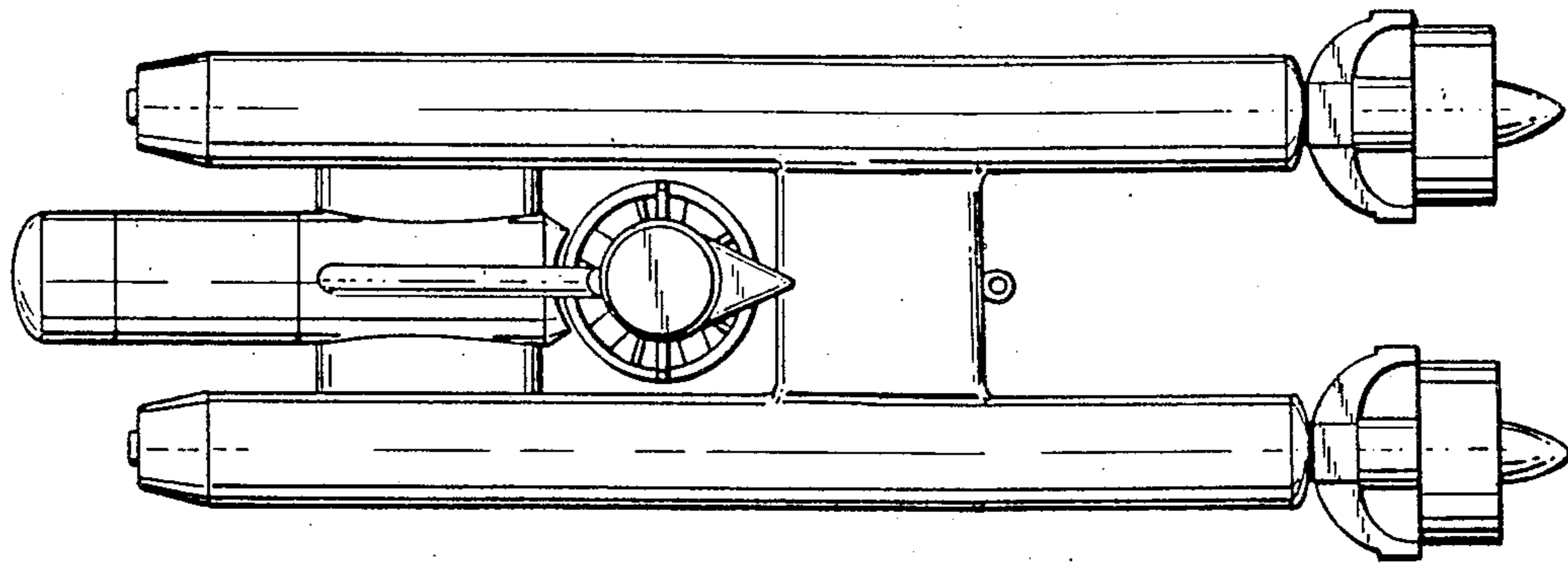

FIG.\_4.

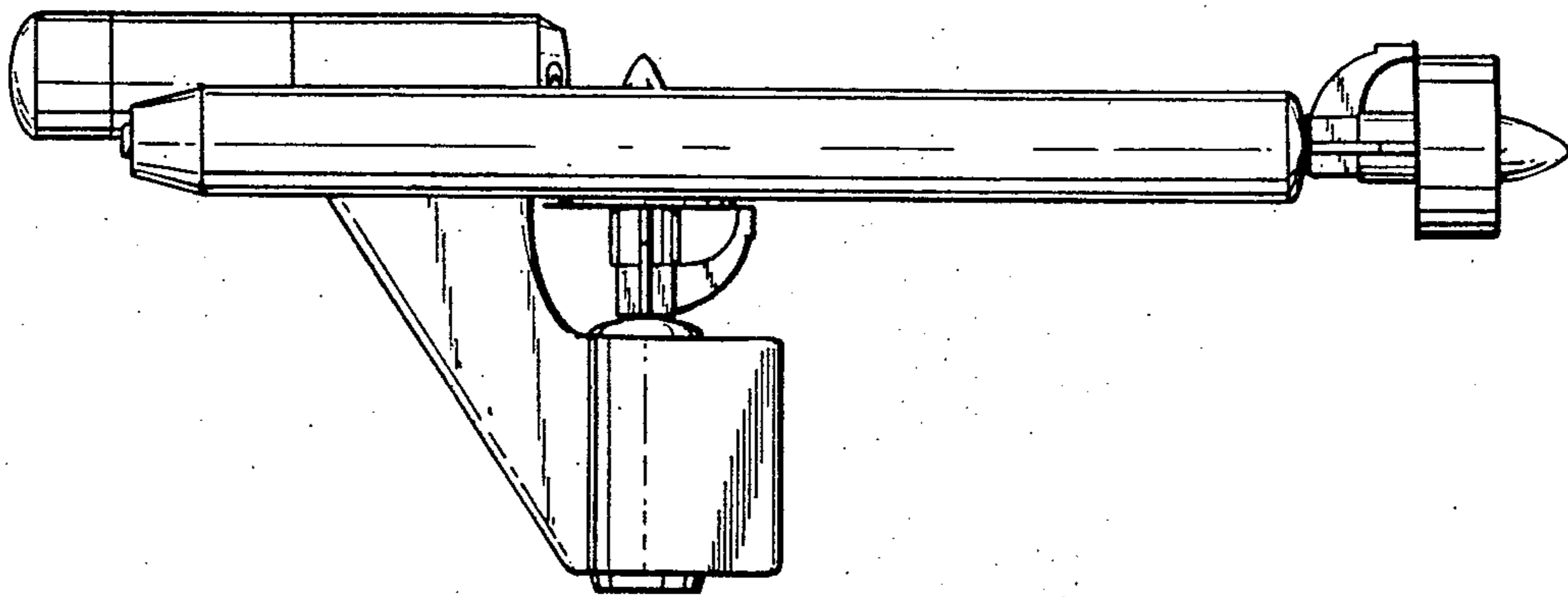

FIG.\_5.

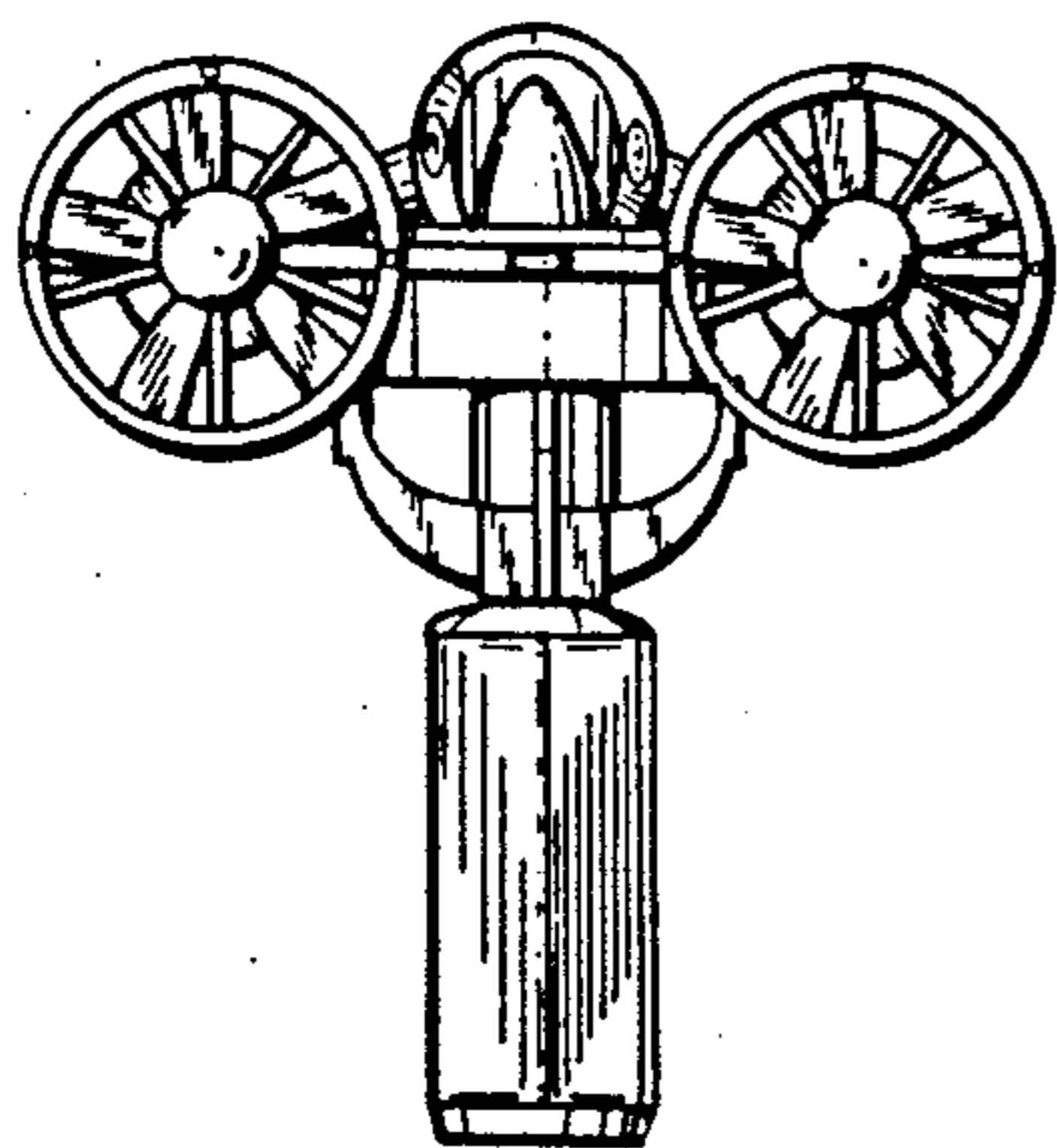

FIG.\_6.

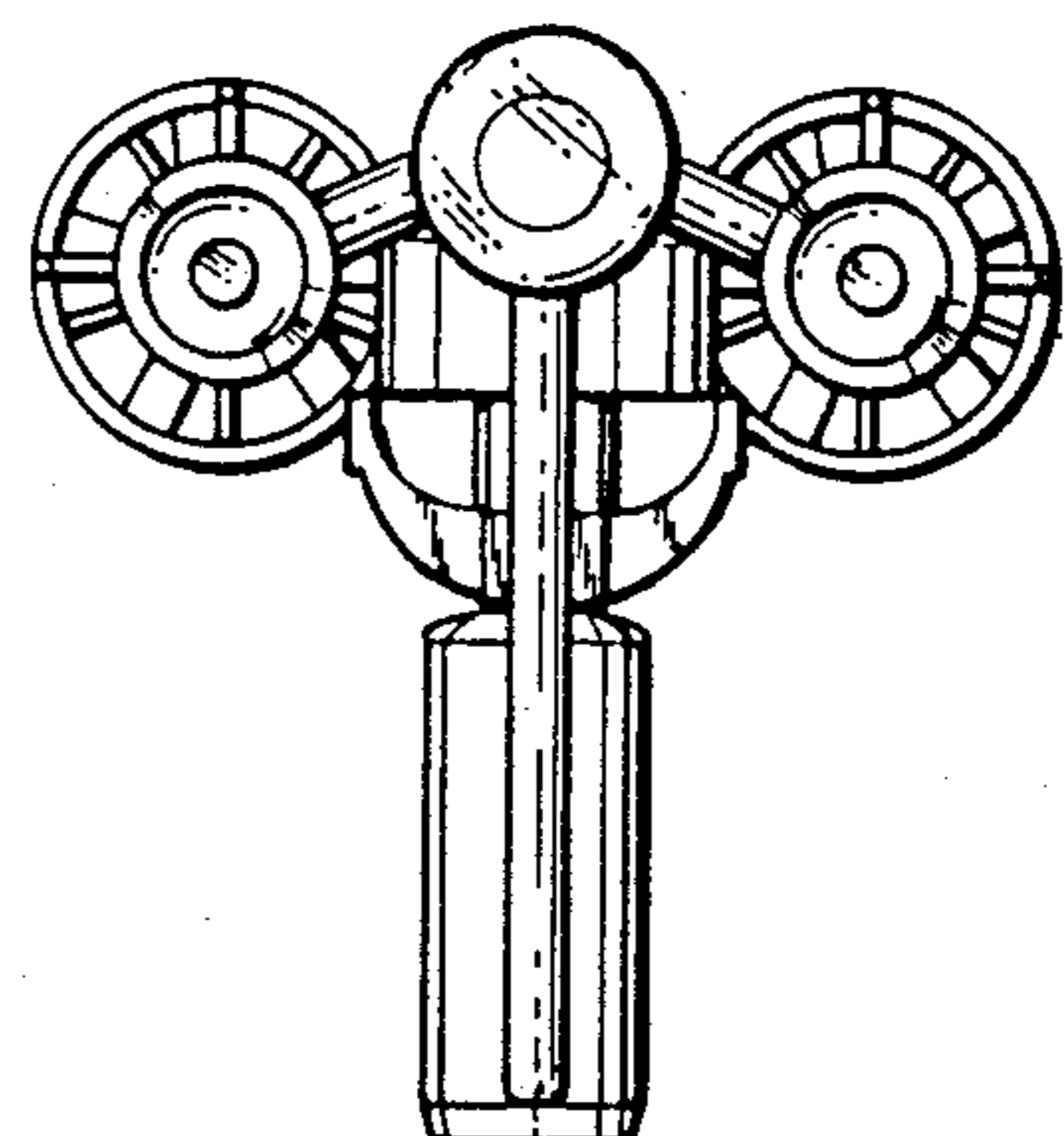

FIG.\_7.