

[54] VEHICLE WHEEL CENTER

[75] Inventor: Donald J. Reid, Plymouth, Mich.

[73] Assignee: Kelsey-Hayes Company, Romulus, Mich.

[**] Term: 14 Years

[21] Appl. No.: 764,827

[22] Filed: Aug. 12, 1985

[52] U.S. Cl. D12/211

[58] Field of Search D12/209, 211; 301/37 R, 301/63 R, 64 R, 64 SD, 65

[56] References Cited

U.S. PATENT DOCUMENTS

- D. 267,564 1/1983 Wright D12/211
- D. 275,665 9/1984 deVries D12/211

OTHER PUBLICATIONS

Motor Trend, 10/80, p. 75, Mazda GLC Wheel, bottom center of page.

Primary Examiner—James M. Gandy
Attorney, Agent, or Firm—Ralph J. Skinkiss; David L. Kuhn

[57] CLAIM

The ornamental design for a vehicle wheel center, as shown and described.

DESCRIPTION

FIG. 1 is a front elevational view of a vehicle wheel center showing my new design.

FIG. 2 is a sectional view taken along line 2—2 in FIG. 1.

FIG. 3 is a sectional view taken along line 3—3 in FIG. 1.

FIG. 4 is a sectional view taken along line 4—4 in FIG. 1.

FIG. 5 is a sectional view taken along line 5—5 in FIG. 1.

The broken lines in the drawing are for illustrative purposes only and form no part of the claimed design.

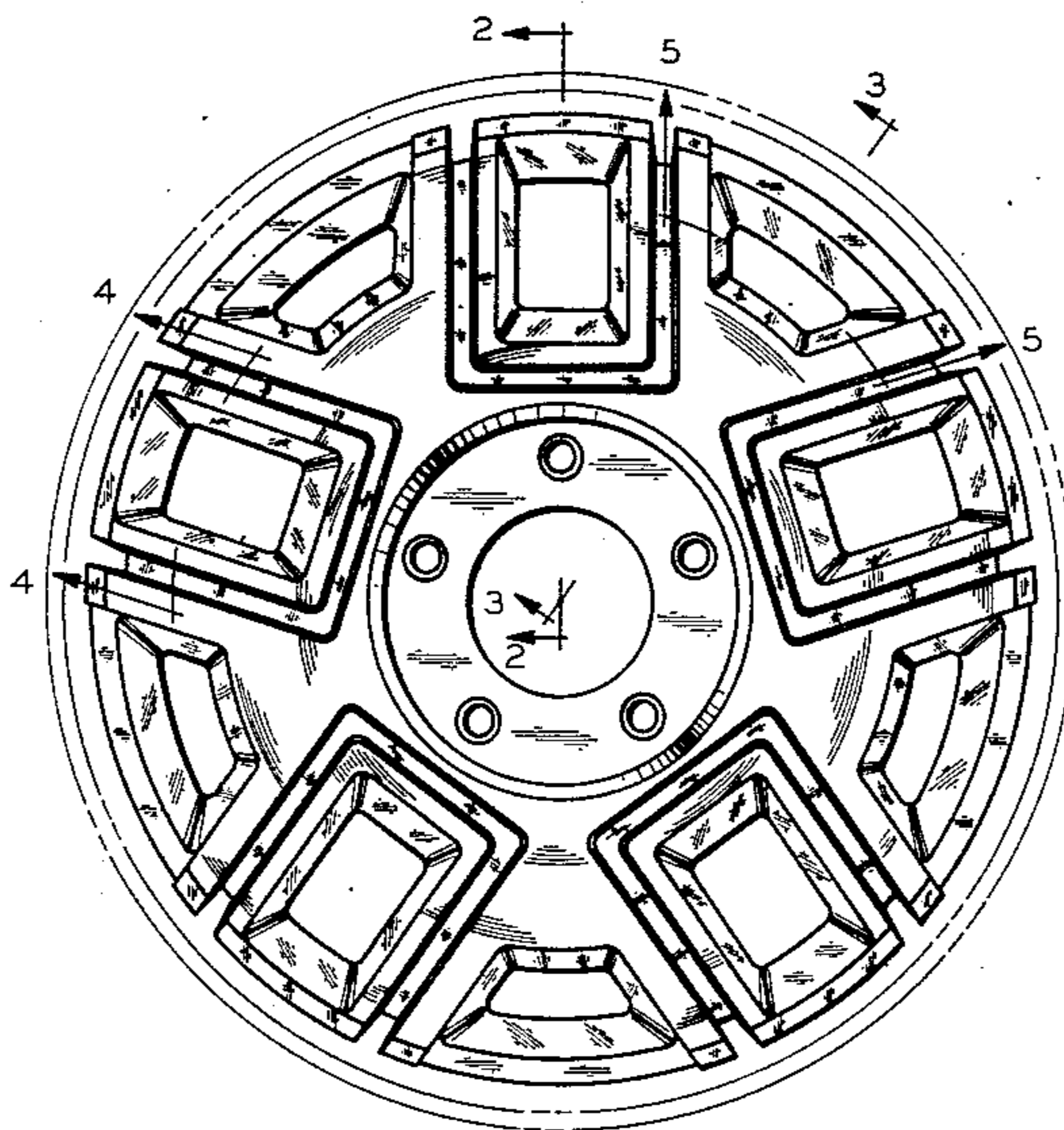

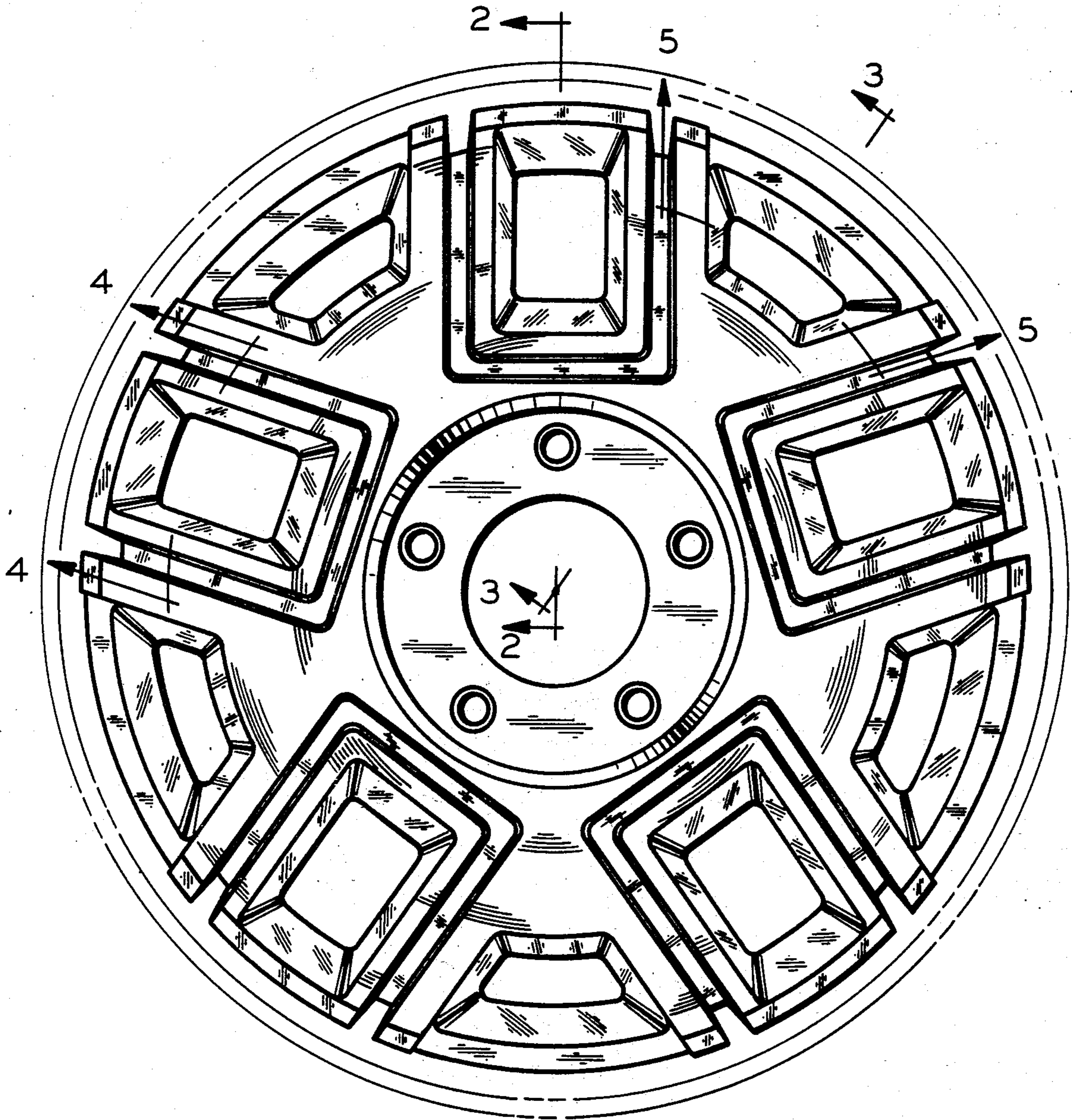

— FIG. 1

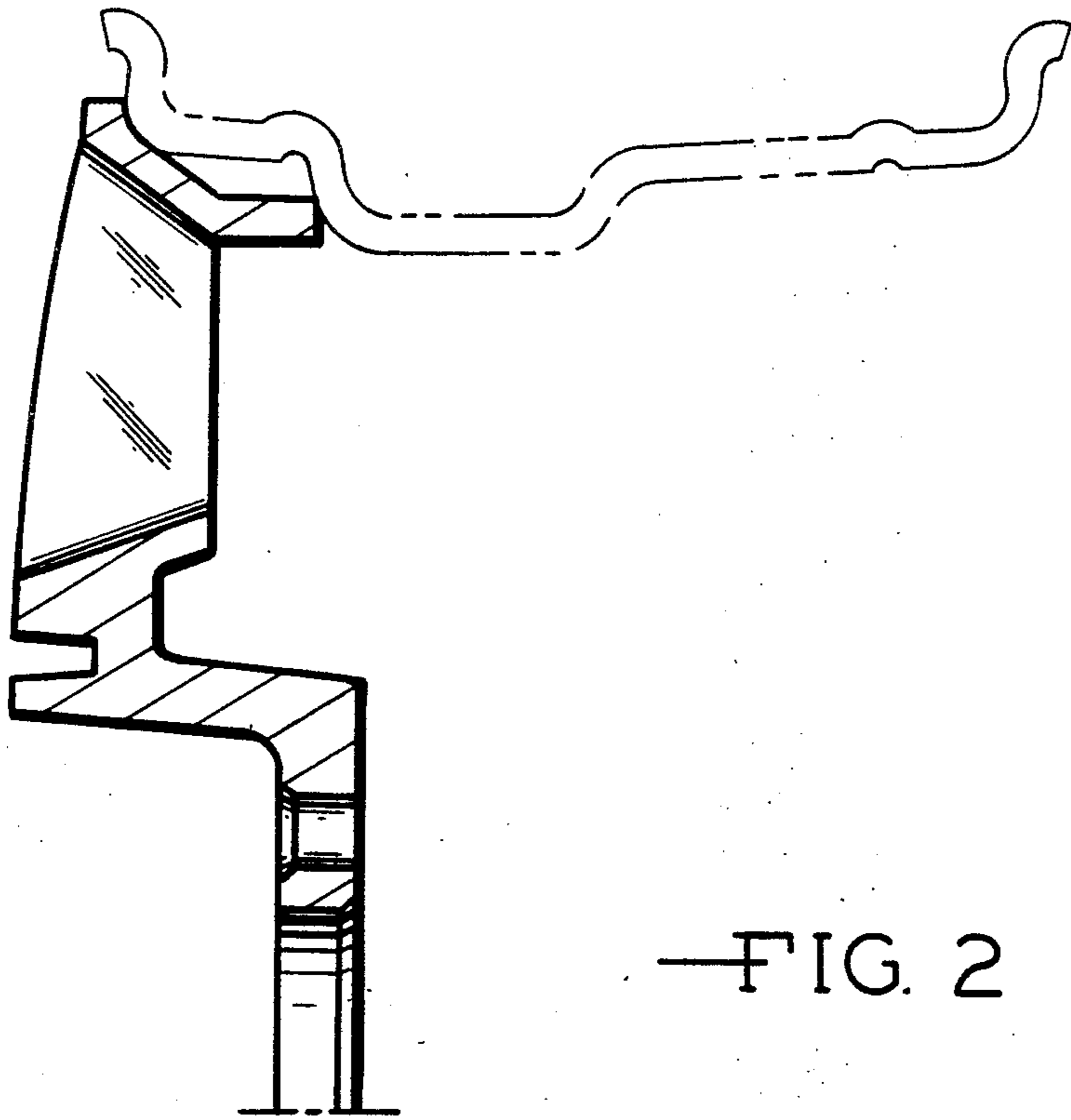

—FIG. 2

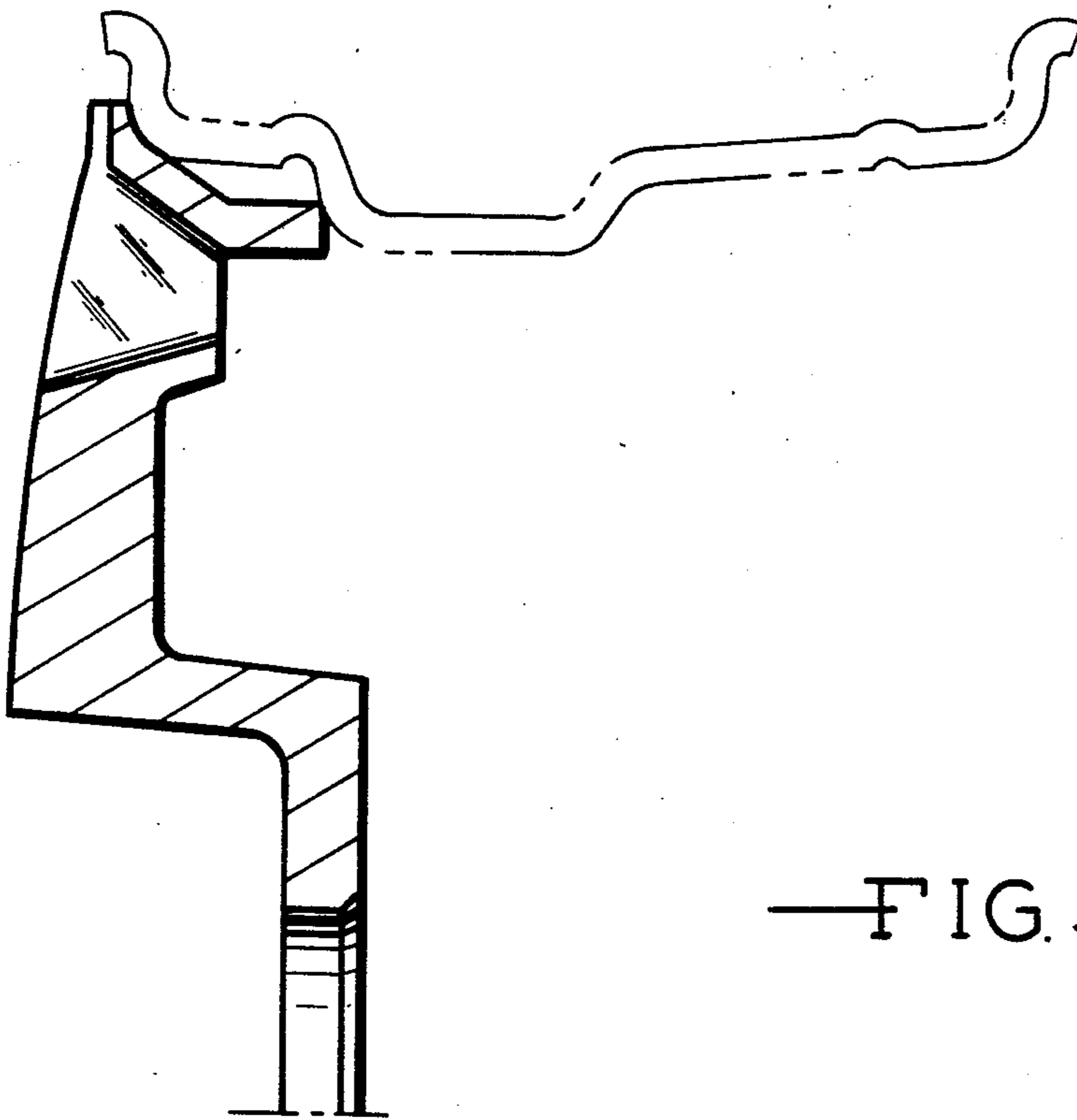

—FIG. 3

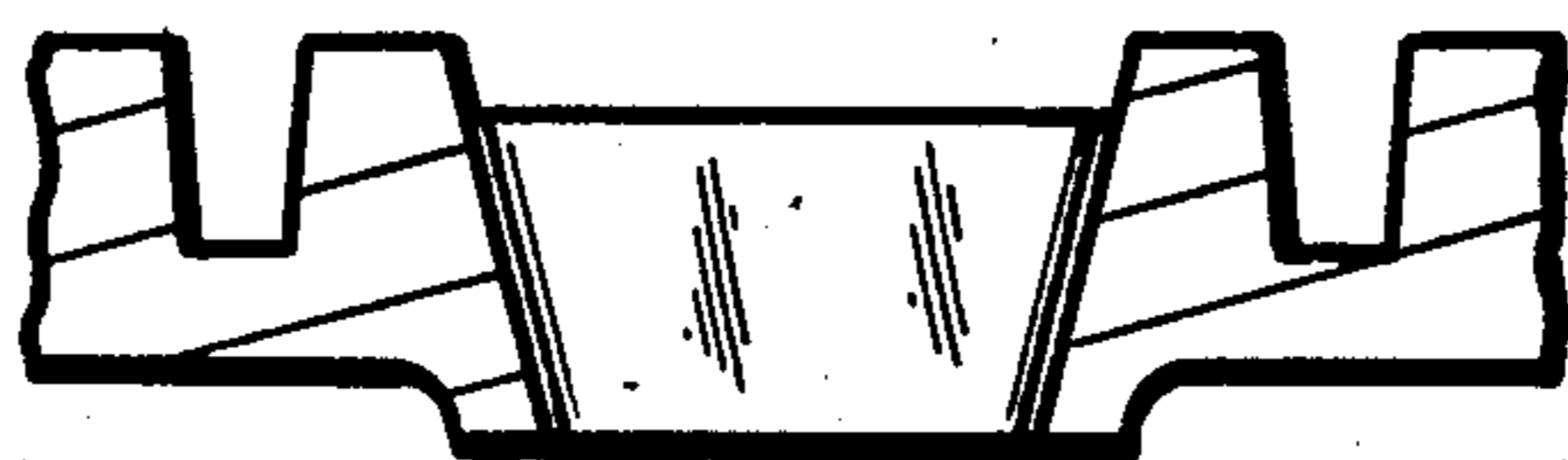

FIG. 4

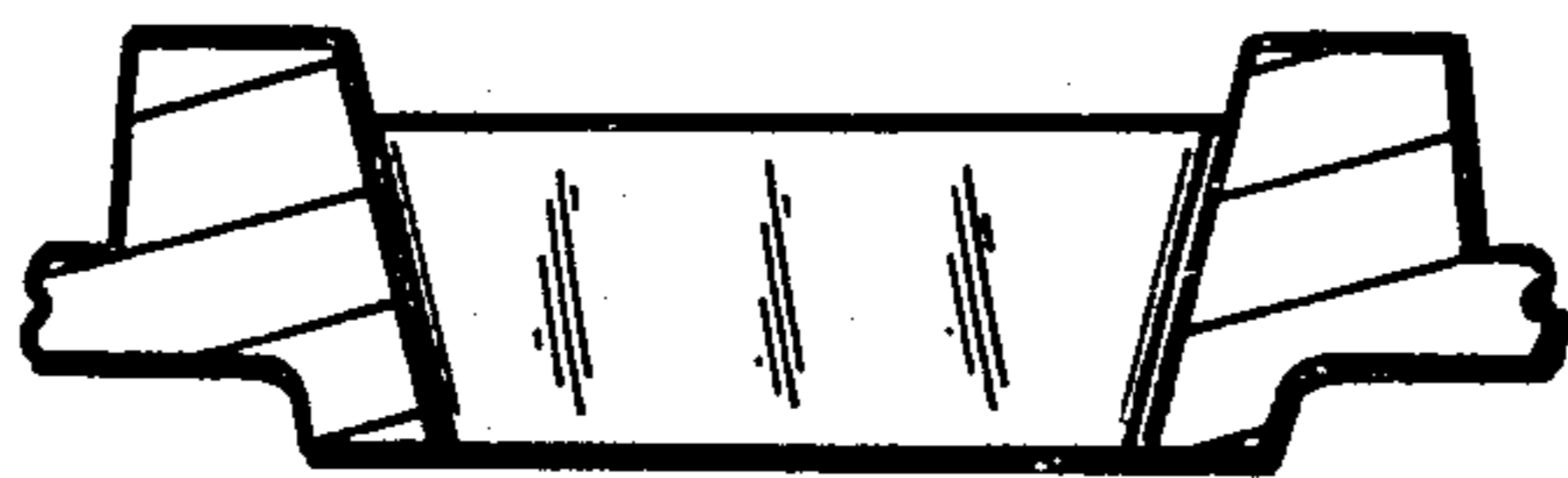

FIG. 5