

[54] WHEEL

[75] Inventor: Ulf Bruder, Göteborg, Sweden

[73] Assignee: Innofibre AB, Göteborg, Sweden

[**] Term: 14 Years

[21] Appl. No.: 634,627

[22] Filed: Jul. 26, 1984

[30] Foreign Application Priority Data

Jan. 26, 1984 [SE] Sweden 84-0236

[52] U.S. Cl. D12/205

[58] Field of Search D12/205, 209, 211;
301/63 R, 64 R, 64 SD, 65

[56] References Cited

U.S. PATENT DOCUMENTS

D. 33,141	8/1900	Conner	D12/211
D. 45,097	12/1913	Walther	D12/211
D. 52,594	10/1918	Walther	D12/209
D. 244,272	5/1977	Raudman, Jr. et al.	D12/205
D. 248,390	7/1978	Lester	D12/205

OTHER PUBLICATIONS

Toys & Novelties, 5/47, p. 30, Front Wheel of Tricycle, center of page.

Primary Examiner—James M. Gandy
Attorney, Agent, or Firm—Balogh, Kramer, Dvorak, Genova & Traub

[57] CLAIM

The ornamental design for a wheel, as shown and described.

DESCRIPTION

FIG. 1 is an elevated front perspective view of the wheel;
FIG. 2 is a less-elevated front perspective view of the wheel; and
FIG. 3 is a front elevation view, it being understood that the rear is a mirror image thereof.
FIG. 4 is a section view taken along line 4—4 in FIG. 3 through one of the spokes of the wheel;
FIG. 5 is a side elevation view, it being understood that the opposite side is a mirror image thereof; and
FIG. 6 is a bottom plan view, it being understood that the top is a mirror image thereof.

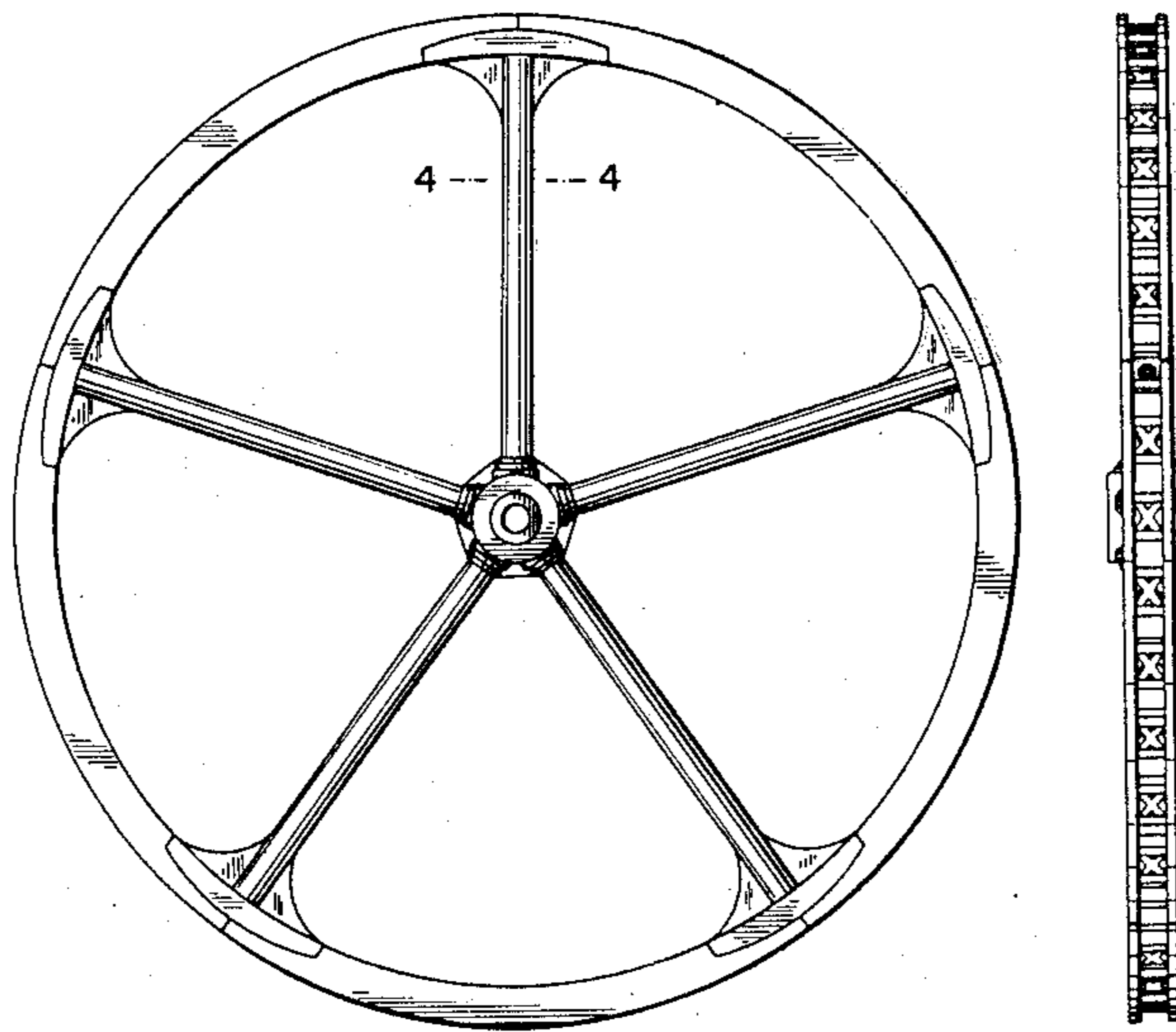

FIG. 1

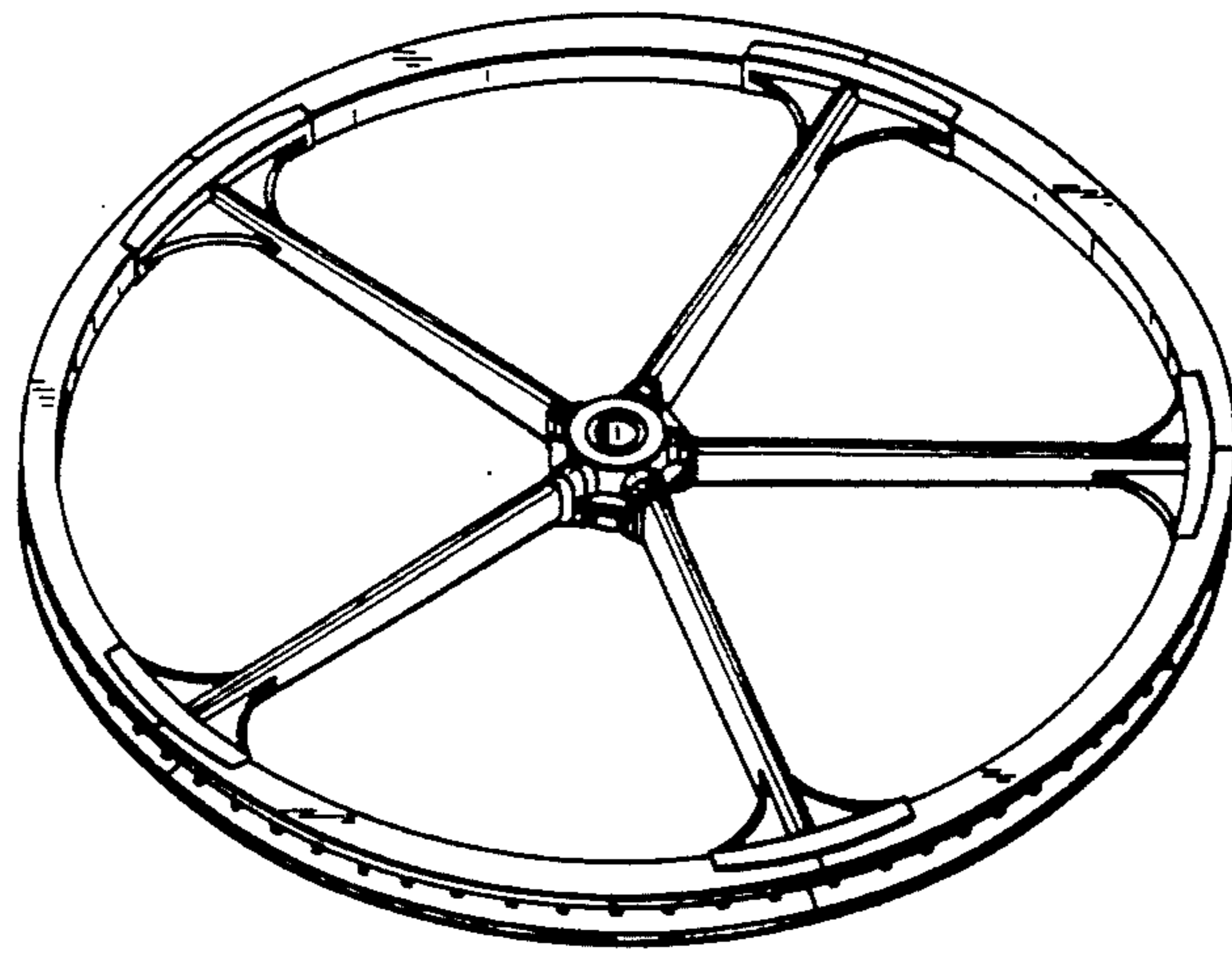
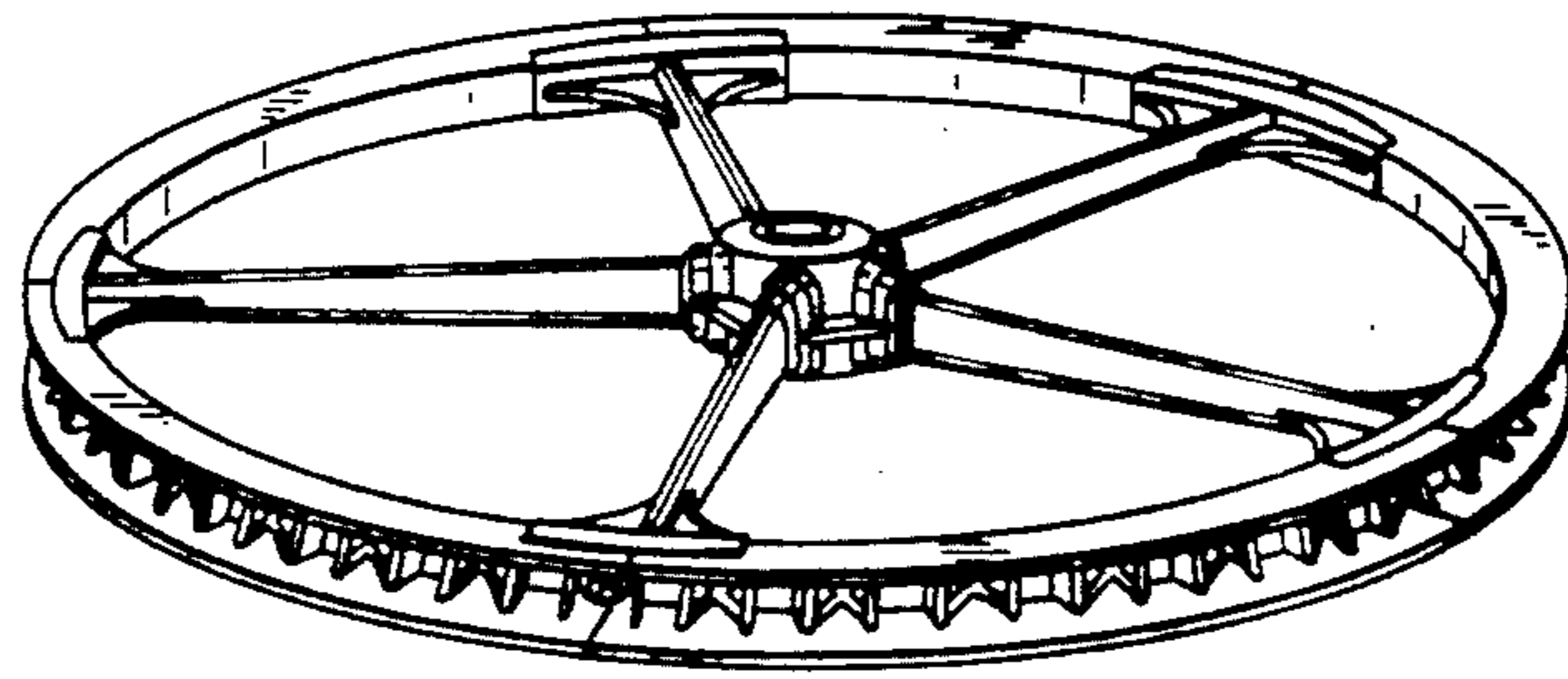

FIG. 2



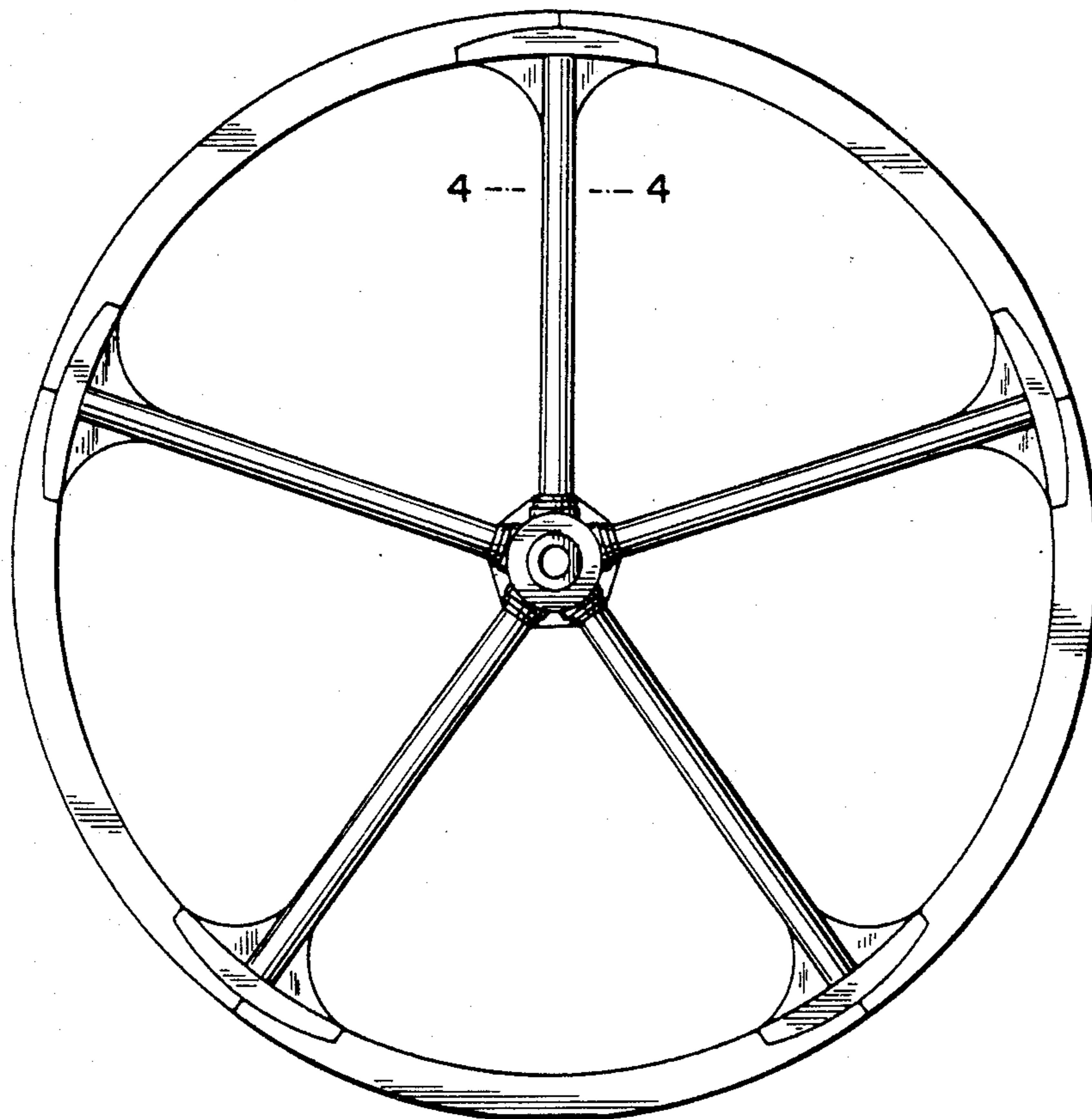

FIG. 3

FIG. 5



FIG. 6



FIG. 4