

[54] **WIND DEFLECTOR FOR VEHICLES**

[76] **Inventor: Mark A. Mayhugh, 3324 S. Glen Park Ct., New Berlin, Wis. 53151**

[\*\*] **Term: 14 Years**

[21] **Appl. No.: 785,573**

[22] **Filed: Oct. 8, 1985**

[52] **U.S. Cl. .... D12/181**

[58] **Field of Search ..... D12/81; 296/1 S, 91**

[56] **References Cited**

**U.S. PATENT DOCUMENTS**

4,131,308 12/1978 Holka et al. .... 296/1 S

**FOREIGN PATENT DOCUMENTS**

747765 7/1980 U.S.S.R. .... 296/1 S

*Primary Examiner—James M. Gandy*

*Attorney, Agent, or Firm—Andrus, Scales, Starke & Sawall*

[57] **CLAIM**

The ornamental design for a wind deflector for vehicles, as shown and described.

**DESCRIPTION**

FIG. 1 is a front perspective view of a wind deflector for vehicles showing my new design; FIG. 2 is a side elevation view thereof, it being understood that the broken lines are for illustrative purposes only;

FIG. 3 is a front elevation view thereof;

FIG. 4 is a top plan view thereof;

FIG. 5 is a rear elevation view thereof;

FIG. 6 is a bottom plan view thereof; and

FIG. 7 is a front perspective view of a wind deflector for vehicles showing a second embodiment of my new design, wherein the sole difference resides in the configuration of the top central surface thereof.

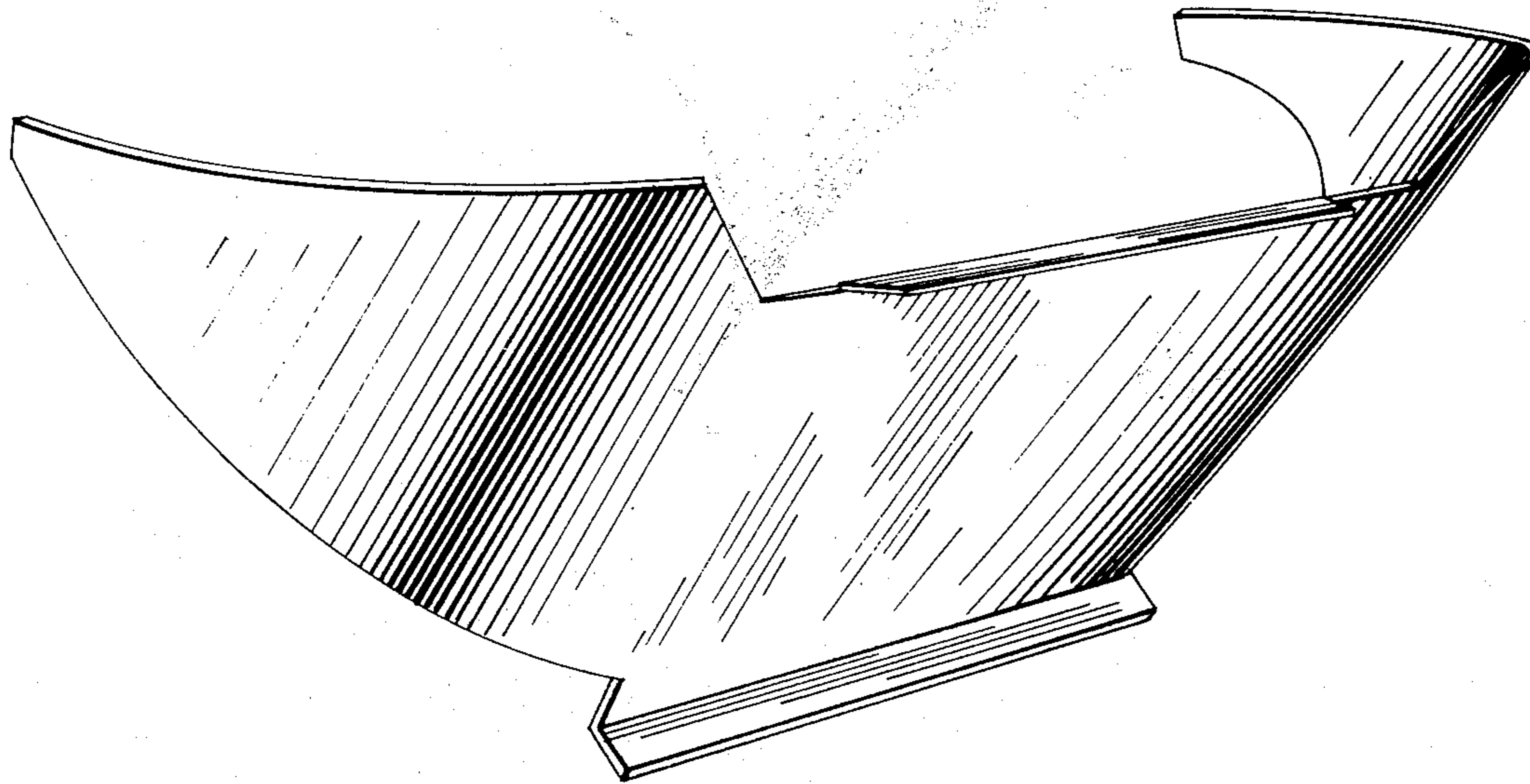

FIG. 1

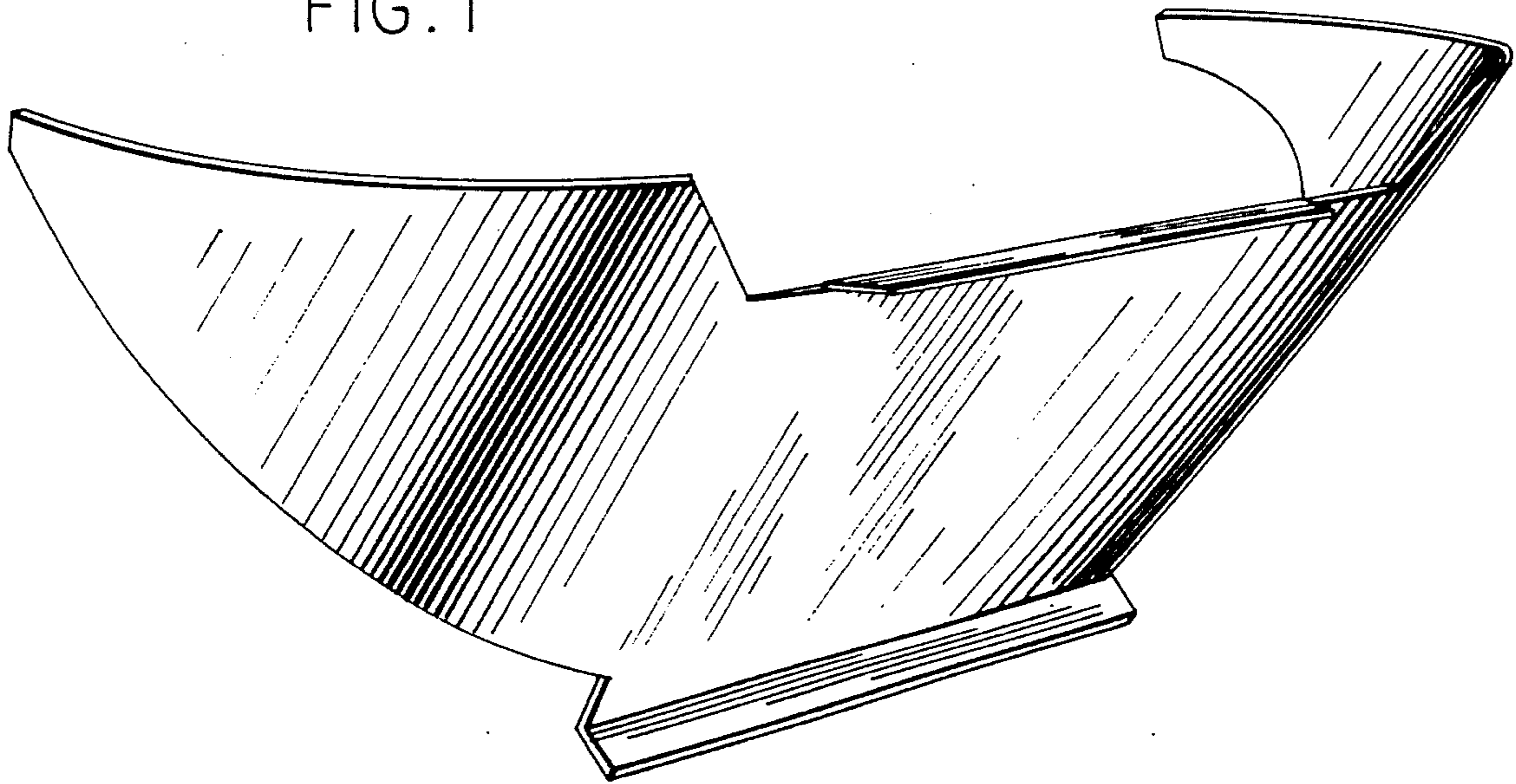

FIG. 2

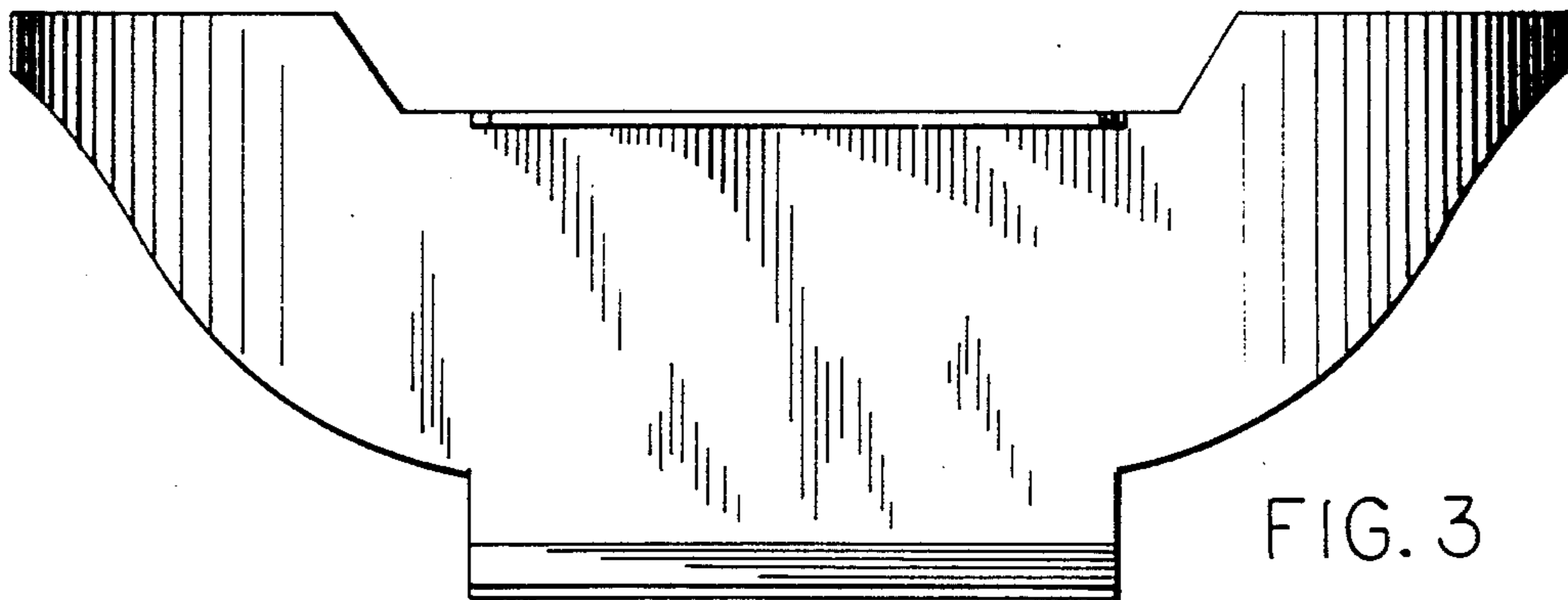
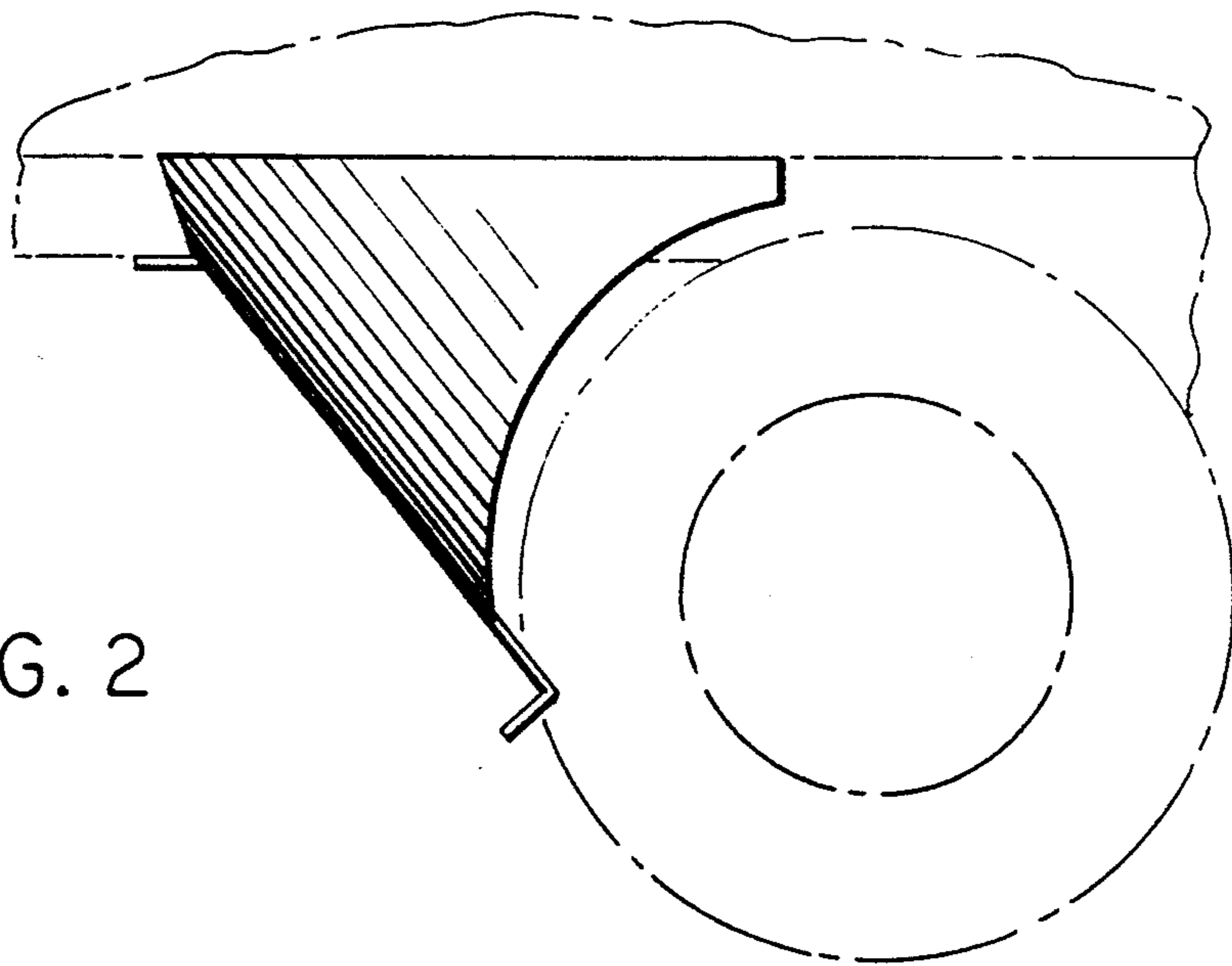

FIG. 3

FIG. 4

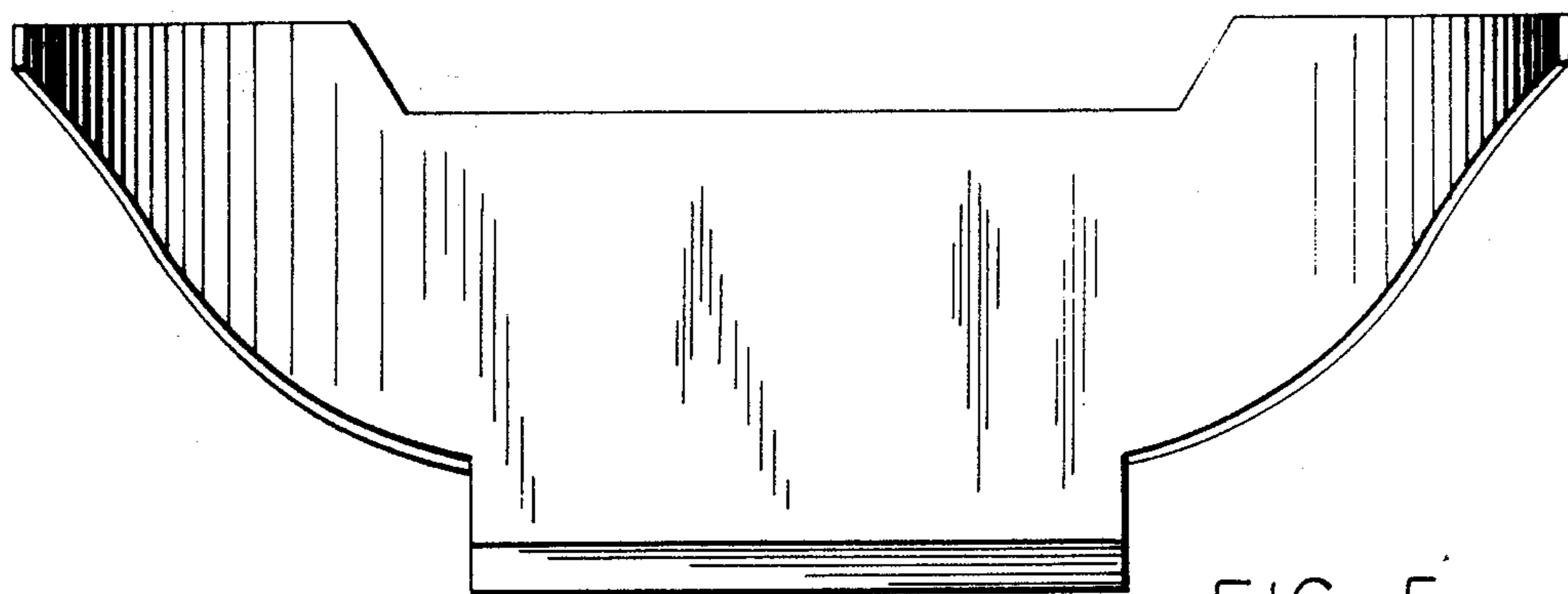
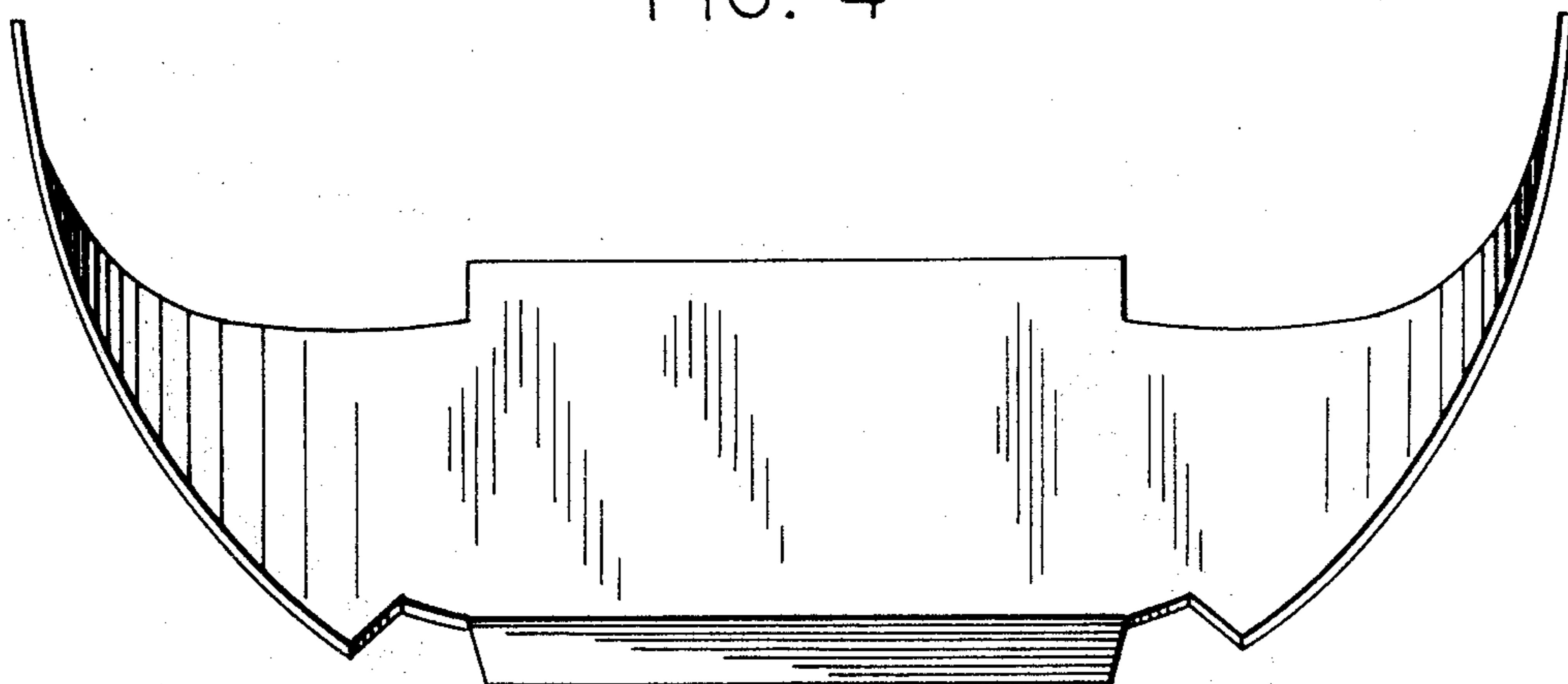

FIG. 5

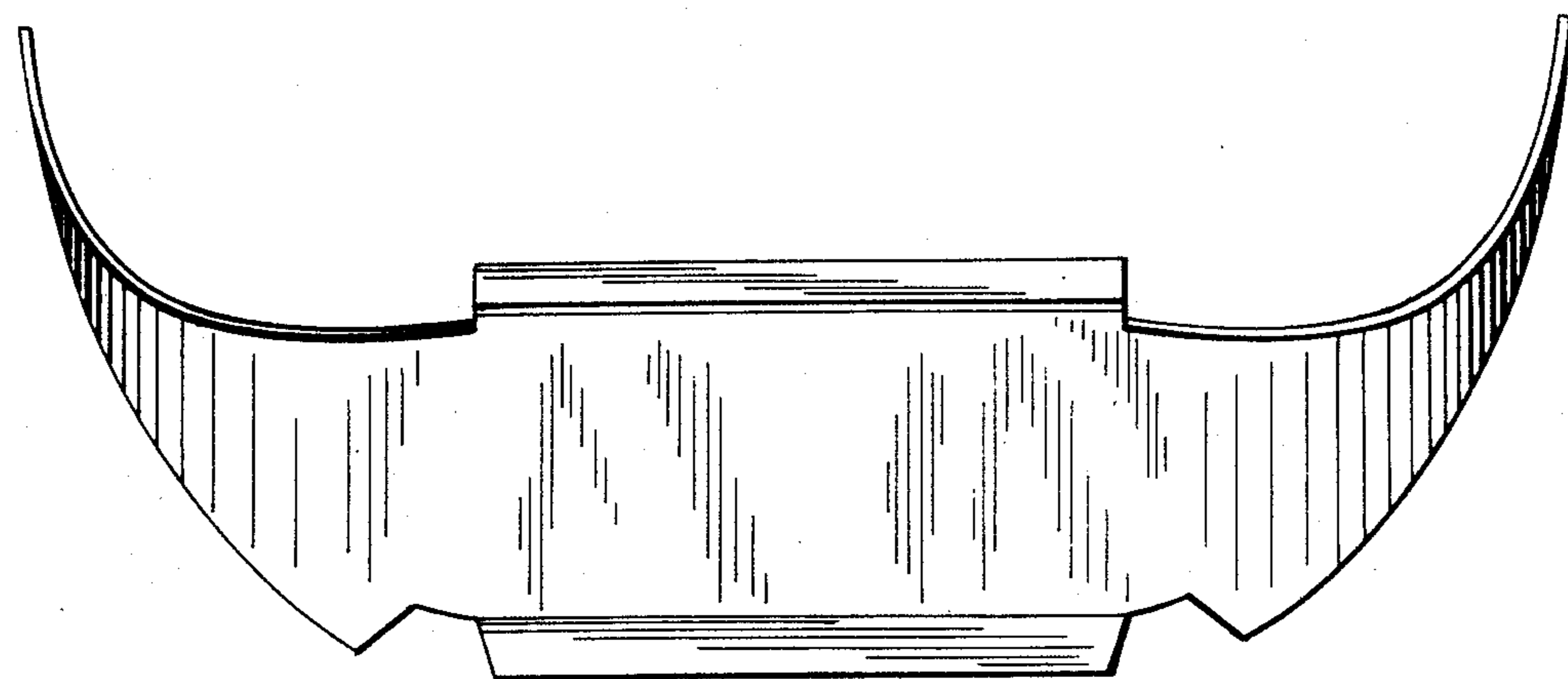

FIG. 6

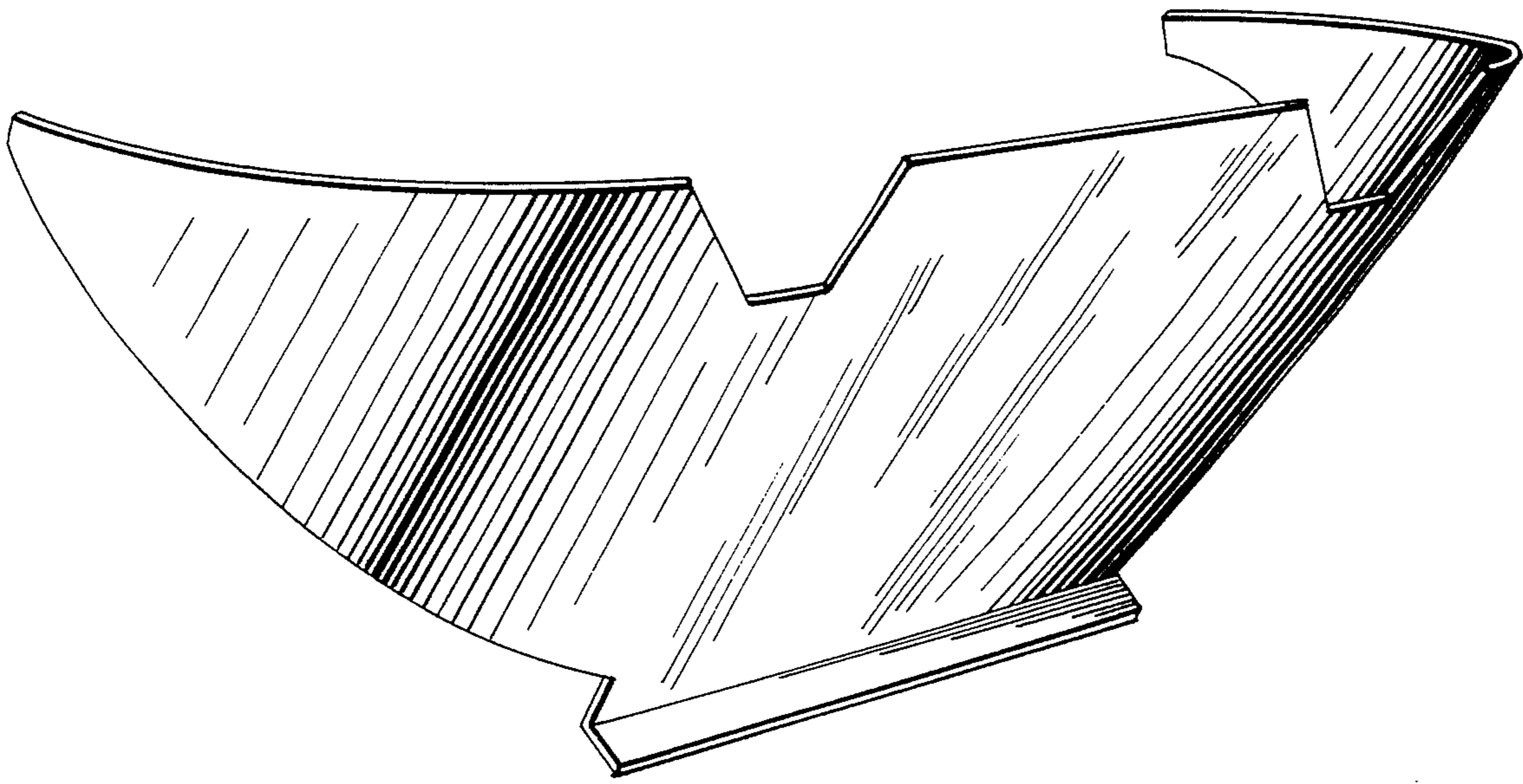

FIG. 7