

[54] RECONFIGURABLE TOY VEHICLE

[75] Inventor: Akio Kitamura, Tokyo, Japan

[73] Assignee: Takara Co., Ltd., Tokyo, Japan

[**] Term: 14 Years

[21] Appl. No.: 715,064

[22] Filed: Mar. 21, 1985

[30] Foreign Application Priority Data

Oct. 25, 1984 [JP] Japan 59-44102

[52] U.S. Cl. D21/150

[58] Field of Search D21/128, 136, 137, 150, D21/166; 446/71-75, 78, 275, 376, 378, 95, 80, 93

[56] References Cited

U.S. PATENT DOCUMENTS

- D. 253,193 10/1979 Pauly et al. D21/136
- D. 262,564 1/1982 Yamashina D21/136
- D. 277,494 2/1985 Lerch D21/136
- D. 279,307 6/1985 Murakami D21/136
- D. 283,717 5/1986 Obara D21/150
- 4,571,203 2/1986 Murakami 446/93

Primary Examiner—Charles A. Rademaker
Attorney, Agent, or Firm—Price, Gess & Ubell

[57] CLAIM

The ornamental design for a reconfigurable toy vehicle, substantially as shown and described.

DESCRIPTION

FIG. 1 is a perspective view reconfigurable toy vehicle showing my new design;
 FIG. 2 is a right side elevational view thereof, the side opposite being a mirror image;
 FIG. 3 is a top plan view;
 FIG. 4 is a bottom plan view;
 FIG. 5 is a front elevational view;
 FIG. 6 is a rear elevational view;
 FIG. 7 is a perspective view of the design shown in FIGS. 1 through 6 in a toy robot reconfiguration;
 FIG. 8 is a right side elevational view thereof, the side opposite being a mirror image;
 FIG. 9 is a top plan view;
 FIG. 10 is a bottom plan view;
 FIG. 11 is a front elevational view; and
 FIG. 12 is rear elevational view.

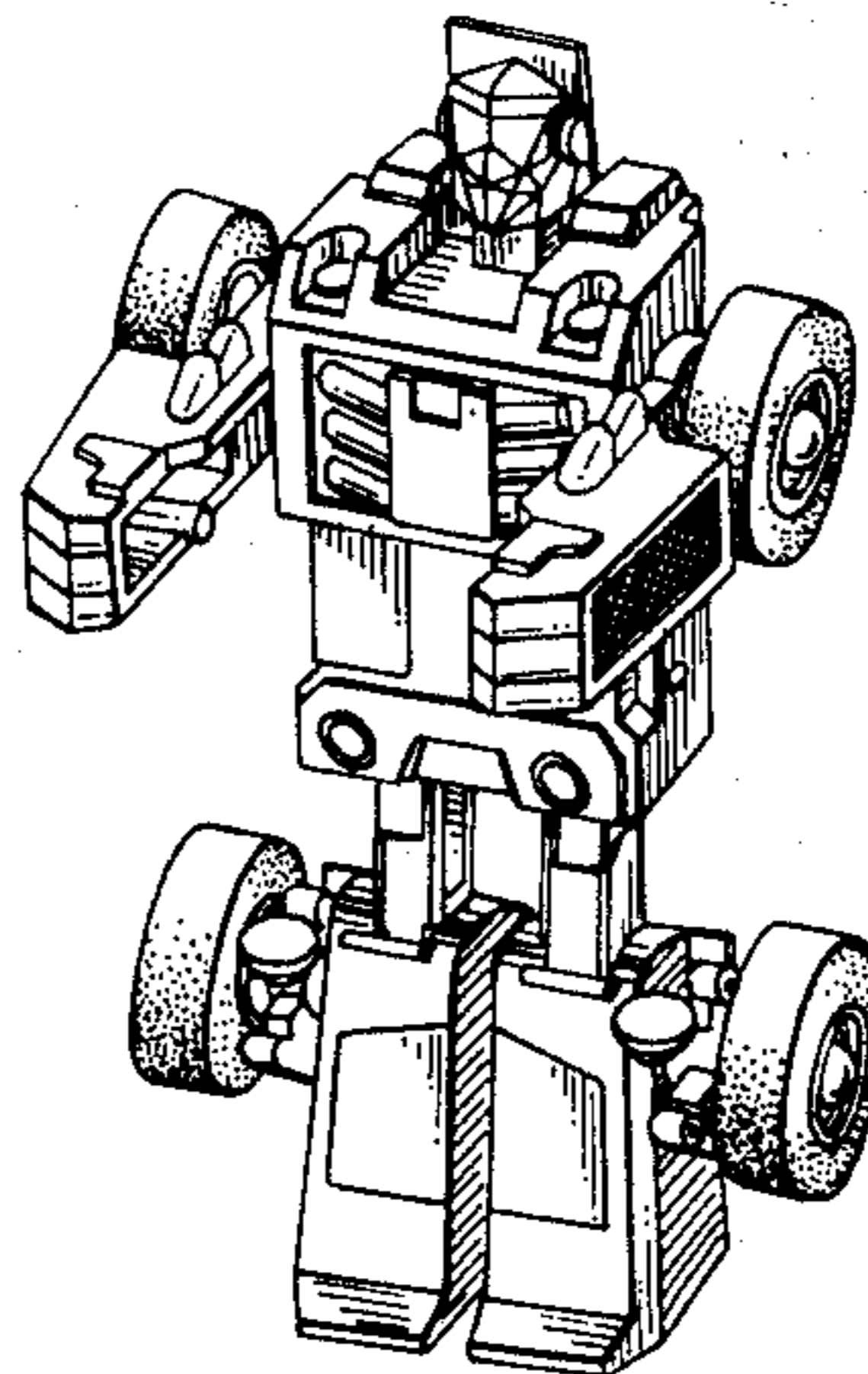
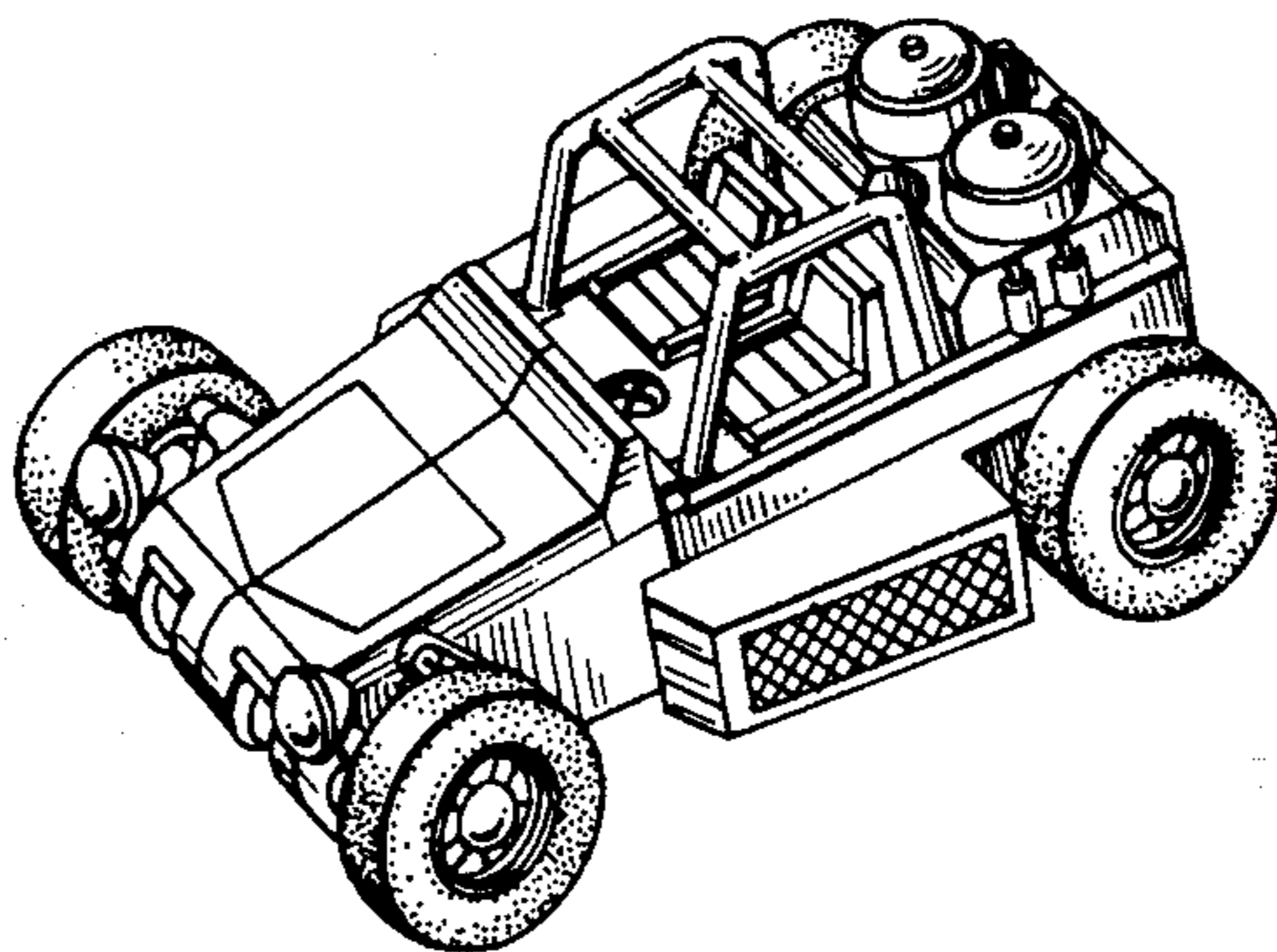

FIG. 1

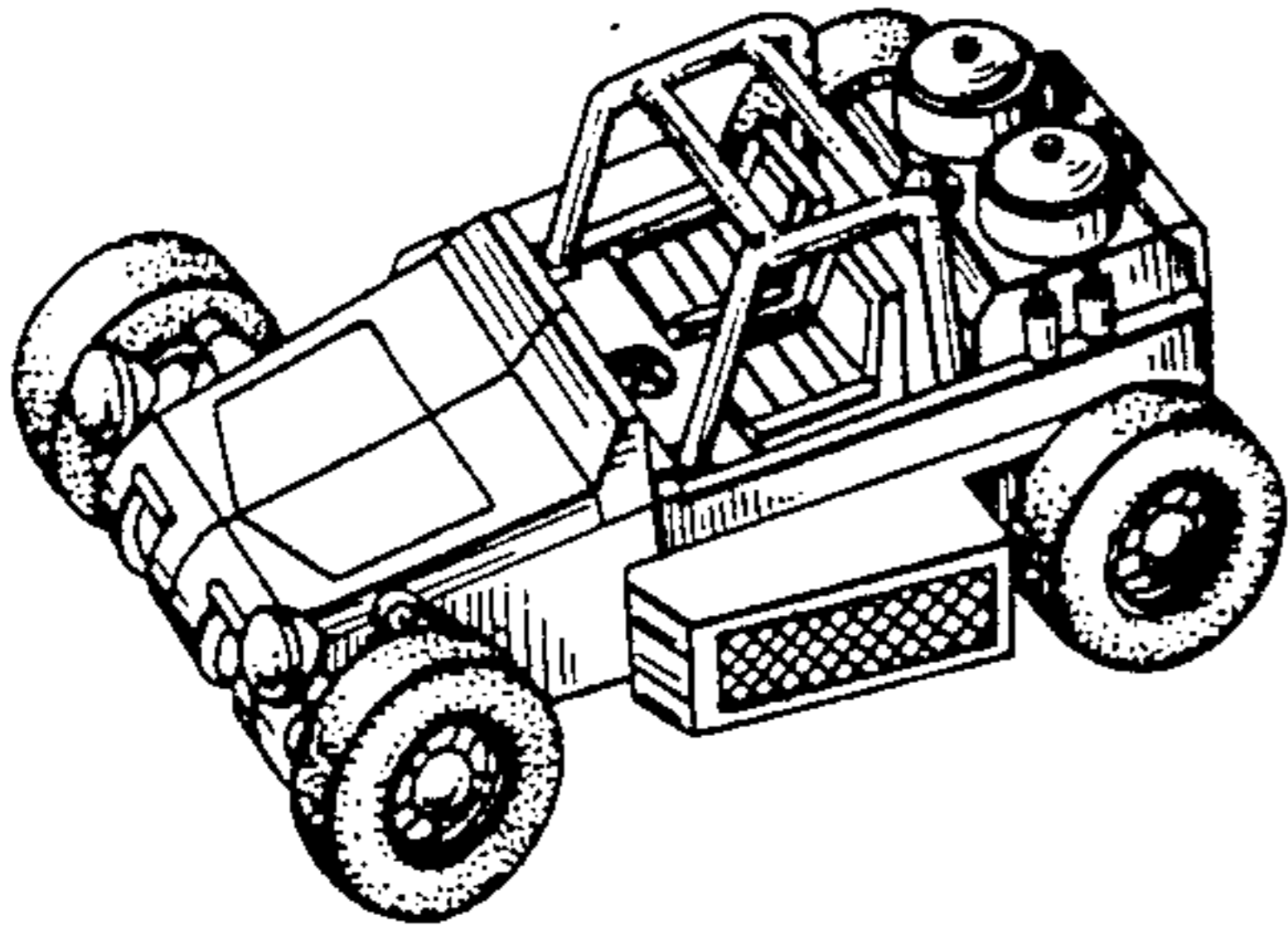

FIG. 2

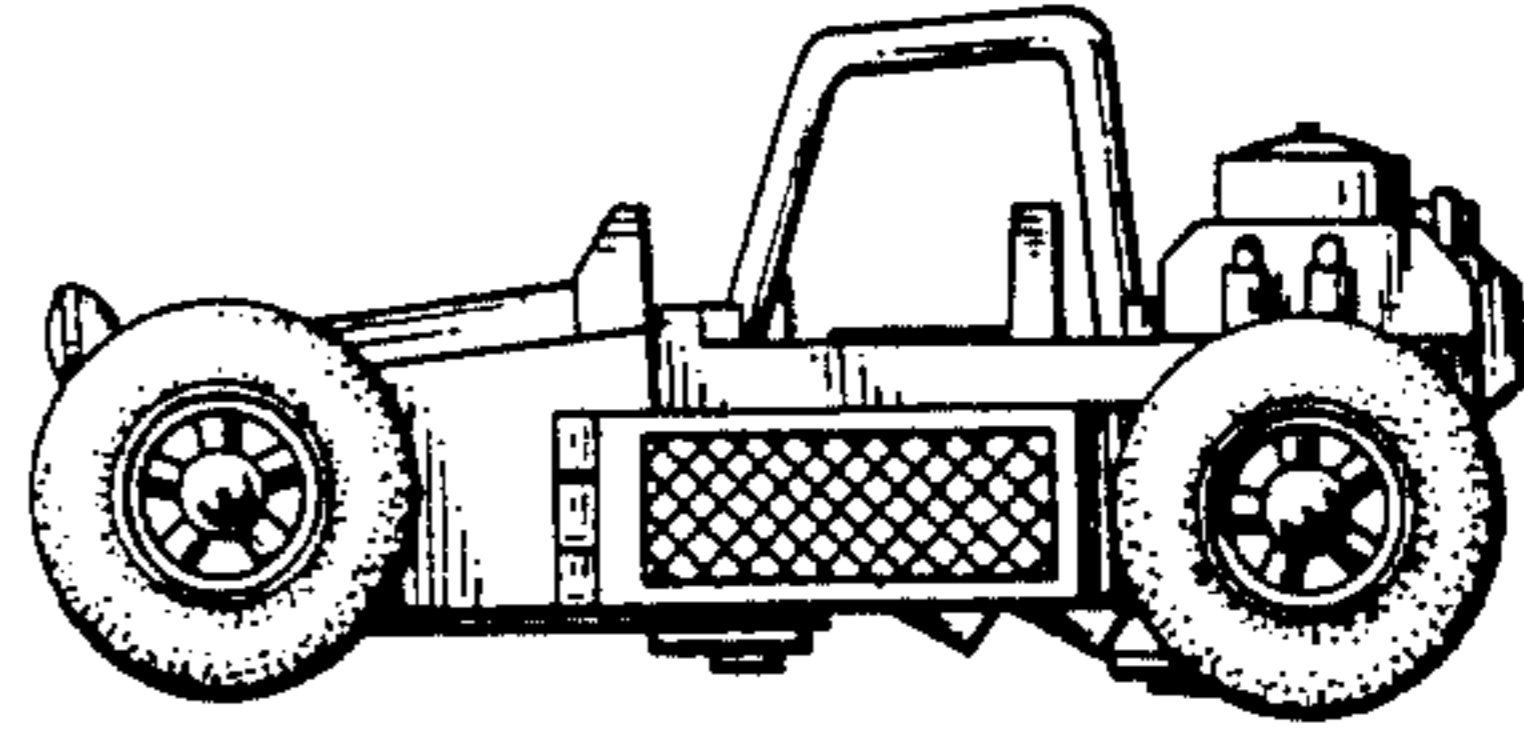

FIG. 3

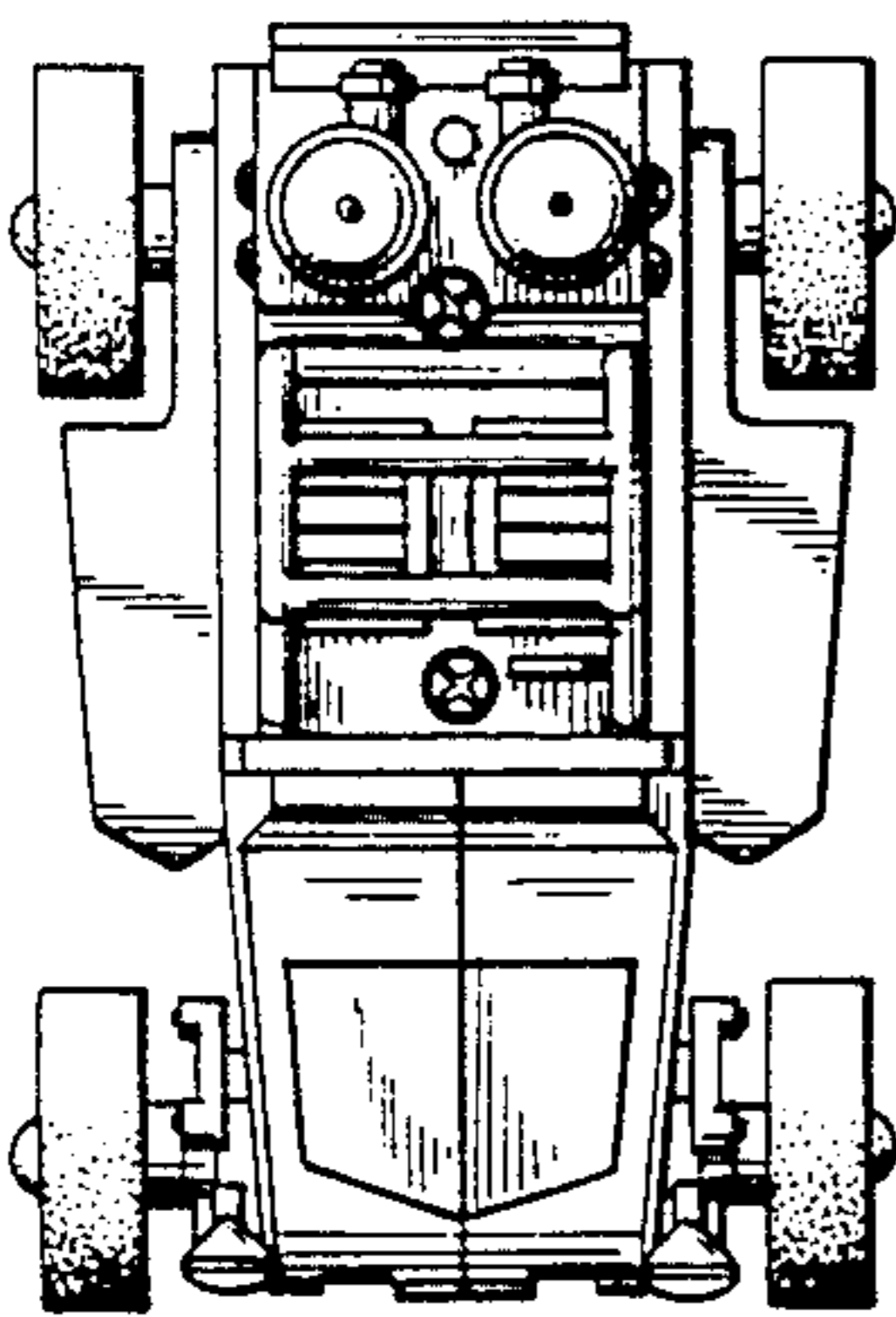

FIG. 4

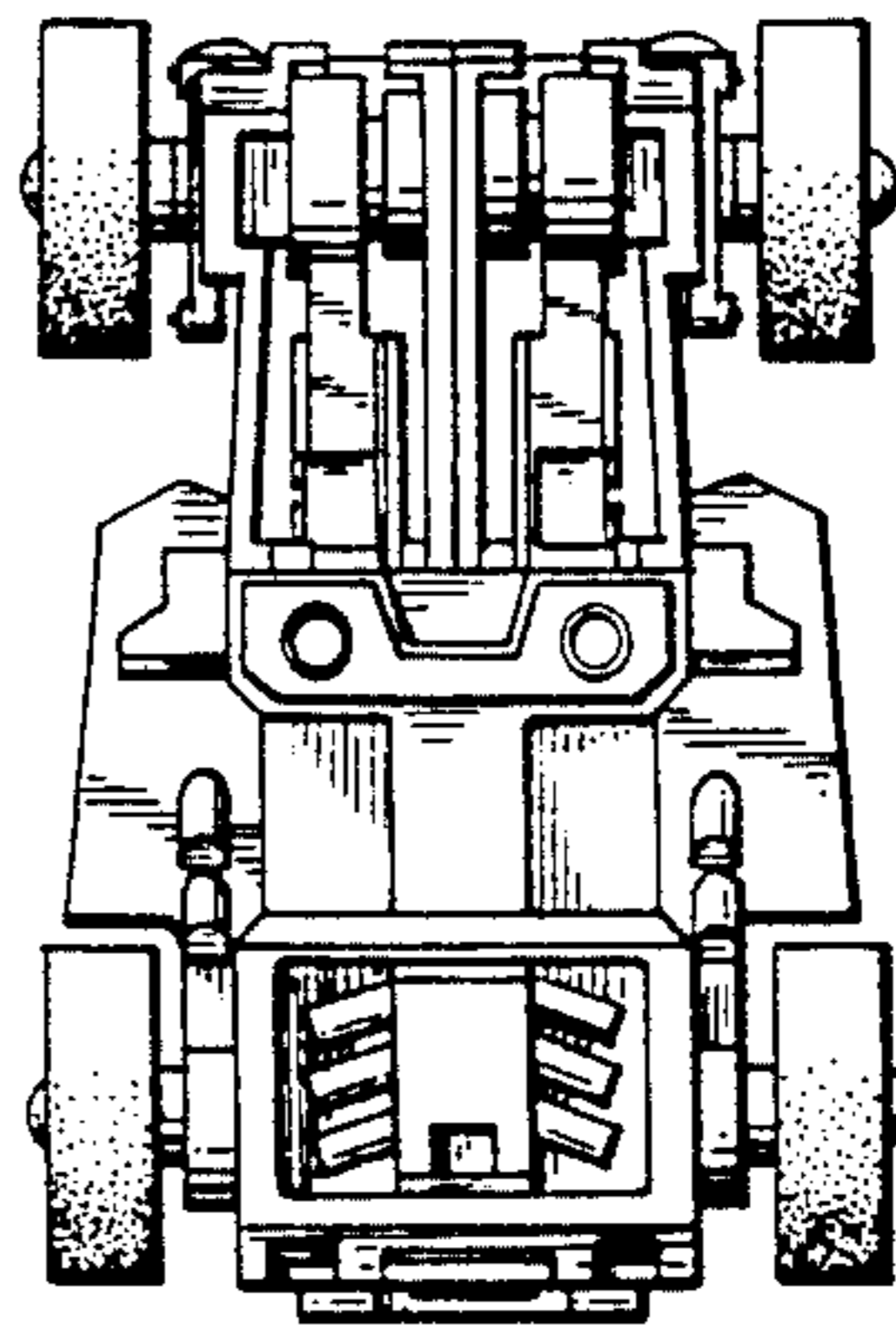

FIG. 5

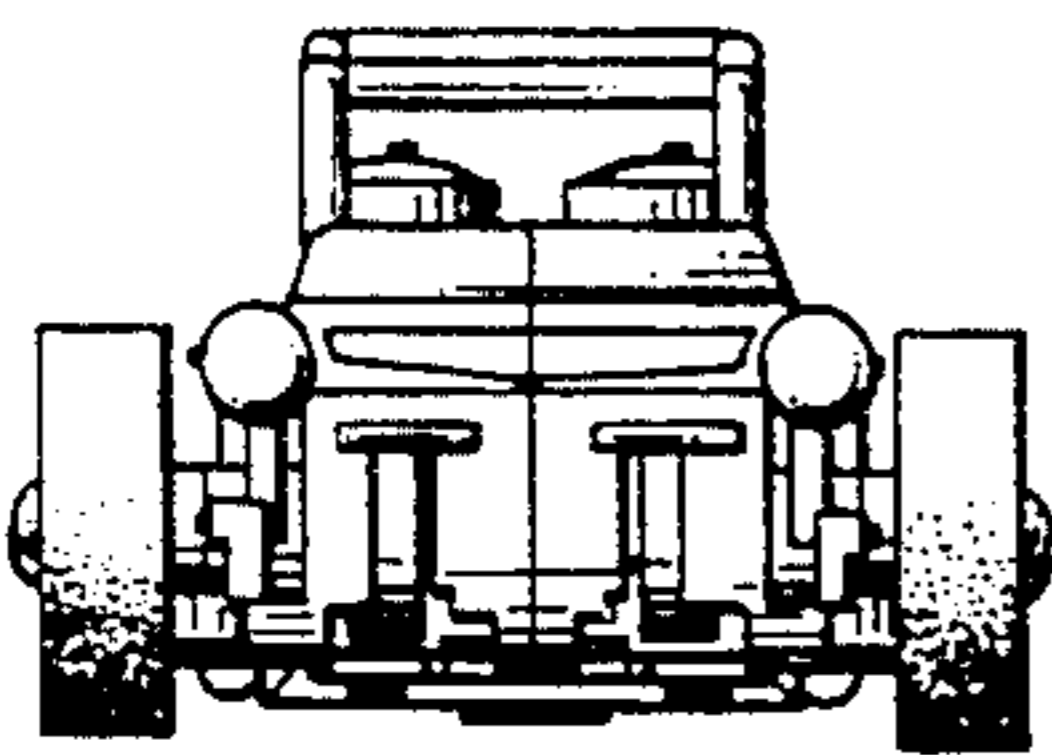

FIG. 6

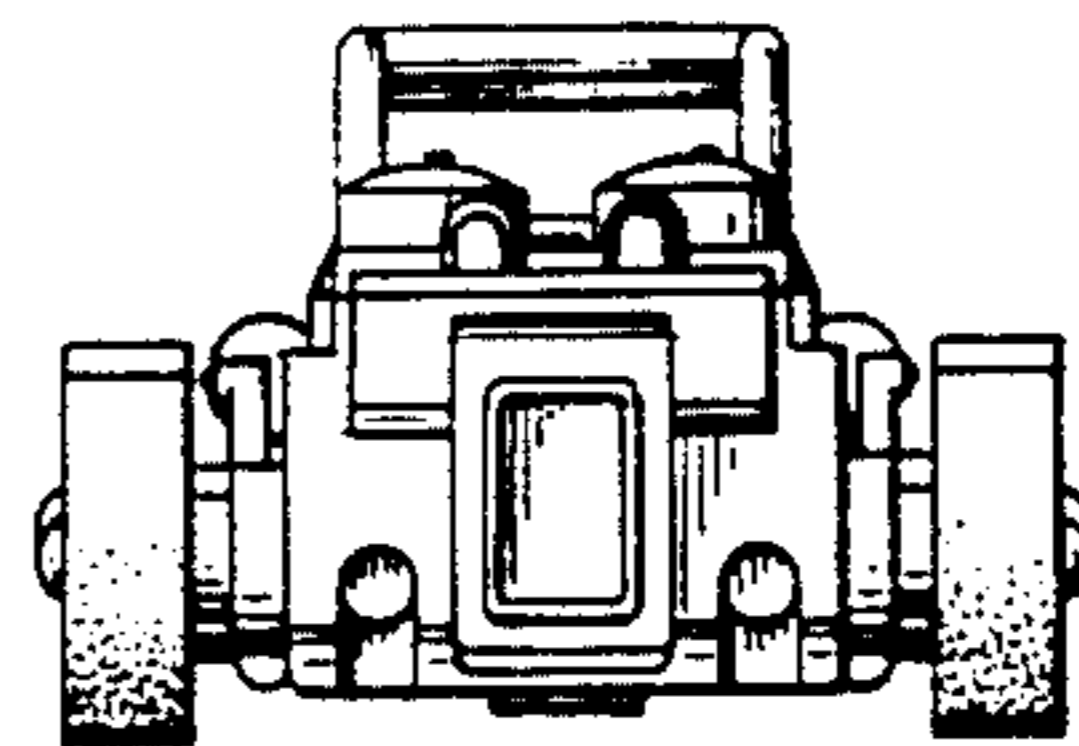

FIG. 7

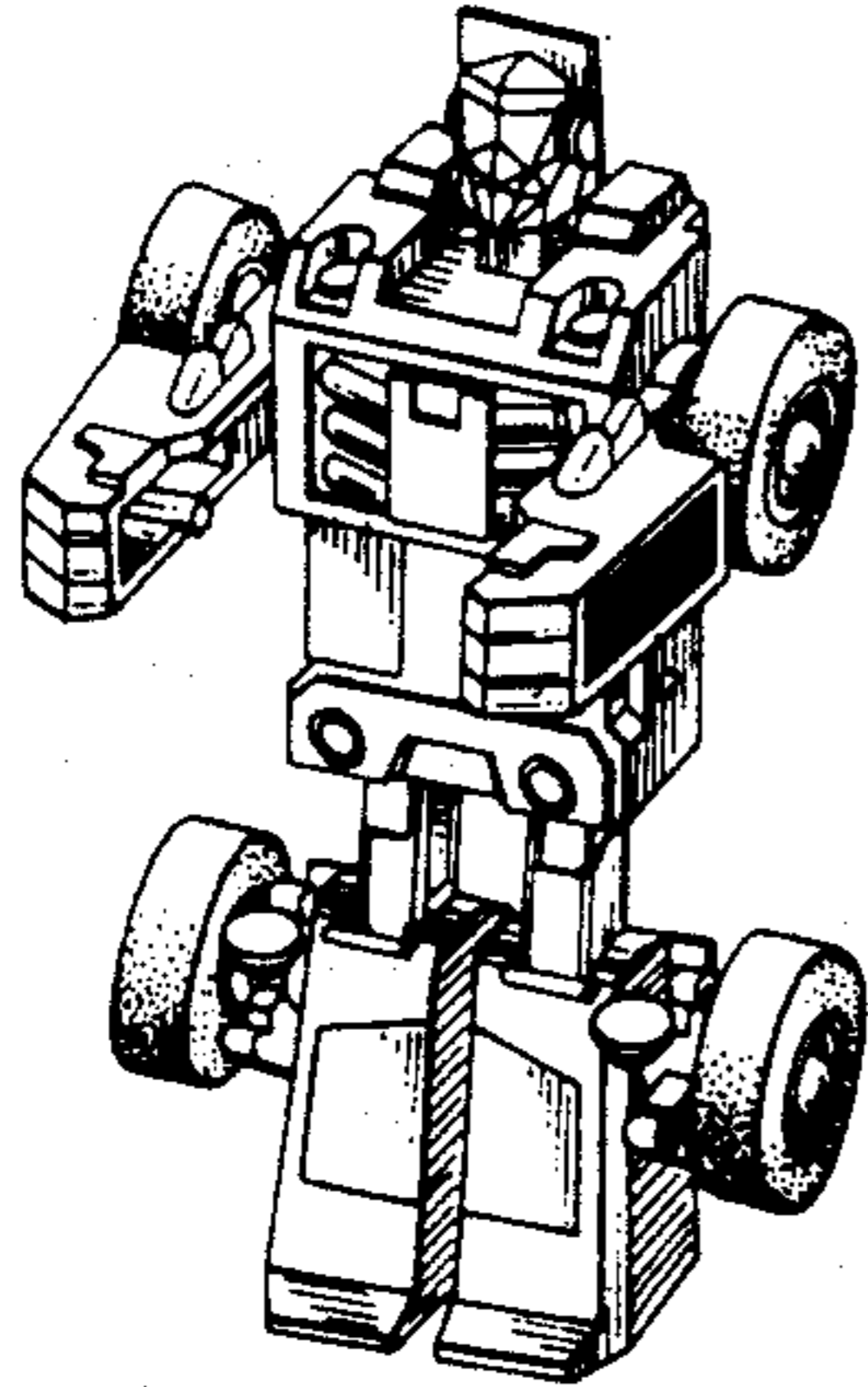

FIG. 8

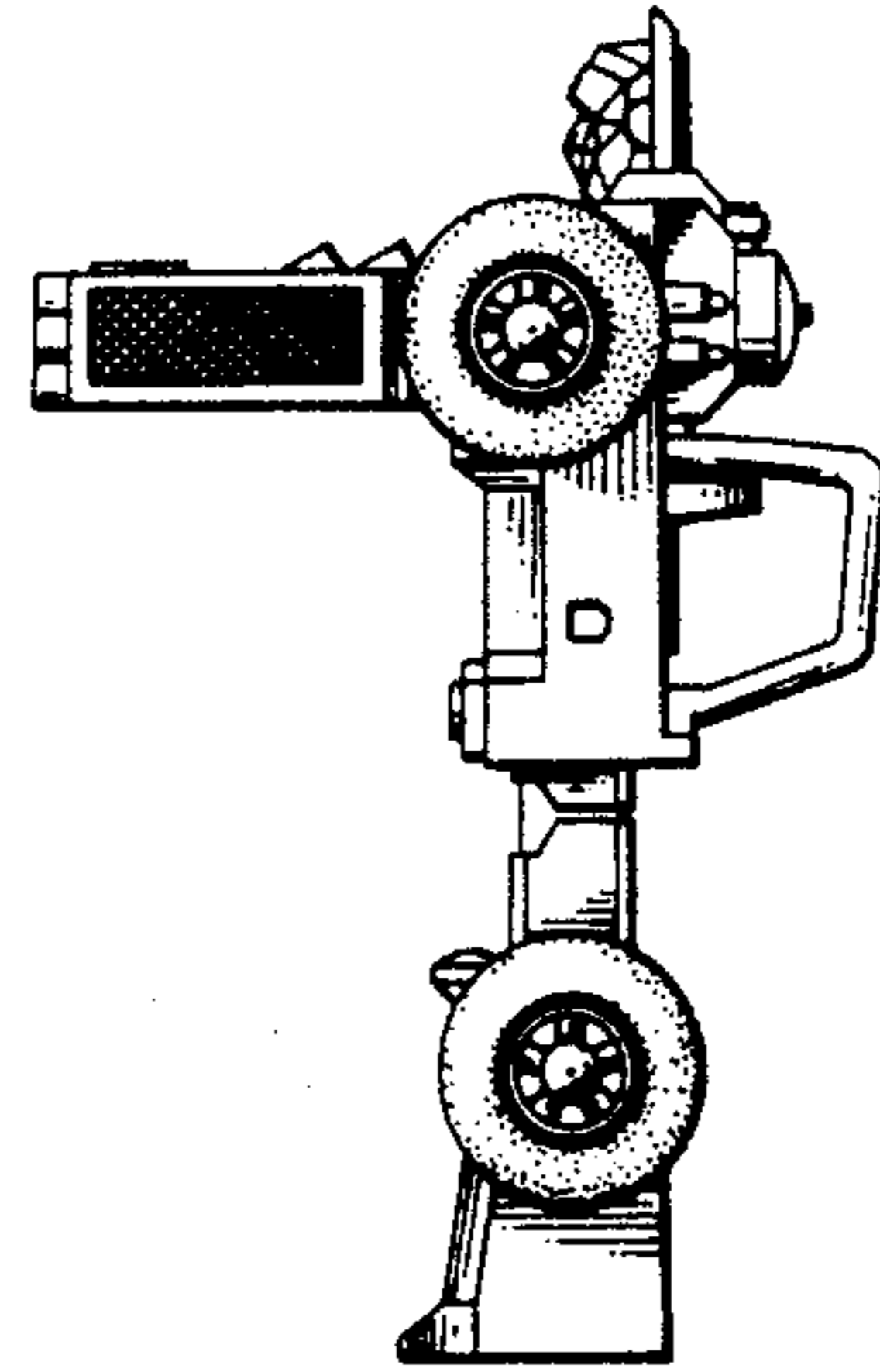

FIG. 9

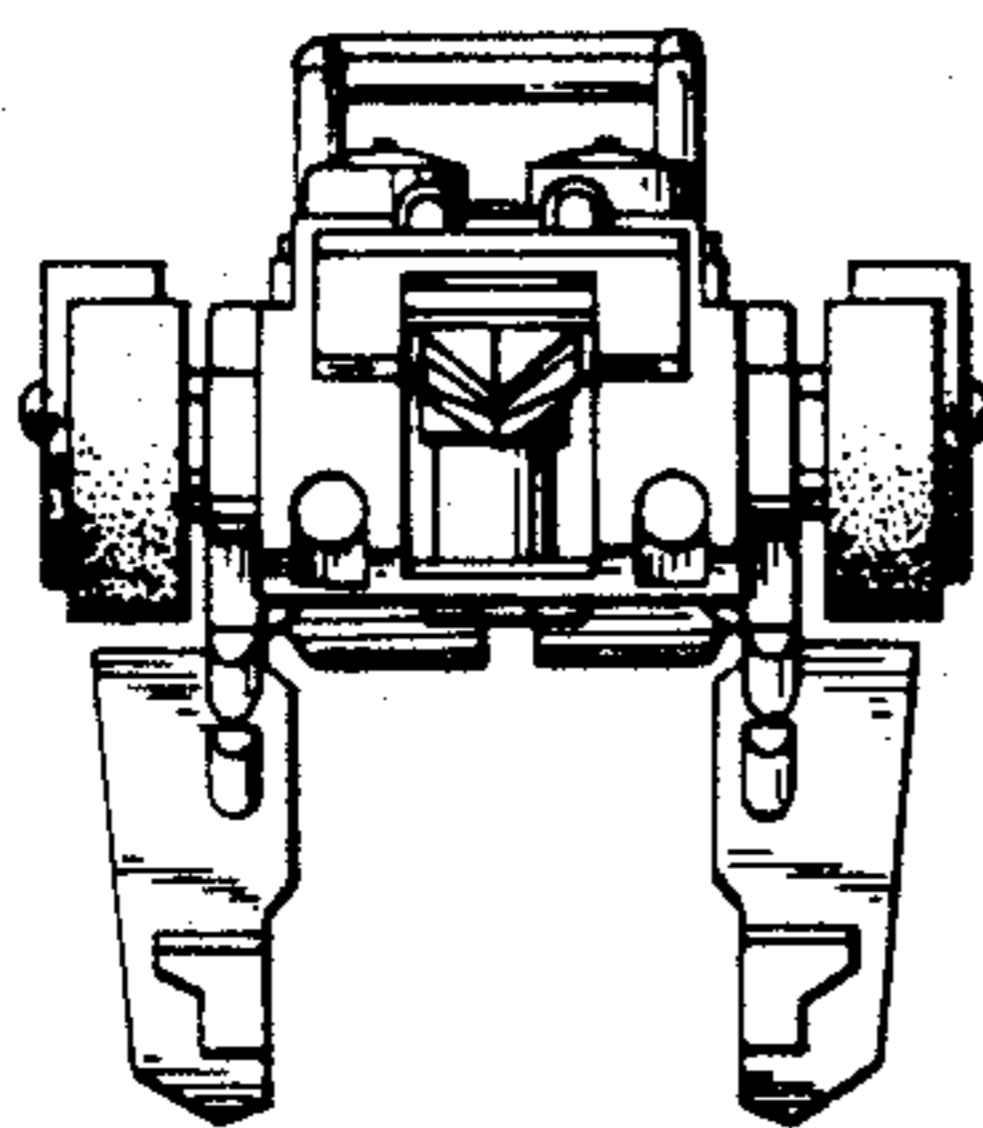

FIG. 10

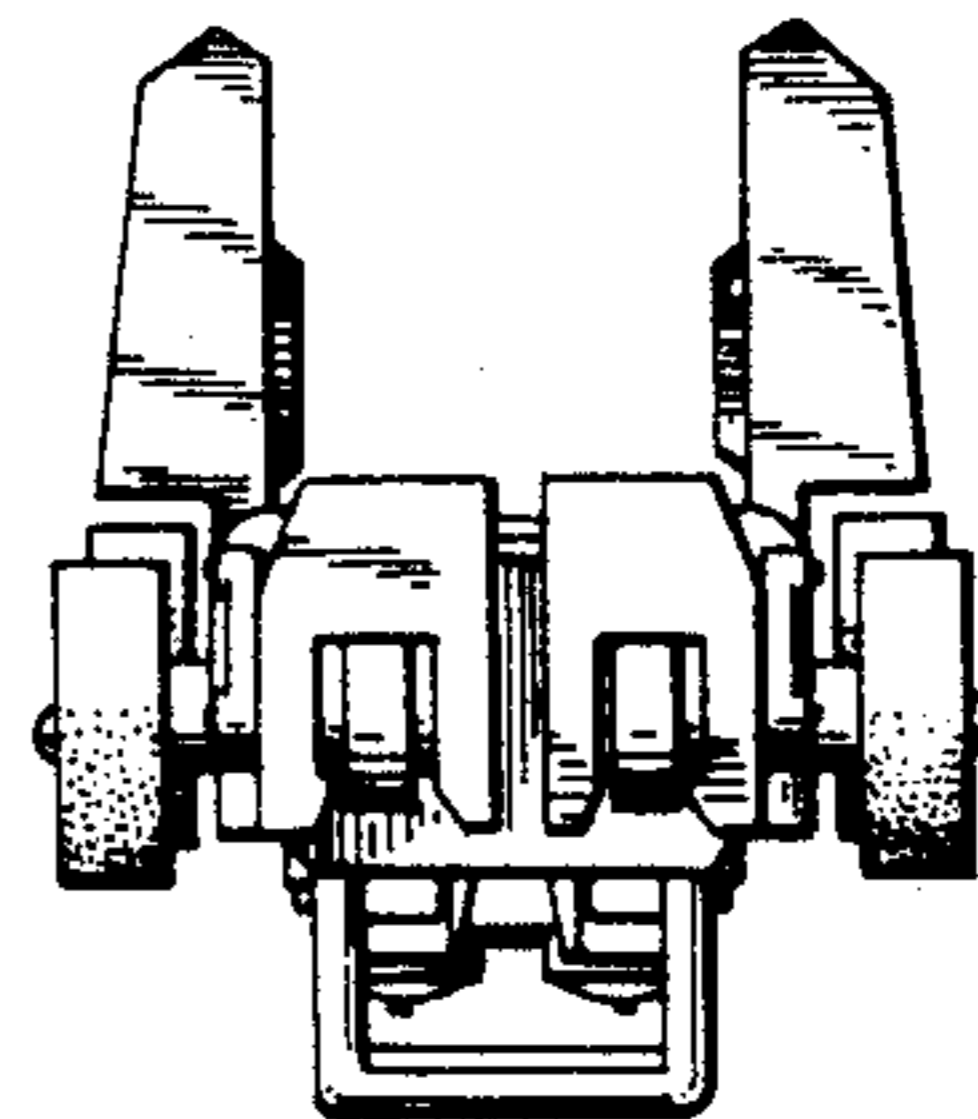

FIG. 11

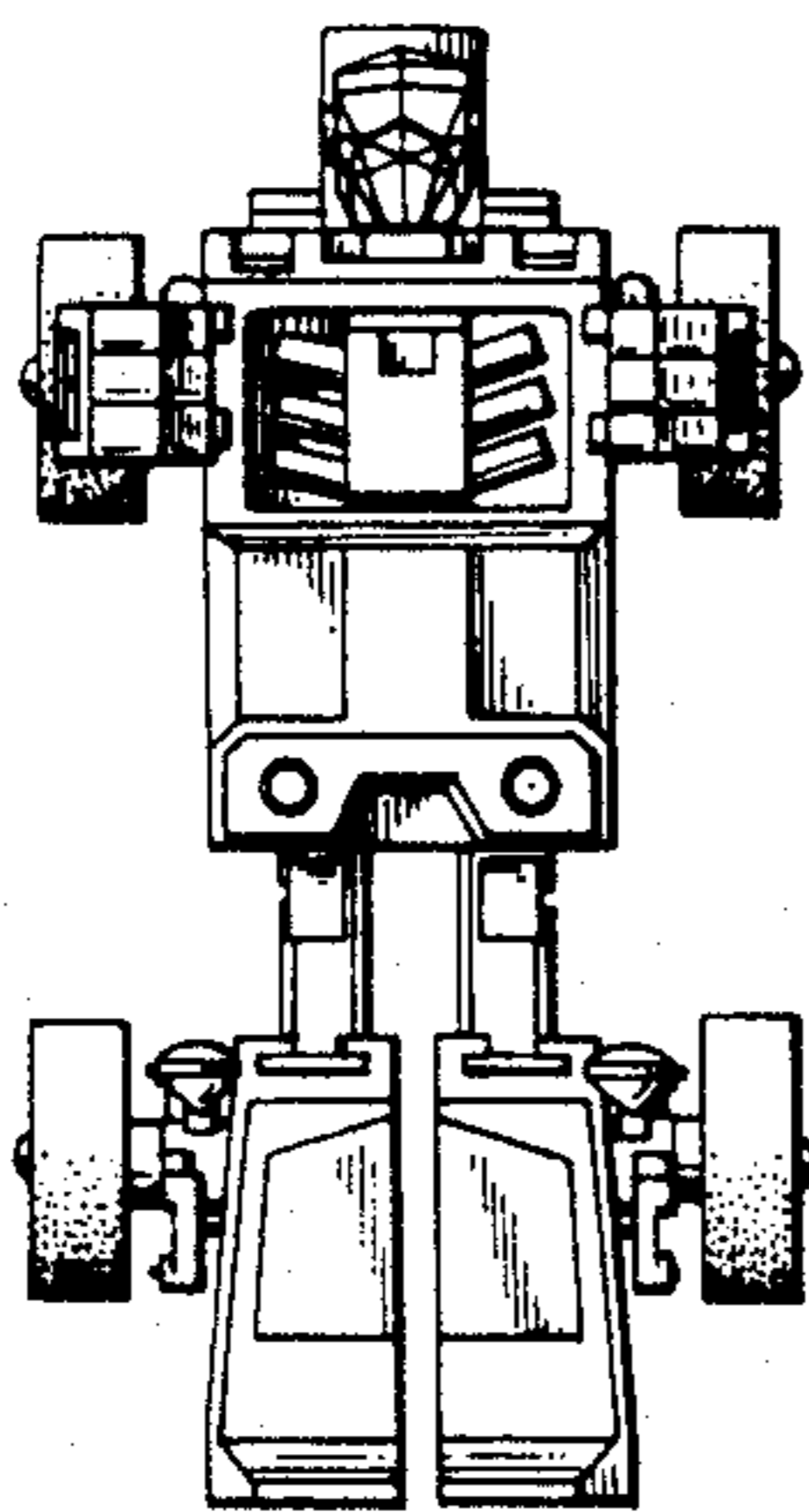

FIG. 12

