

[54] FRONT BUMPER FOR AN AUTOMOBILE

[75] Inventor: Tokuo Fukuichi, Toyota, Japan

[73] Assignee: Toyota Jidosha Kabushiki Kaisha, Toyota, Japan

[**] Term: 14 Years

[21] Appl. No.: 762,538

[22] Filed: Aug. 5, 1985

[52] U.S. Cl. D12/169

[58] Field of Search D12/169, 181; 293/112, 293/102, 113, 120, 121; 296/1.5

[56] References Cited

U.S. PATENT DOCUMENTS

- D. 248,156 6/1978 Tixier D12/169
- D. 274,508 7/1984 Yamashita D12/169

OTHER PUBLICATIONS

Motor Trend, 11/84, p. 17, Front Bumper & Spoiler of Mercedes Benz, top right side of page.

Primary Examiner—James M. Gandy
Attorney, Agent, or Firm—Cushman, Darby & Cushman

[57] CLAIM

The ornamental design for a front bumper for an automobile, as shown.

DESCRIPTION

FIG. 1 is a perspective view of a front bumper for an automobile showing my new design;
 FIG. 2 is a front elevational view;
 FIG. 3 is a rear elevational view;
 FIG. 4 is a top plan view;
 FIG. 5 is a bottom plan view;
 FIG. 6 is a left side elevational view;
 FIG. 7 is a right side elevational view; and
 FIG. 8 is a cross sectional view taken along line VIII-VIII in FIG. 2.

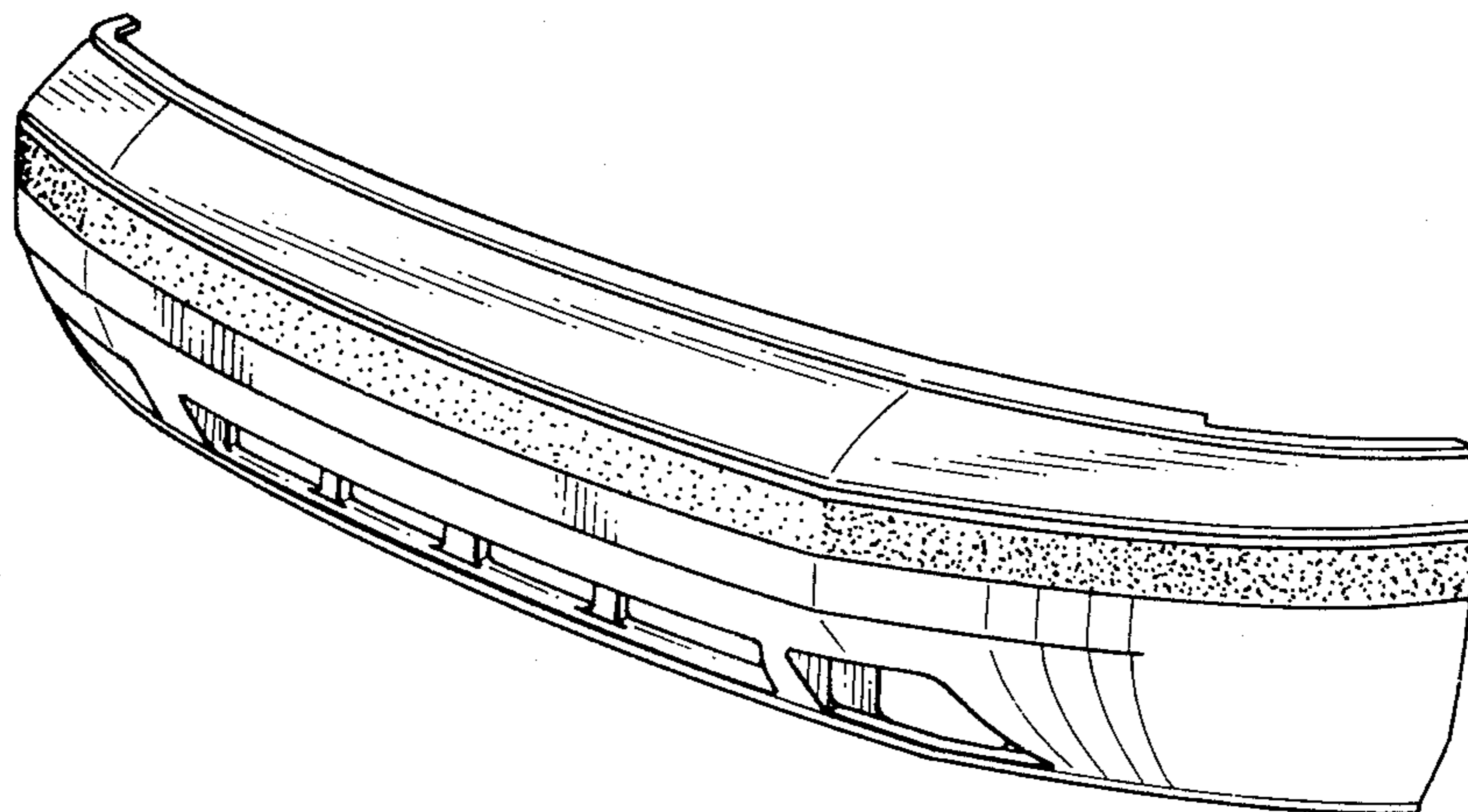

Fig. 1

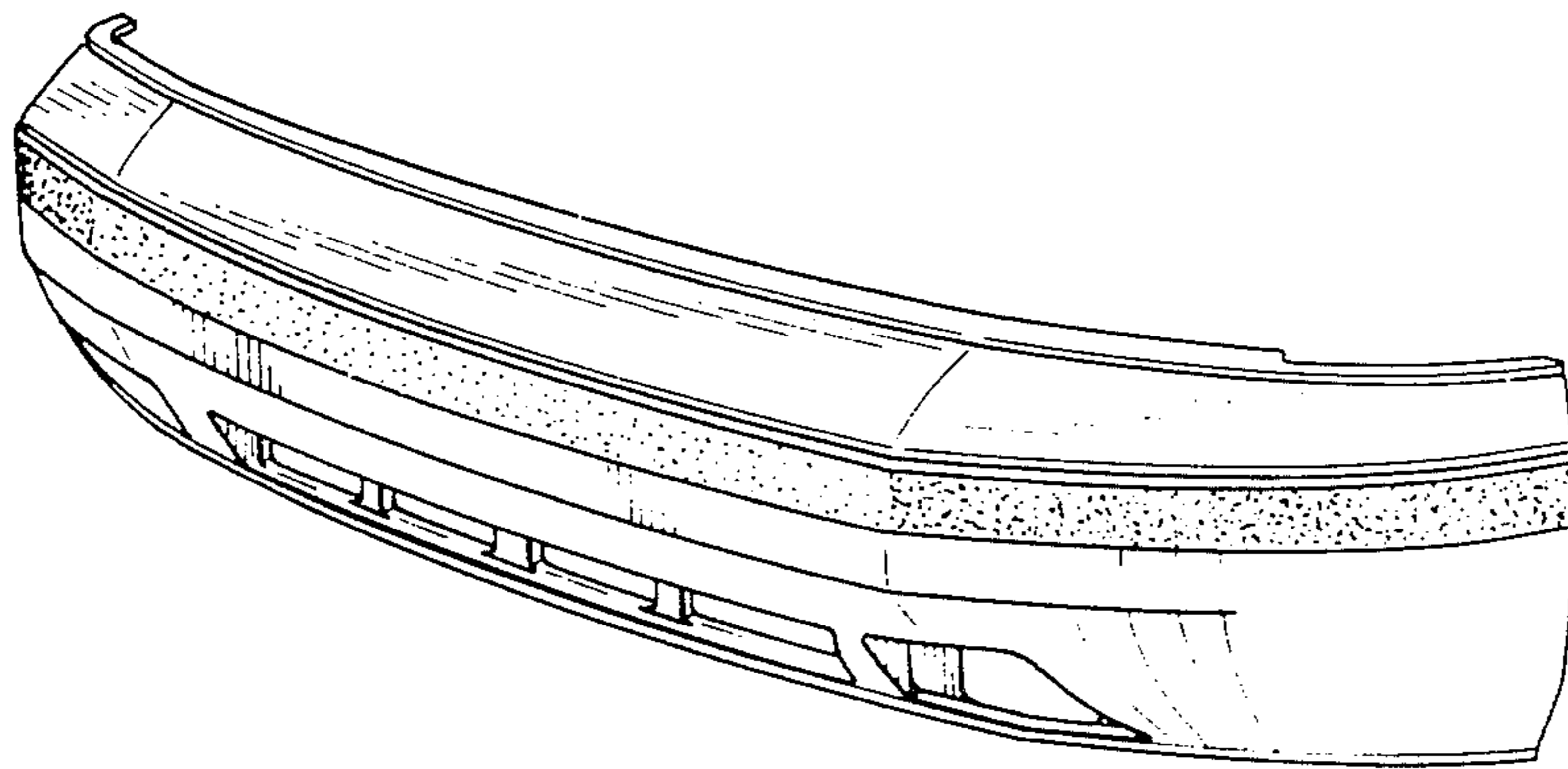

Fig. 2

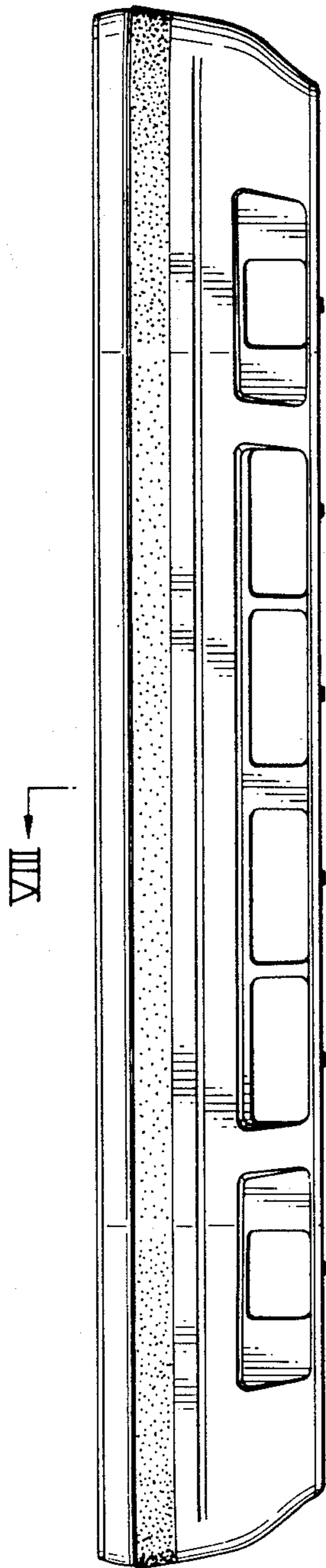

Fig. 3

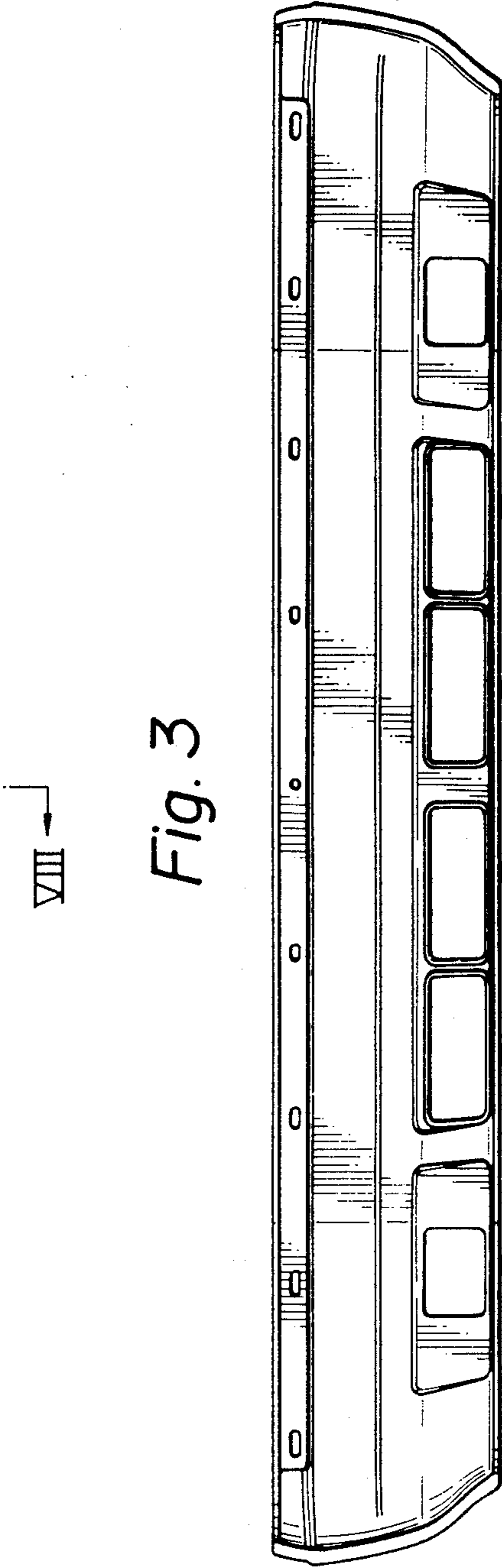

Fig. 4

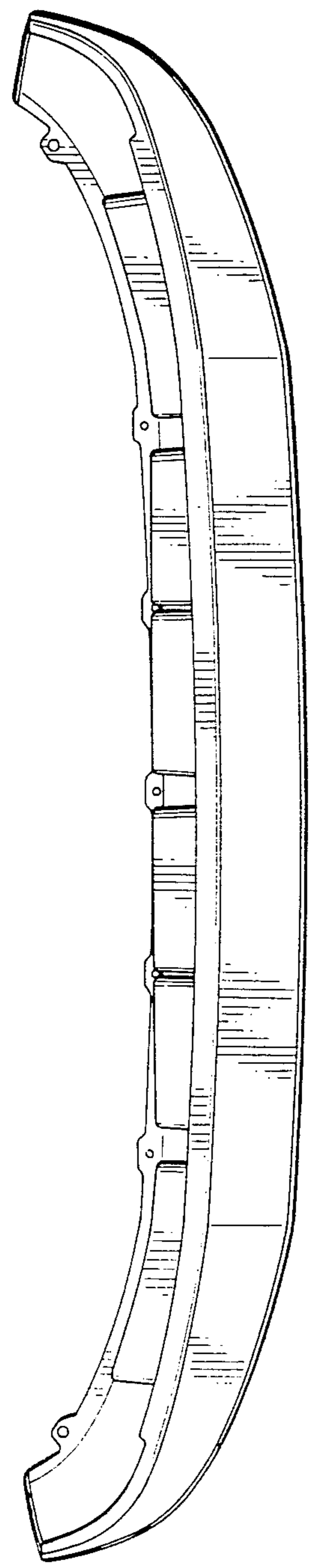

Fig. 5

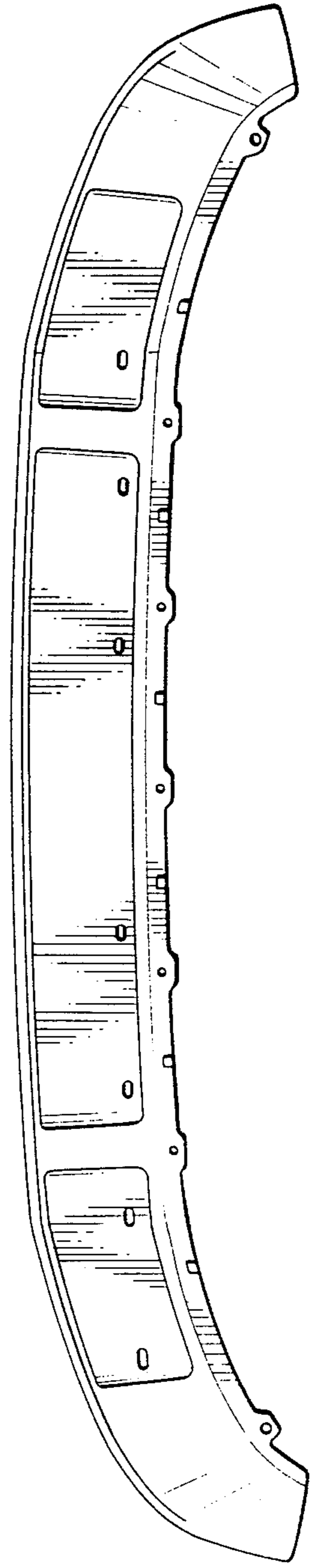

Fig. 6

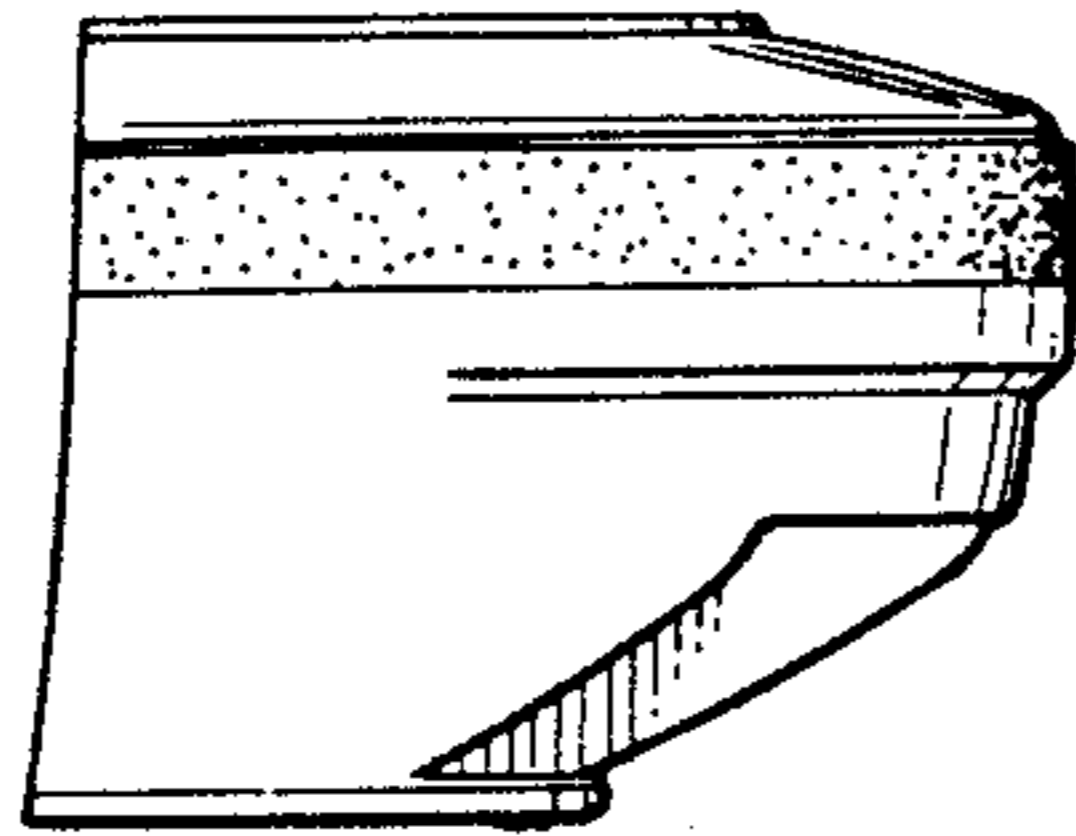

Fig. 7

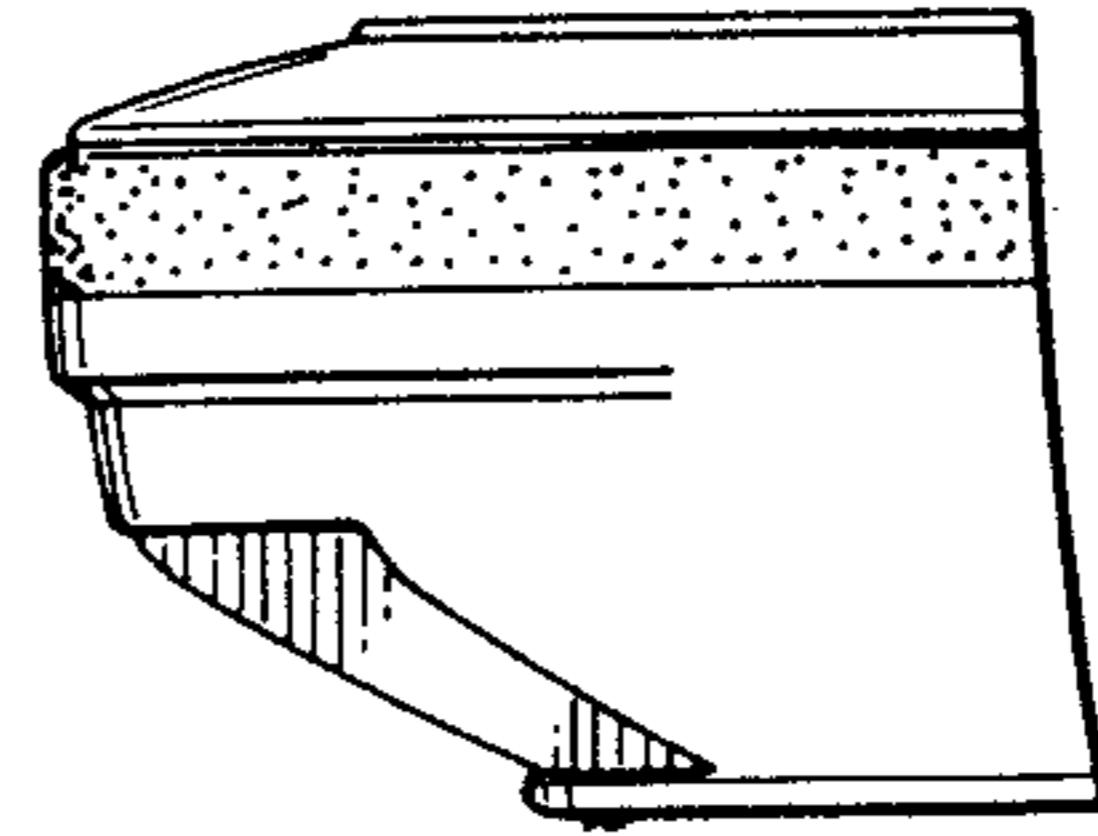

Fig. 8

