

[54] HELICOPTER

[76] Inventor: Buford J. Schramm, 1330 E. Fremont Dr., Tempe, Ariz. 85281

[**] Term: 14 Years

[21] Appl. No.: 630,025

[22] Filed: Jul. 12, 1984

[52] U.S. Cl. D12/327

[58] Field of Search D12/326, 327, 339; 244/17.11, 17.19; 446/232

[56] References Cited

U.S. PATENT DOCUMENTS

D. 206,734 1/1967 Kesling D12/327
3,985,318 10/1976 Dominey et al. 244/17.11

OTHER PUBLICATIONS

Flight Int'l. Aug. 1980, p. 678, Rotorway's new Exec Helicopter (top).

Bell Helicopter Textron Inc. Brochure, The Bell Long Ranger II, p. 1 (front).

Primary Examiner—James M. Gandy
Assistant Examiner—Kay H. Chin
Attorney, Agent, or Firm—Donald D. Mon

[57] CLAIM

The ornamental design for a helicopter, as shown and described.

DESCRIPTION

FIG. 1 is a right side elevation view of a helicopter showing my new design;
FIG. 2 is a top plan view thereof;
FIG. 3 is a rear elevation view thereof;
FIG. 4 is a front elevation view thereof.
The left-hand side elevation of the helicopter is substantially the mirror image of FIG. 1, except that the tail rotor is on the left-hand side, and the anti-torque vane is on the right-hand side, and the views would differ accordingly.

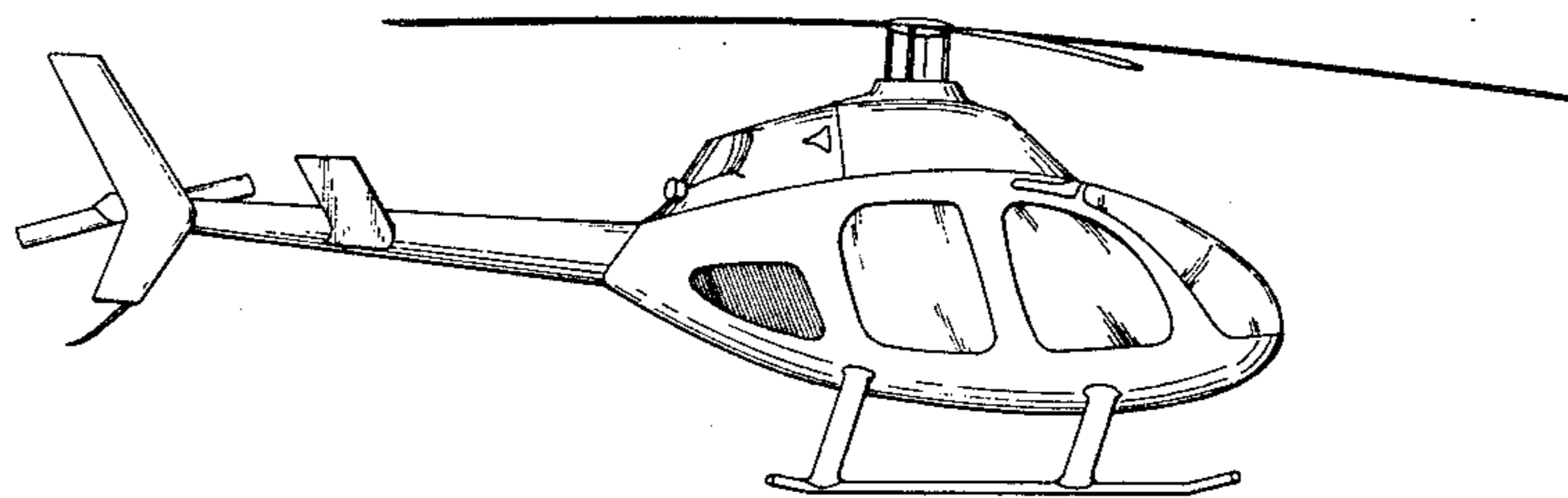
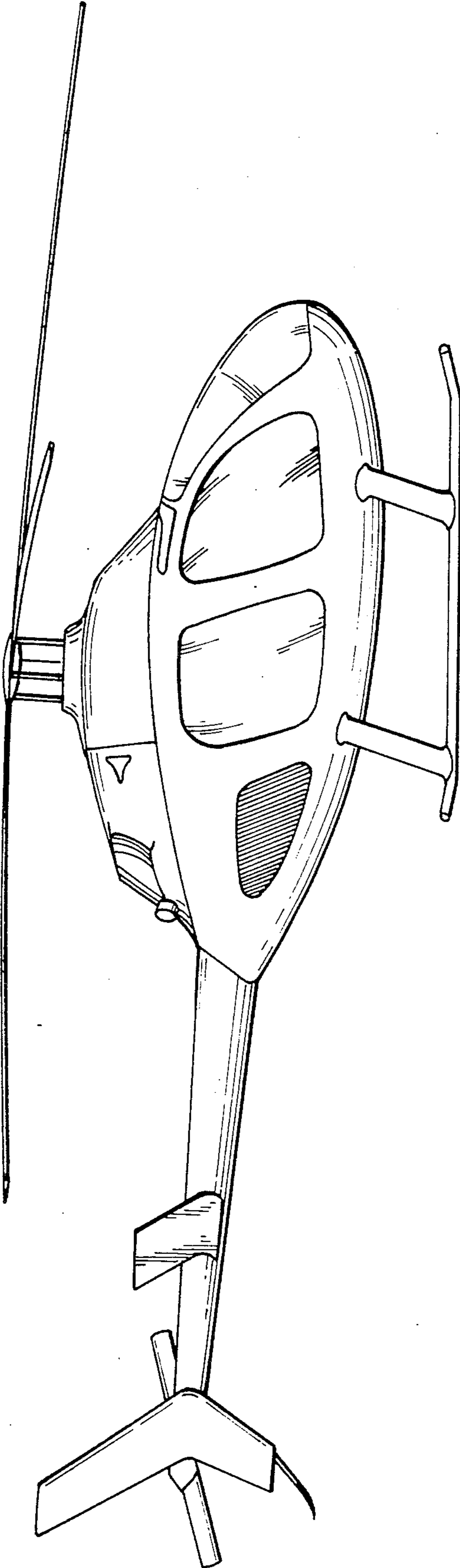

FIG. 1



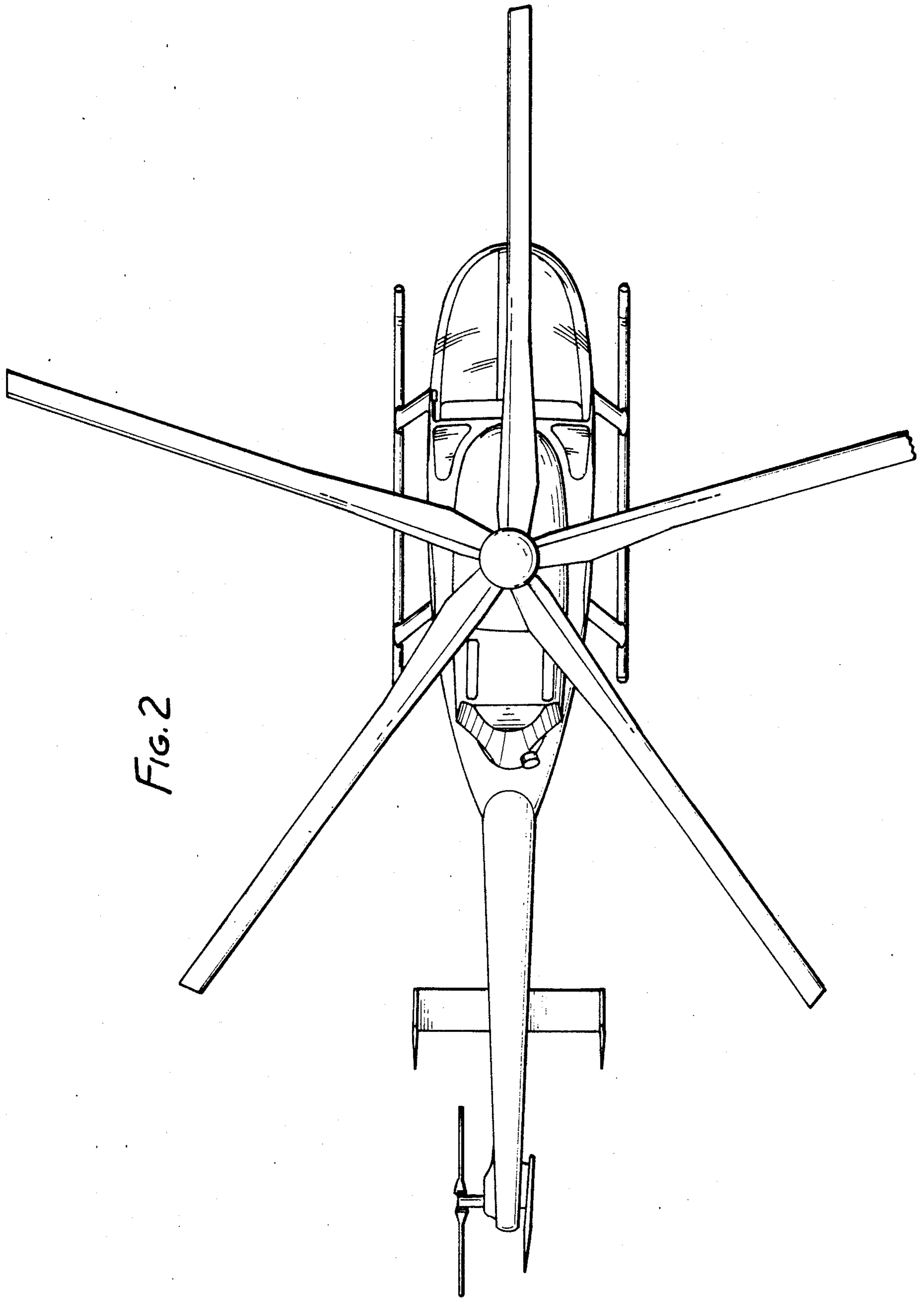

FIG. 2

FIG. 3

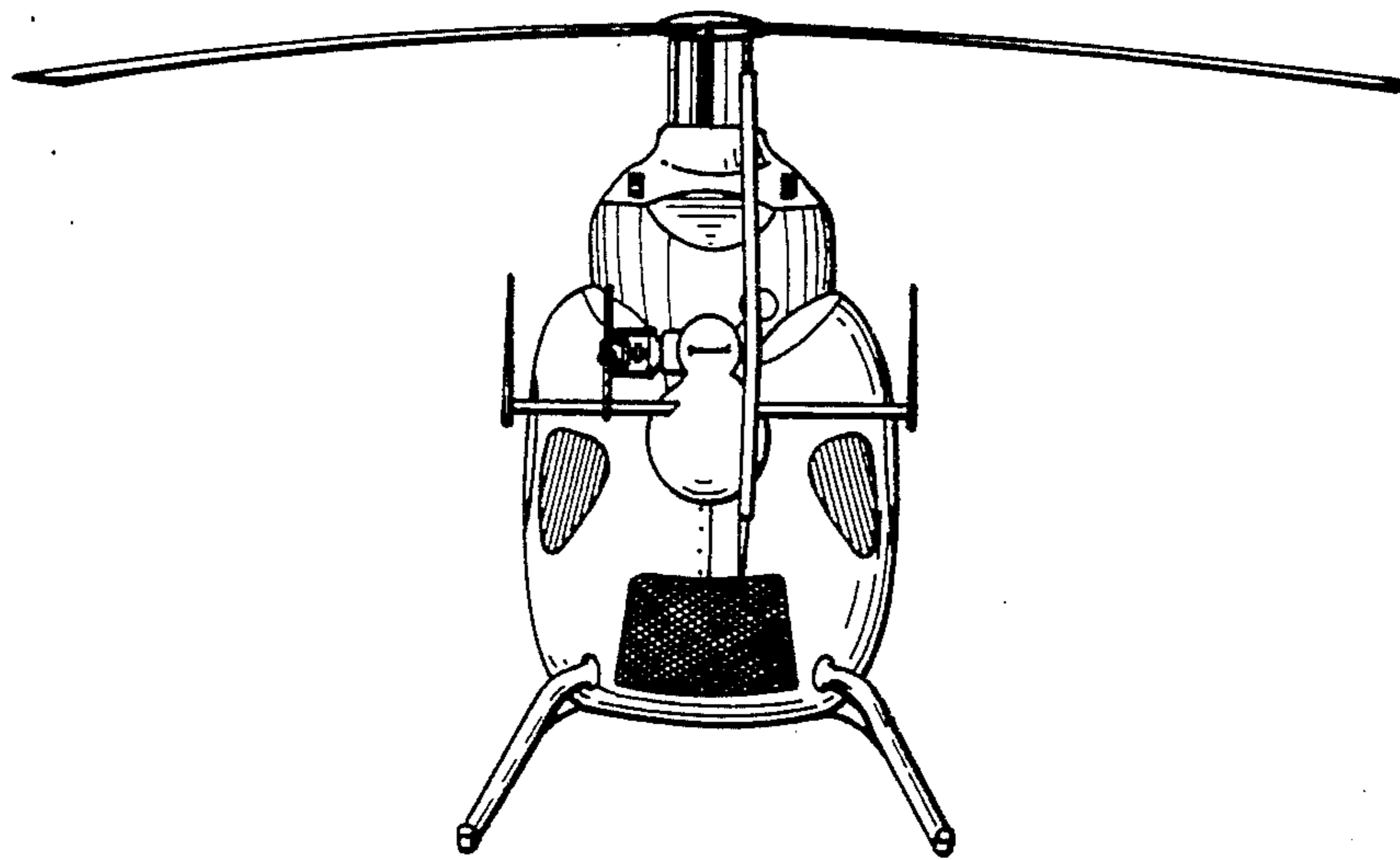

FIG. 4

