

[54] WASTE TRANSFER TRAILER

[75] Inventor: Kosti Shirvanian, Los Angeles, Calif.

[73] Assignee: Western Waste Industries, Carson, Calif.

[**] Term: 14 Years

[21] Appl. No.: 597,021

[22] Filed: Apr. 5, 1984

[52] U.S. Cl. D12/15

[58] Field of Search D12/15; D34/3; 100/229 A, 229 R; D15/123

[56] References Cited

U.S. PATENT DOCUMENTS

- D. 238,259 12/1975 Sweet D12/15
- D. 258,442 3/1981 Schmidt D12/15
- D. 263,174 2/1982 Bettencourt et al. D34/3

OTHER PUBLICATIONS

Automotive News, May 2, 1960, p. 43, Hercules Aluminum Dump Trailers.

Primary Examiner—James M. Gandy
Assistant Examiner—Kay H. Chin
Attorney, Agent, or Firm—Noel F. Heal

[57] CLAIM

The ornamental design for a waste transfer trailer, as shown and described.

DESCRIPTION

FIG. 1 is a perspective view of a waste transfer trailer showing my new design;
FIG. 2 is a left side elevation view thereof;
FIG. 3 is a front elevation view thereof;
FIG. 4 is a rear elevation view thereof;
FIG. 5 is a top plan view thereof;
FIG. 6 is a bottom plan view thereof;
FIG. 7 is a right side elevation view thereof.

The fragmentary criss-cross pattern shown on the top of the trailer in FIGS. 1 and 5 is understood to be continuous throughout the area shown.

The broken lines shown in FIGS. 1, 2, 3, 6 and 7 are for illustrative purposes only.

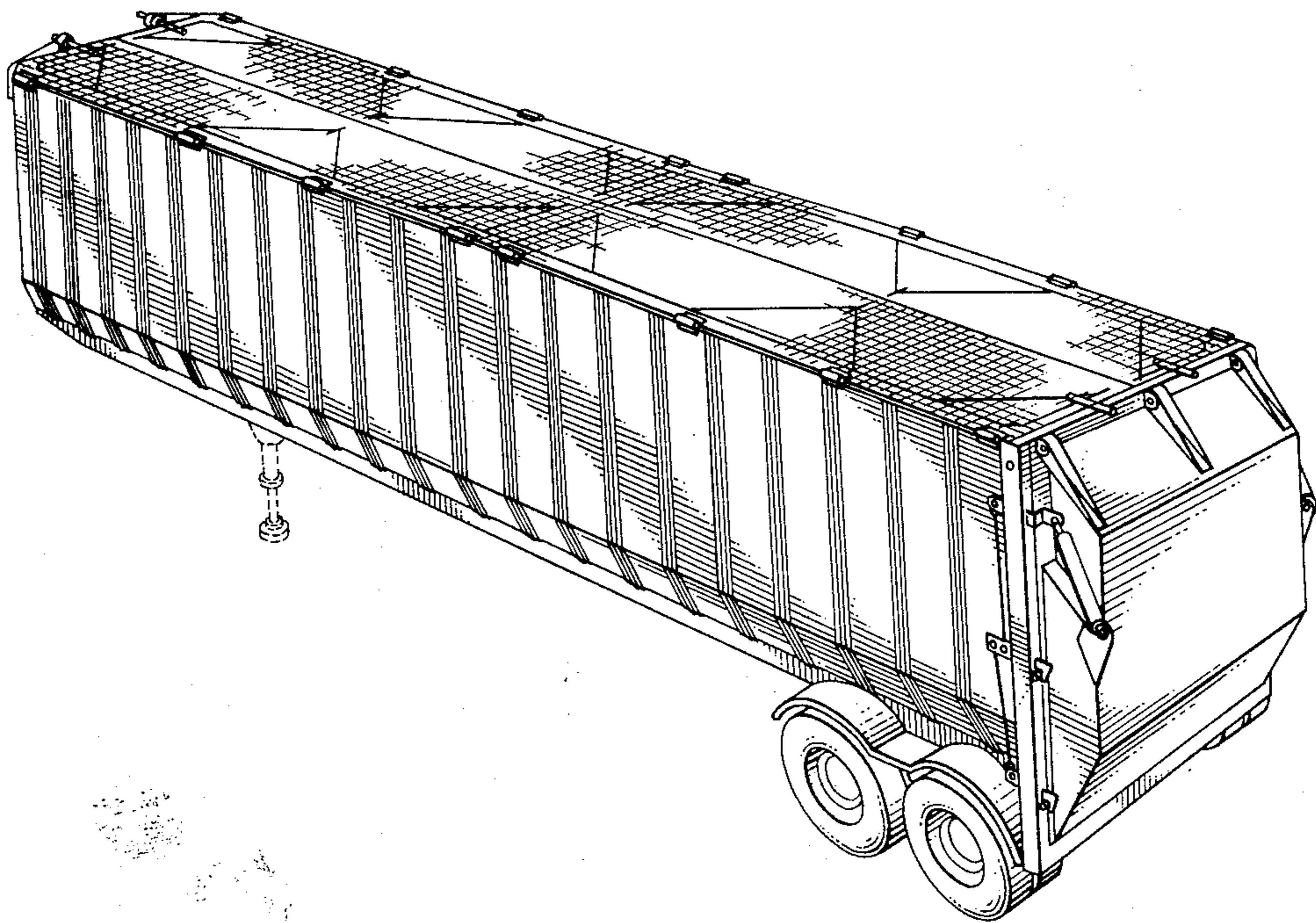

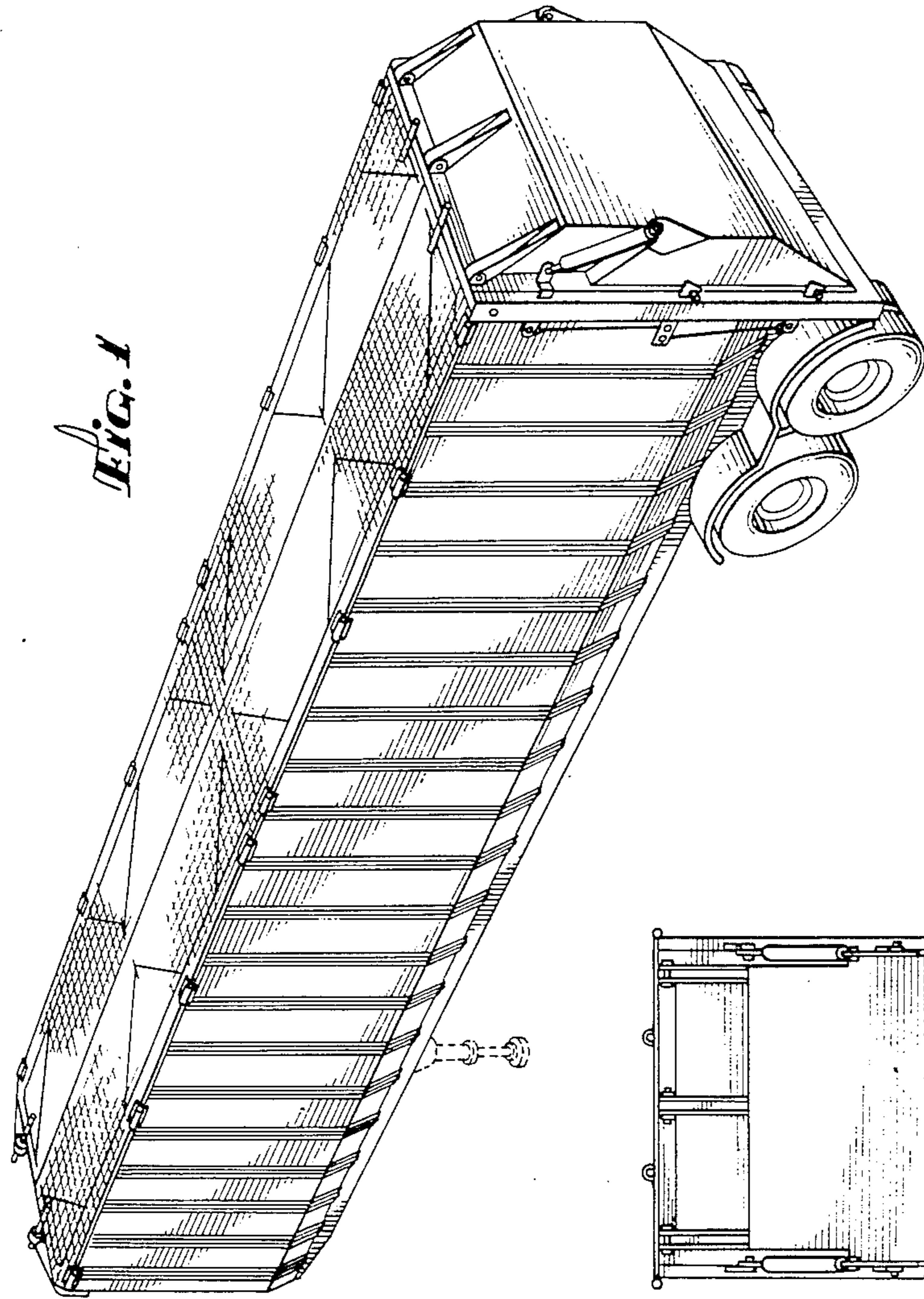

FIG. 1

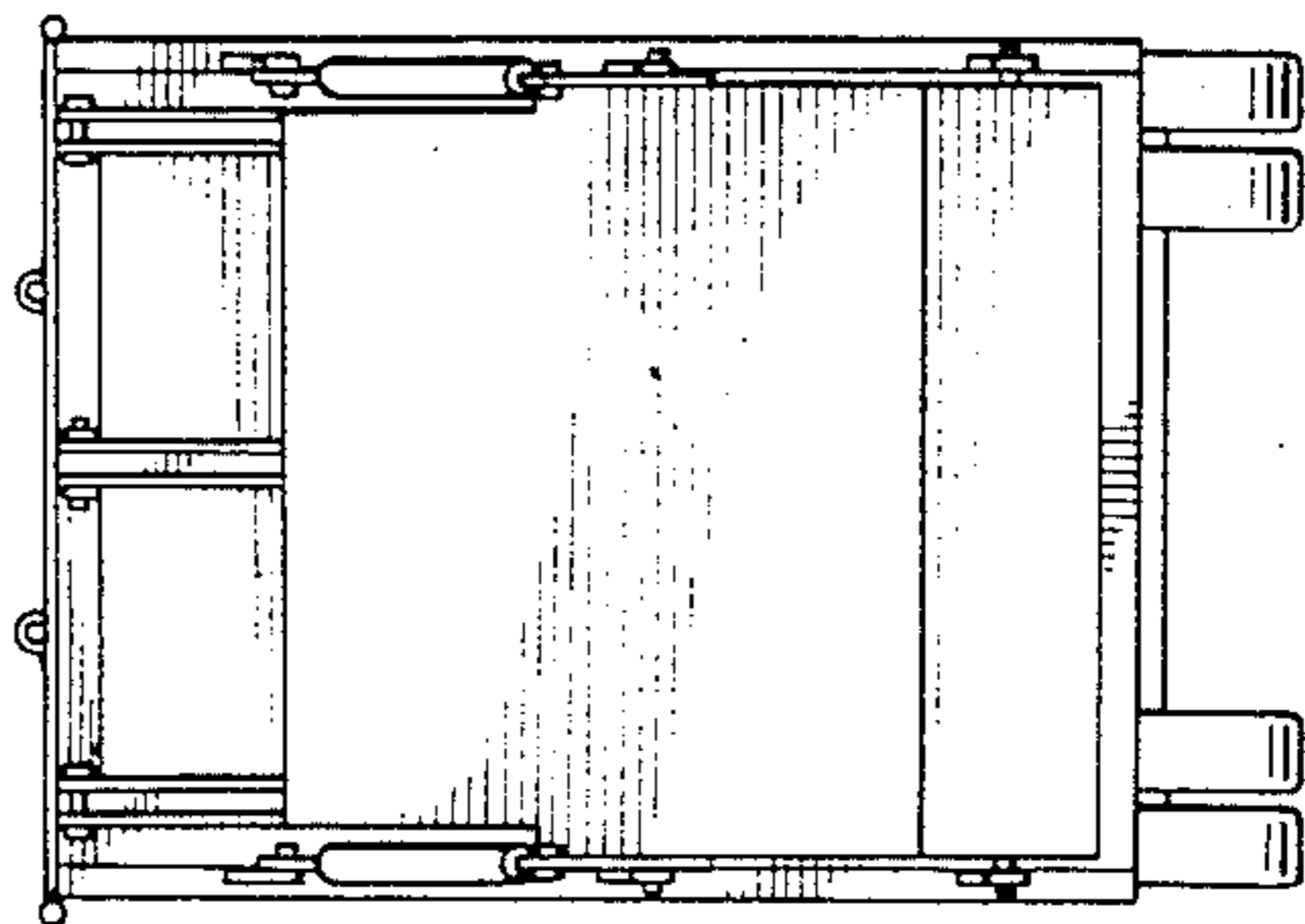

FIG. 4

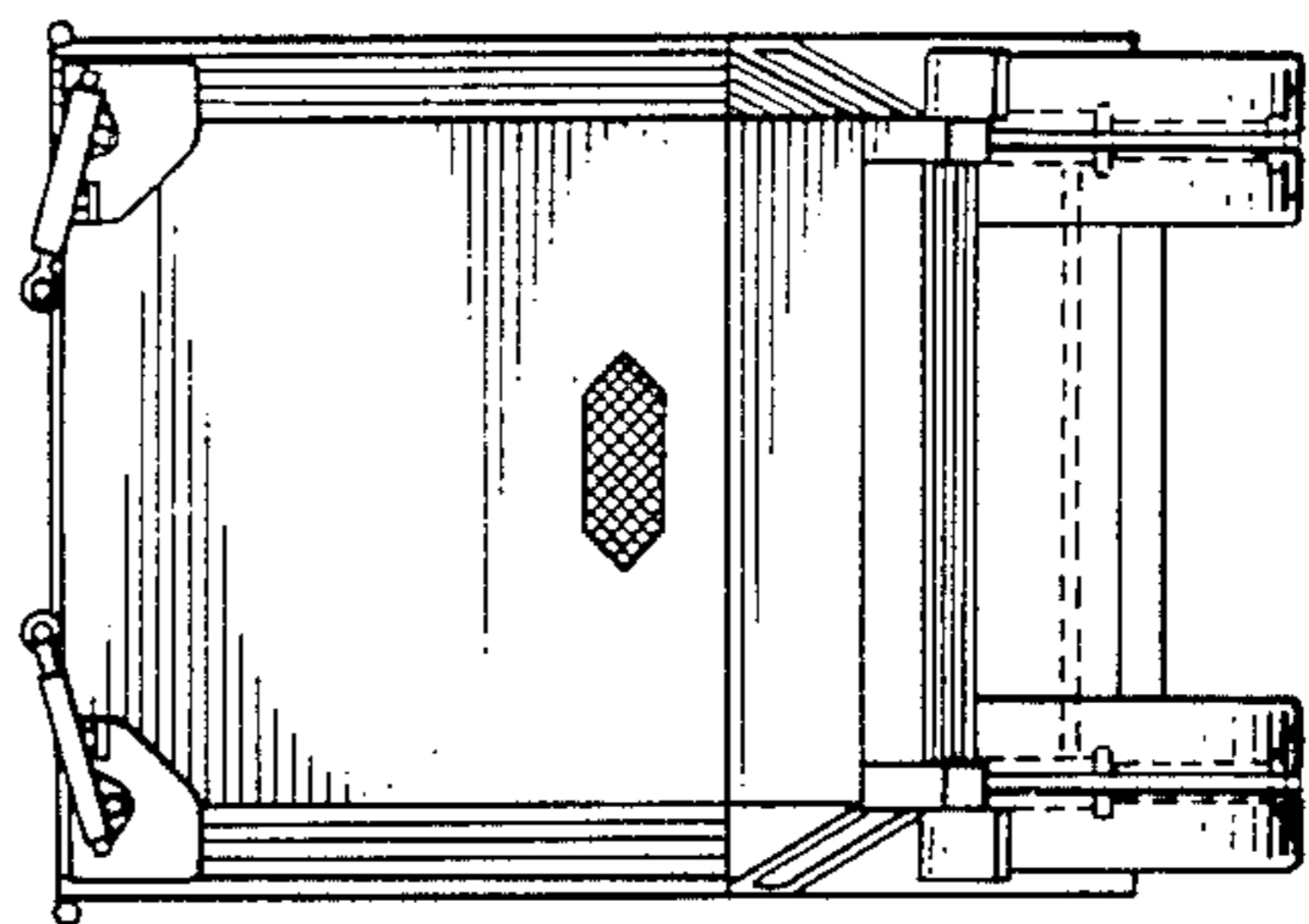

FIG. 3

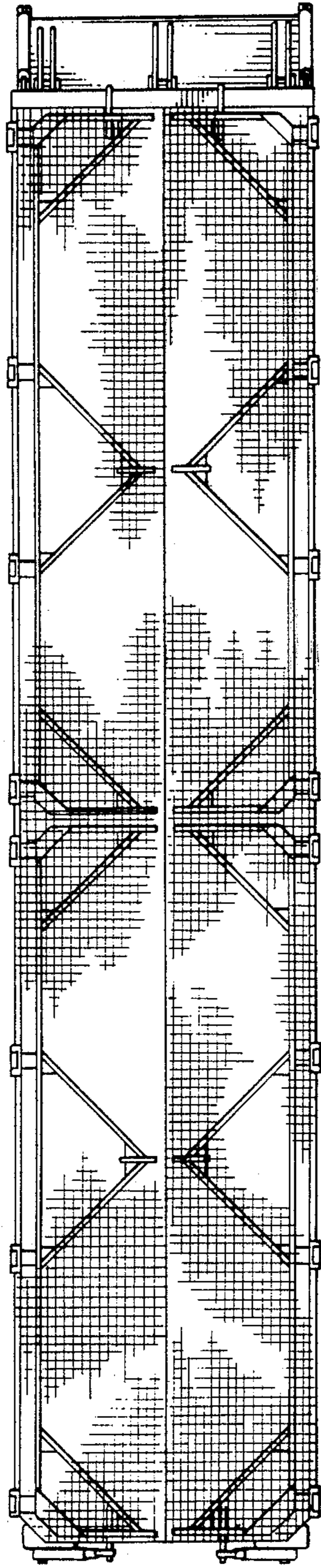

FIG. 5

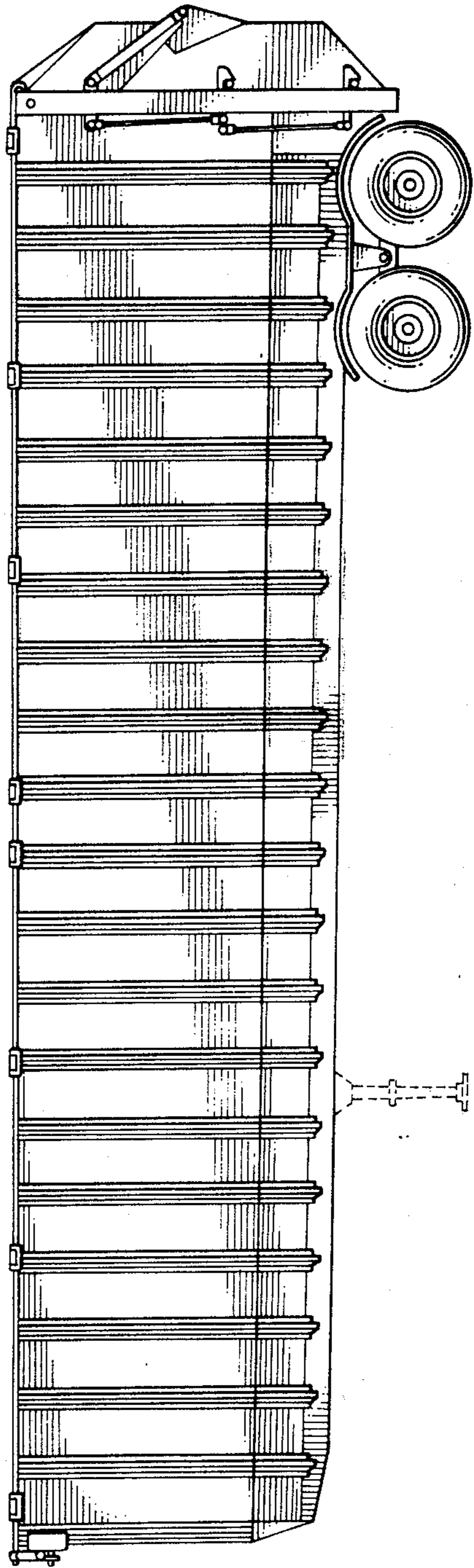

FIG. 2

FIG. 6

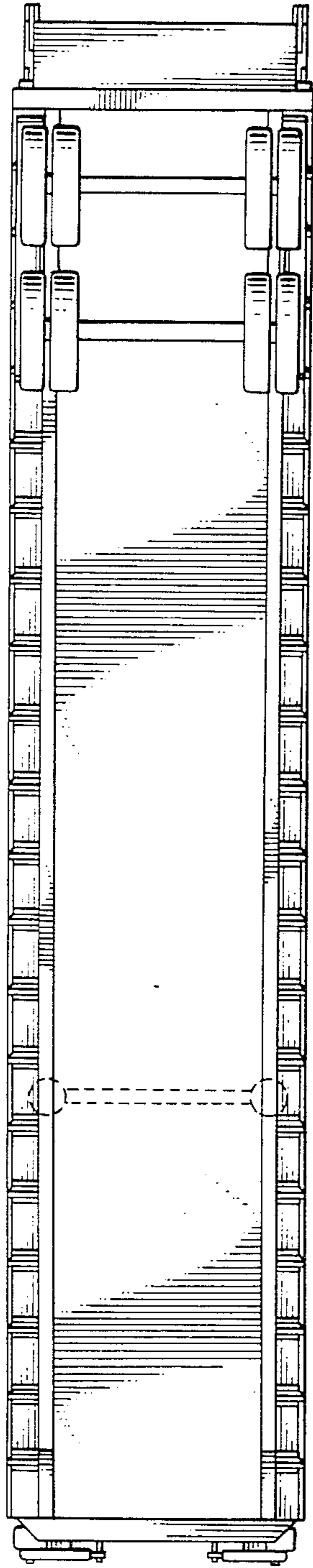

FIG. 7

