

[54] HYDRAULIC WRECKER AND BOOM HOUSING

[75] Inventor: Fleming V. Cannon, Jr., Flintstone, Ga.

[73] Assignee: Dover Corporation, Chattanooga, Tenn.

[**] Term: 14 Years

[21] Appl. No.: 709,927

[22] Filed: Mar. 8, 1985

Related U.S. Application Data

[63] Continuation-in-part of Ser. No. 681,900, Dec. 14, 1984.

[52] U.S. Cl. D12/14

[58] Field of Search D12/14, 13; D34/33, D34/34, 35, 36; 414/563; 280/402

[56] References Cited

U.S. PATENT DOCUMENTS

D. 252,921	9/1979	Nespor	D12/14
4,383,792	5/1983	Seabloom et al.	280/402
4,383,807	5/1983	Bulik	414/563
4,543,030	9/1985	Hawkins	414/563
4,563,018	1/1986	Stage et al.	414/563
4,600,353	7/1986	Phillips, Jr.	414/563

Primary Examiner—James M. Gandy
Assistant Examiner—Kay H. Chin
Attorney, Agent, or Firm—Alan Ruderman

[57] CLAIM

The ornamental design for a hydraulic wrecker and boom housing, substantially as shown.

DESCRIPTION

FIG. 1 is a rear perspective view of a hydraulic wrecker and boom housing embodying my new design; FIG. 2 is a top plan view thereof; FIG. 3 is a rear elevational view thereof; FIG. 4 is a one side elevational view thereof; FIG. 5 is a front elevational view thereof; and FIG. 6 is the other side elevational view thereof.

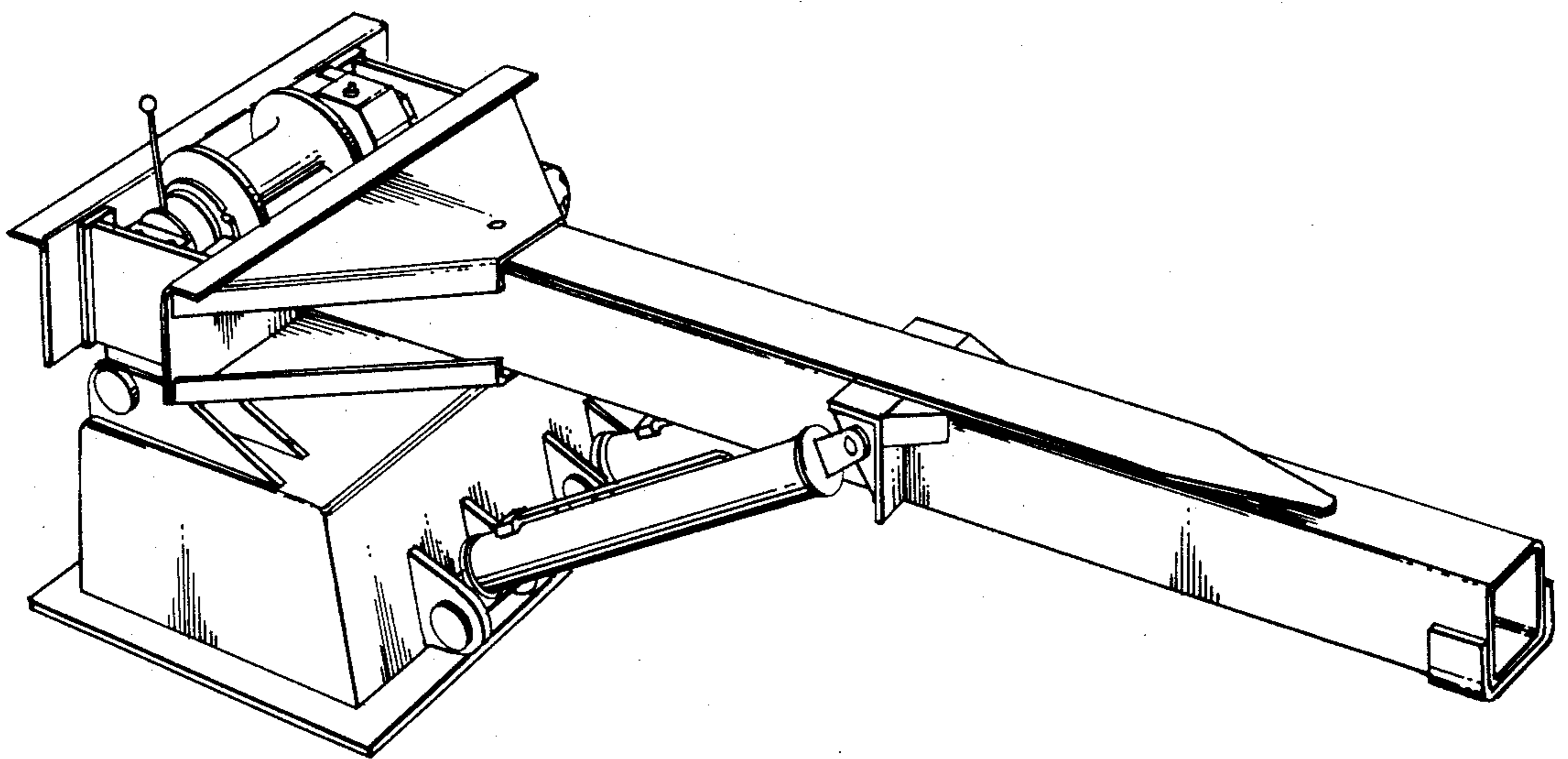

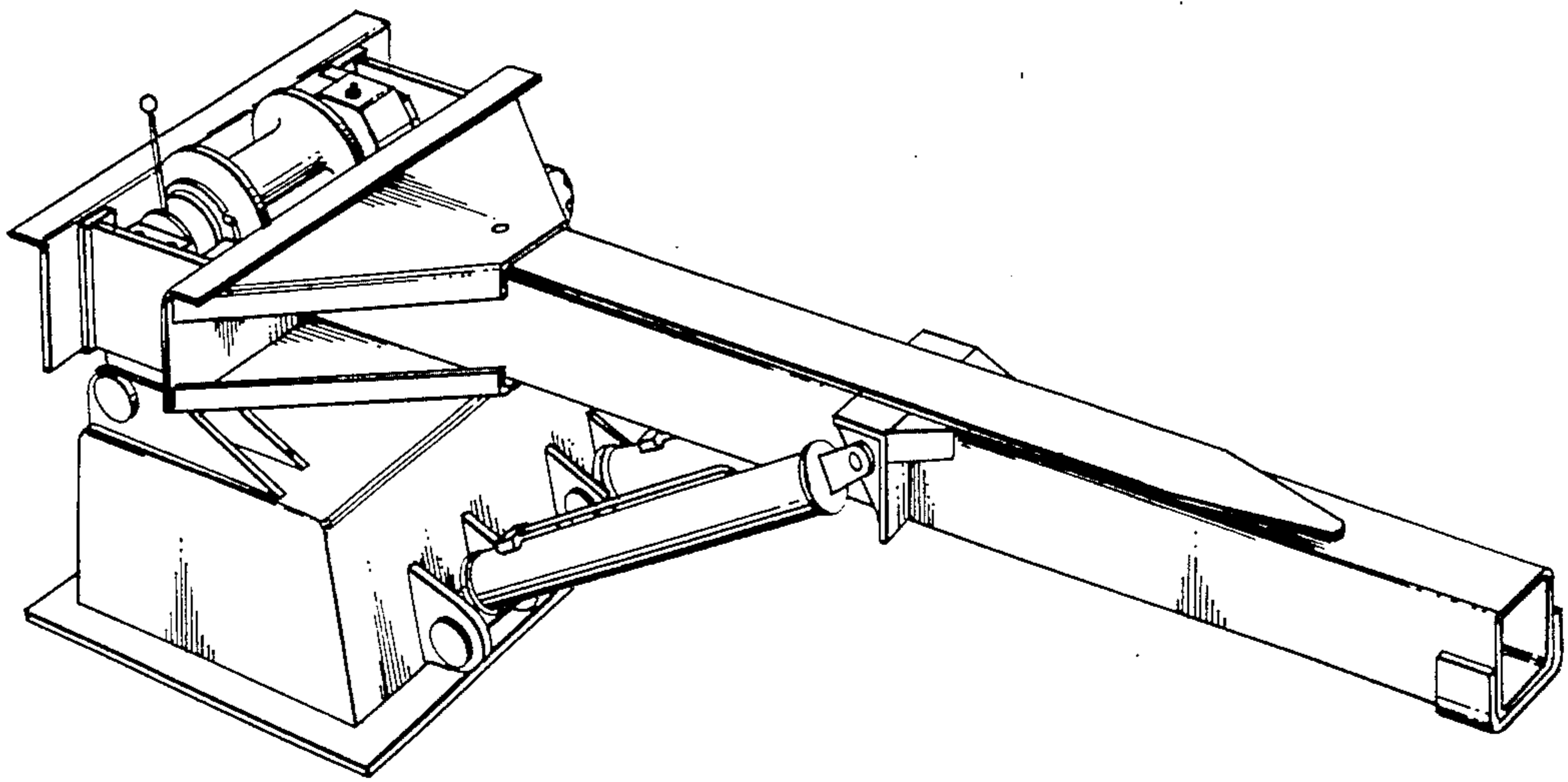

FIG. 1

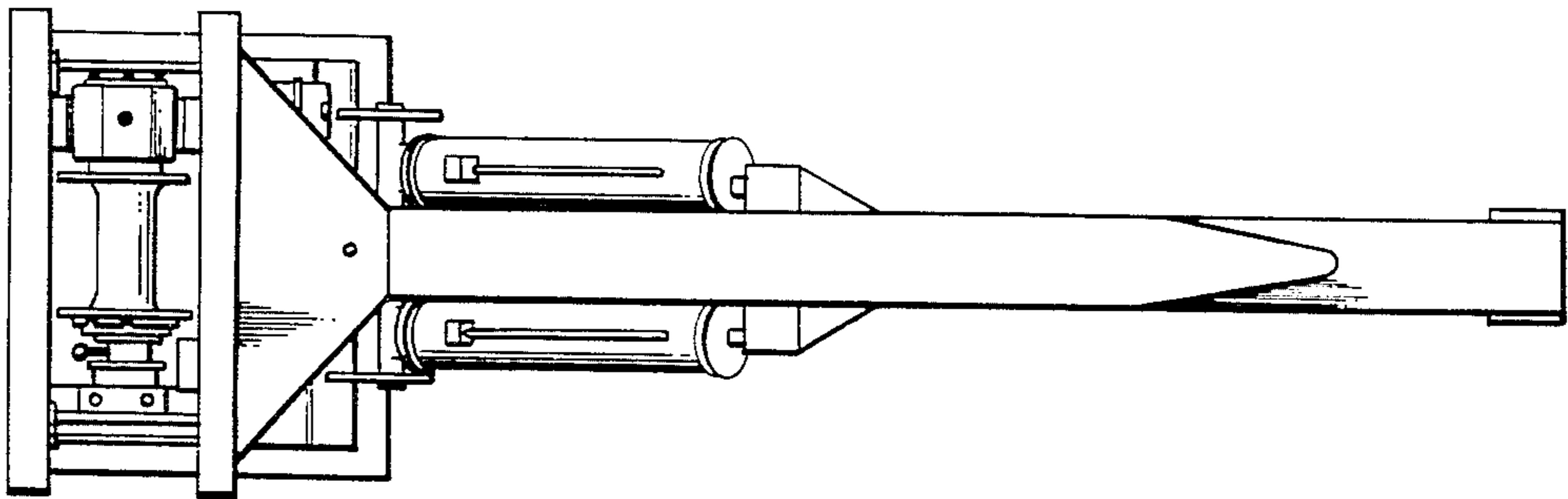

FIG. 2

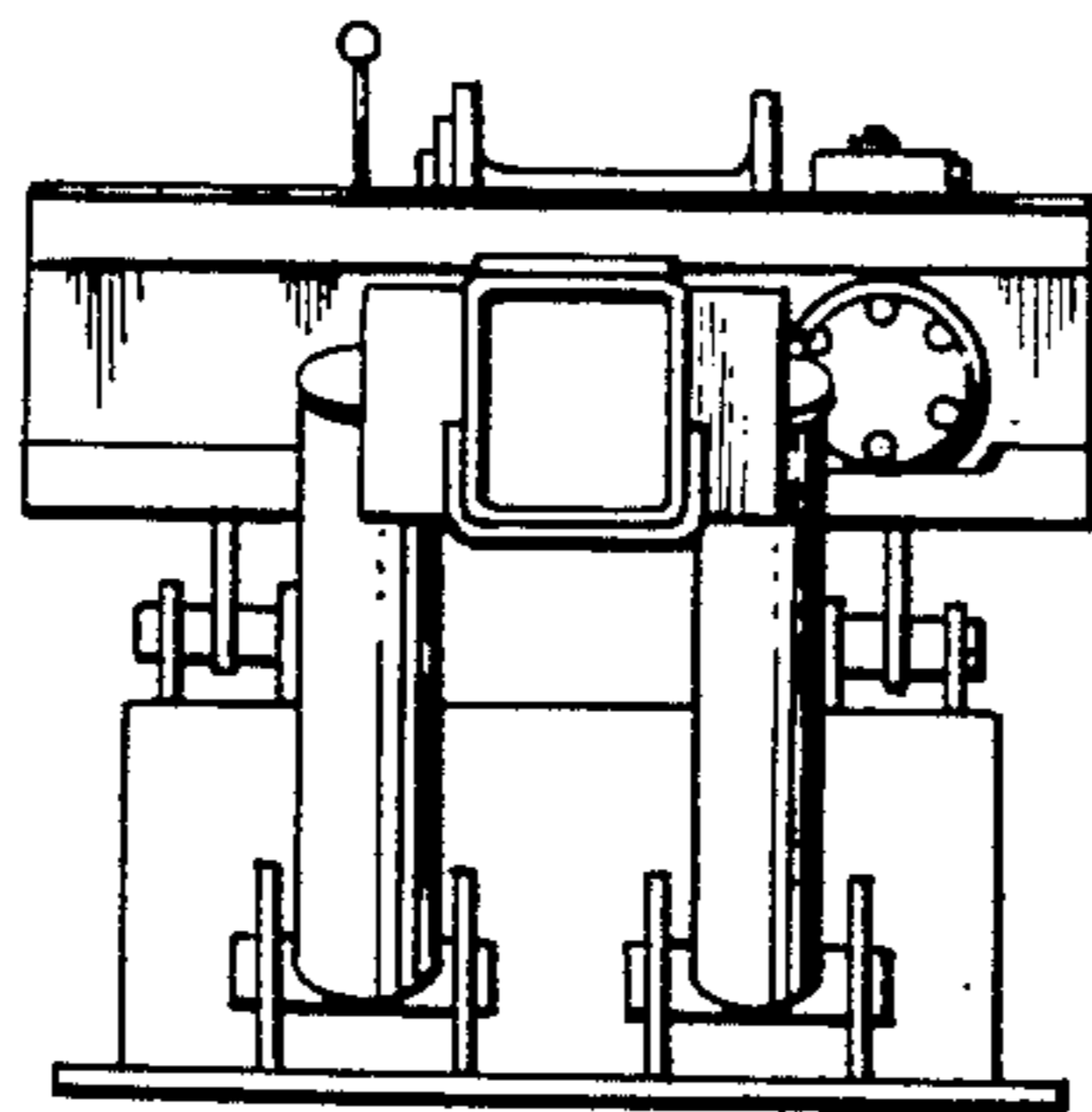

FIG. 3

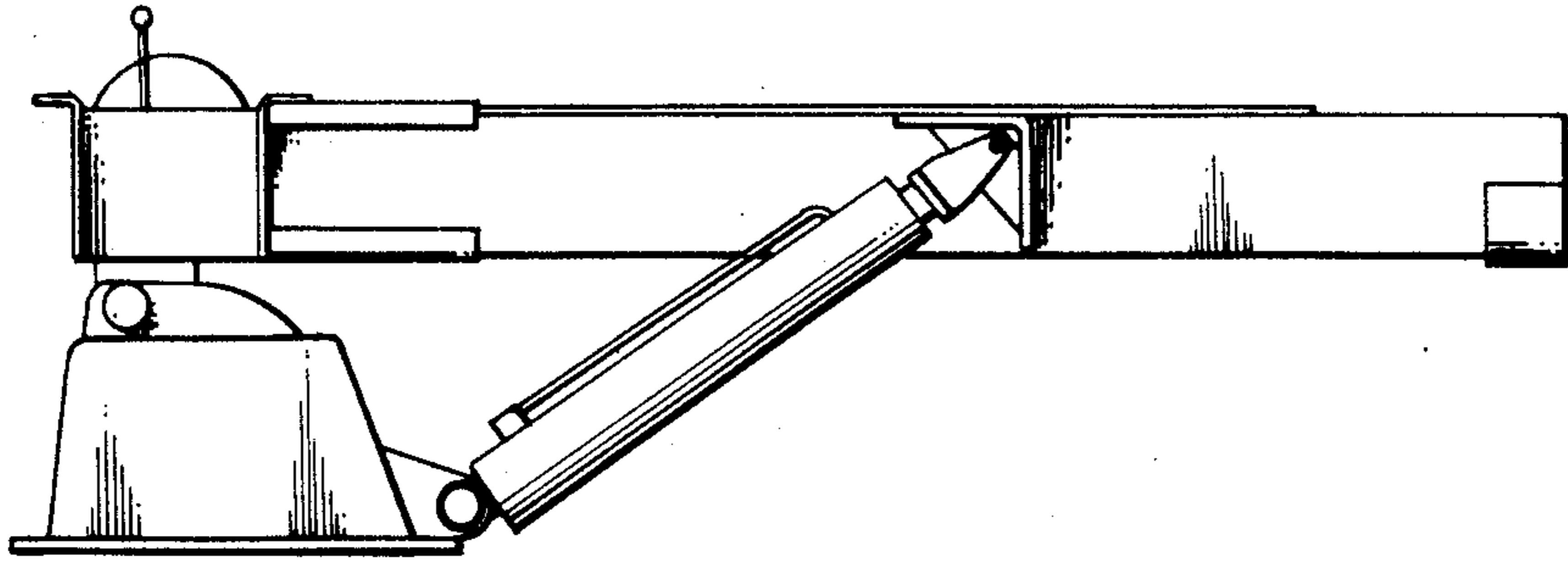

FIG. 4

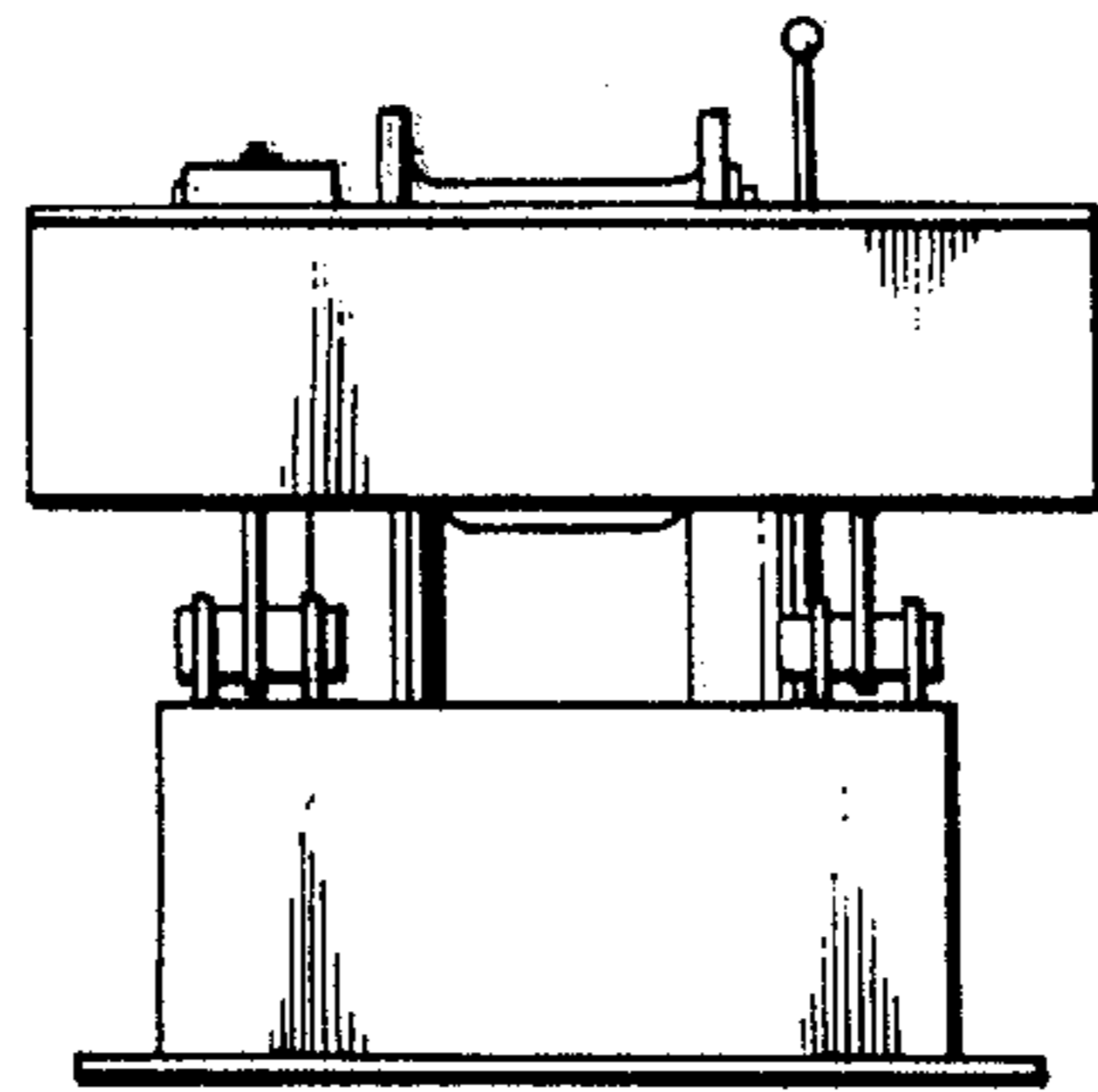

FIG. 5

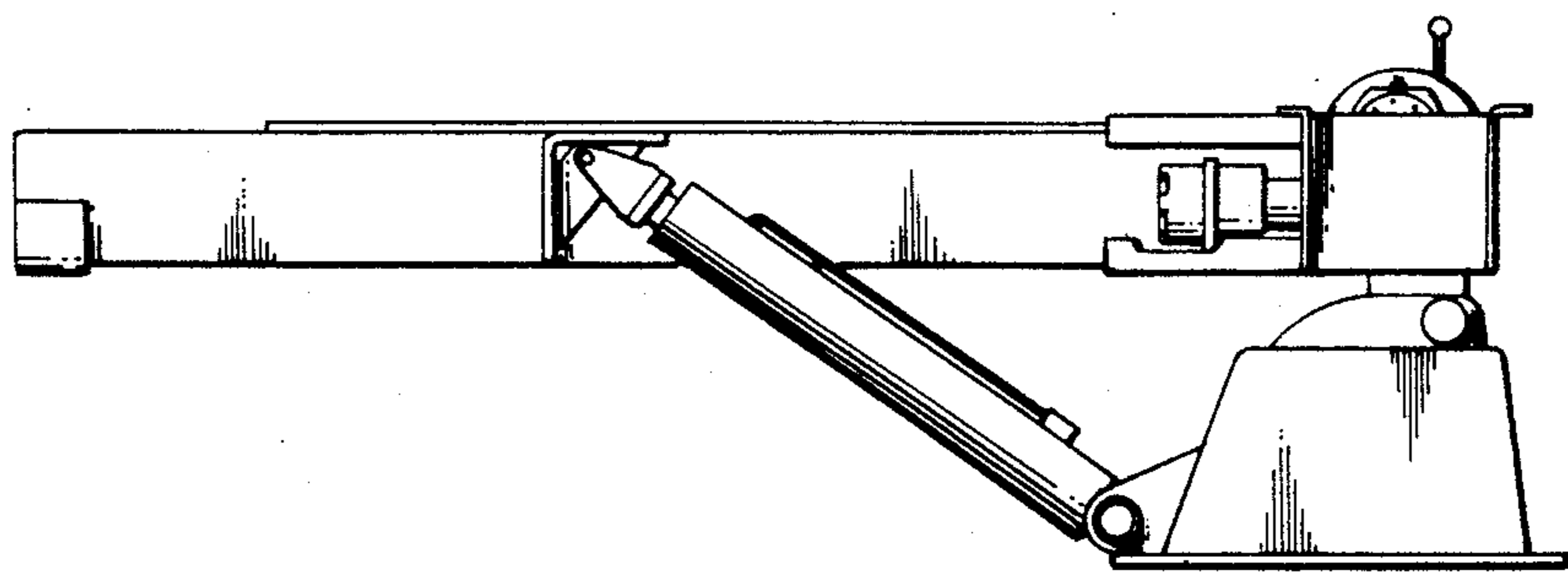

FIG. 6