

[54] FIVE WHEELED CHILD'S CYCLE

[76] Inventors: Elliot A. Rudell, 2215 237th St., Torrance, Calif. 90501; Joseph S. Cernansky, 14610 S. Halldale Ave., Gardena, Calif. 90247; Richard P. Kamrath, 2916 Gibson Pl., Redondo Beach, Calif. 90278

[**] Term: 14 Years

[21] Appl. No.: 658,877

[22] Filed: Oct. 9, 1984

[52] U.S. Cl. D12/108

[58] Field of Search D12/108, 112; D21/79, D21/78; 280/1.11 R, 282; 296/177

[56] References Cited

U.S. PATENT DOCUMENTS

- D. 232,307 8/1974 Manofsky D12/112
- D. 263,944 4/1982 Arad et al. D12/112
- D. 271,315 11/1983 Nottingham et al. D21/79

OTHER PUBLICATIONS

1982 Sears Christmas catalog, p. 562, Dukes of Hazzard Spin-Rider Cycle, No. 5, top right side of page.

Primary Examiner—James M. Gandy

Attorney, Agent, or Firm—Plante Strauss Vanderburgh

[57] CLAIM

The ornamental design for a five wheeled child's cycle, as shown and described.

DESCRIPTION

FIG. 1 is a top plan view of the tanker back truck embodiment of the five wheeled child's cycle showing our new design;

FIG. 2 is a side elevational view thereof, the opposite side being a mirror image of that shown.

FIG. 3 is a front elevational view thereof;

FIG. 4 is a back elevational view thereof;

FIG. 5 is a top plan view of the dump back truck embodiment of the five wheeled child's cycle showing our new design;

FIG. 6 is a side elevational view of FIG. 5, the opposite side being a mirror image of that shown;

FIG. 7 is a front elevational view of FIG. 5;

FIG. 8 is a back elevational view of FIG. 5;

FIG. 9 is a top plan view of the closed back truck embodiment of the five wheeled child's cycle showing our new design;

FIG. 10 is a side elevational view of FIG. 9, the opposite side being a mirror image of that shown;

FIG. 11 is a front elevational view of FIG. 9; and

FIG. 12 is a back elevational view of FIG. 9.

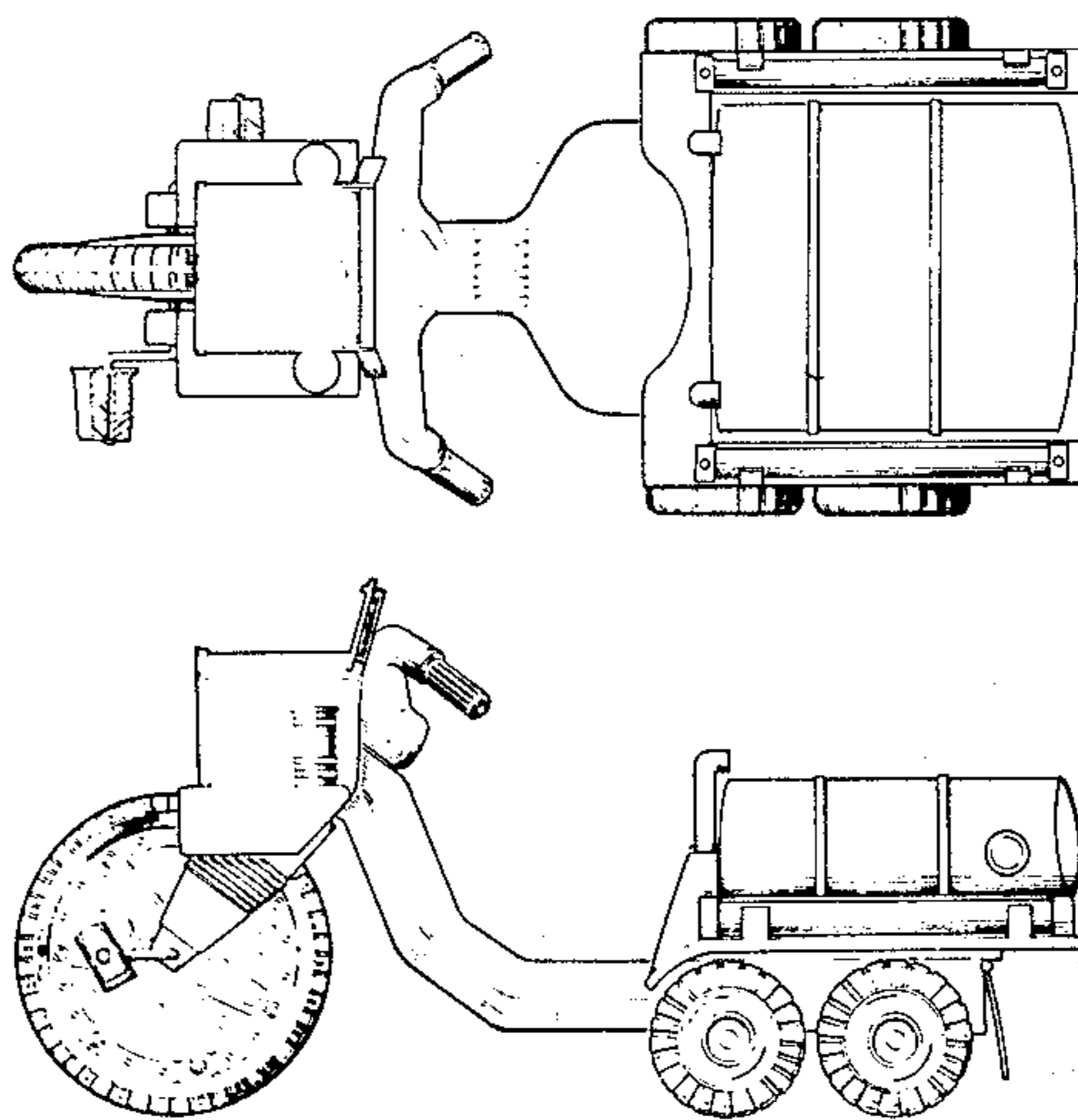

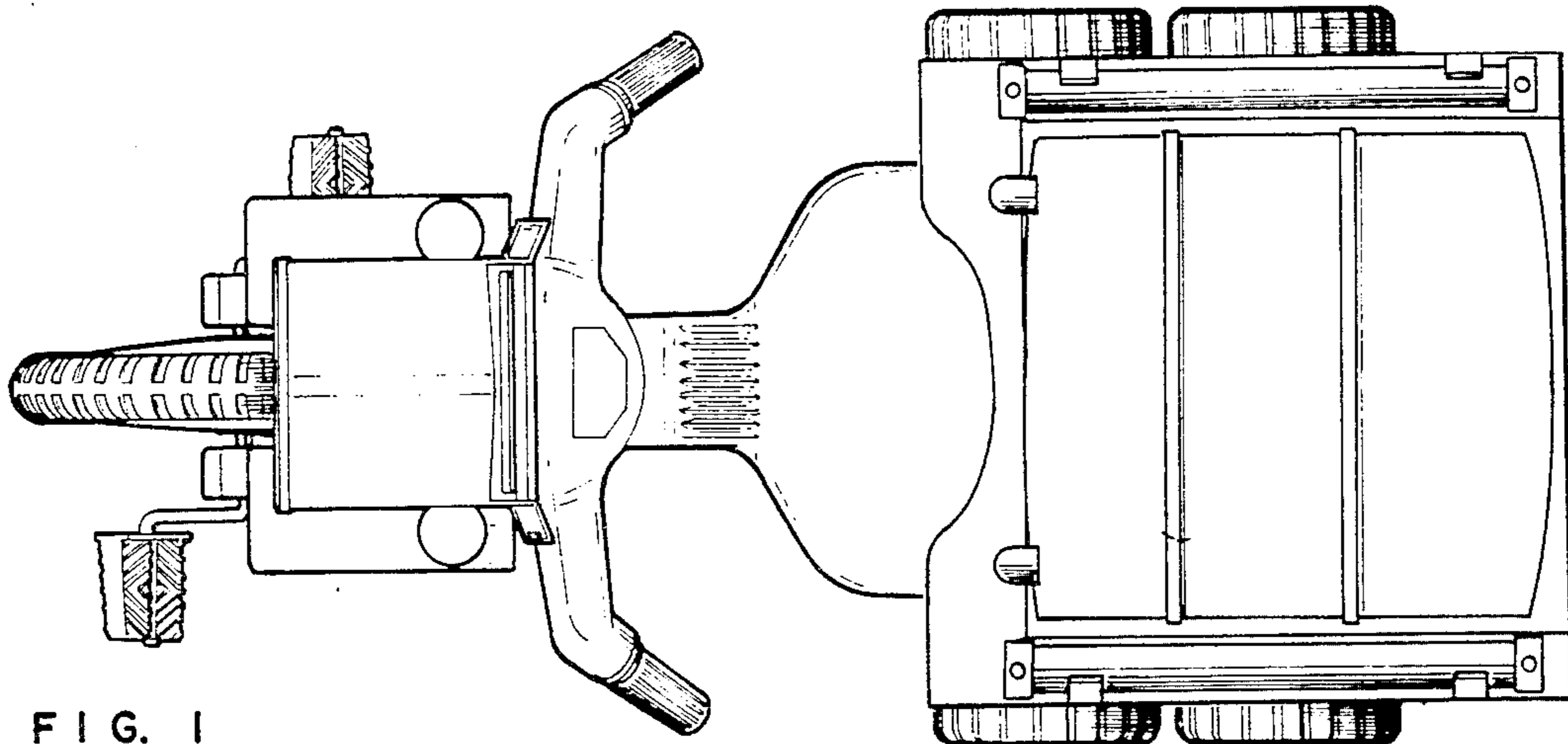

FIG. 1

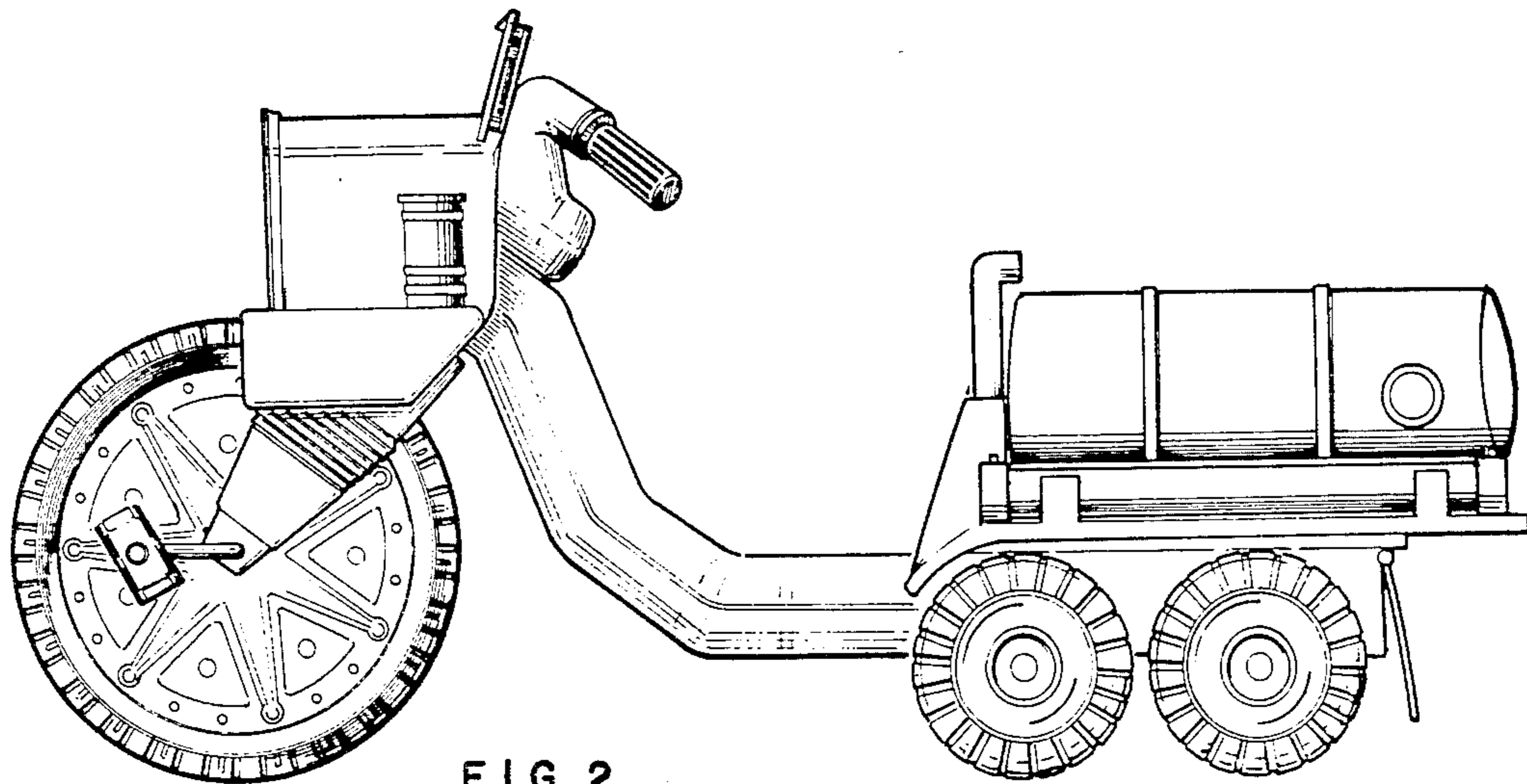

FIG. 2

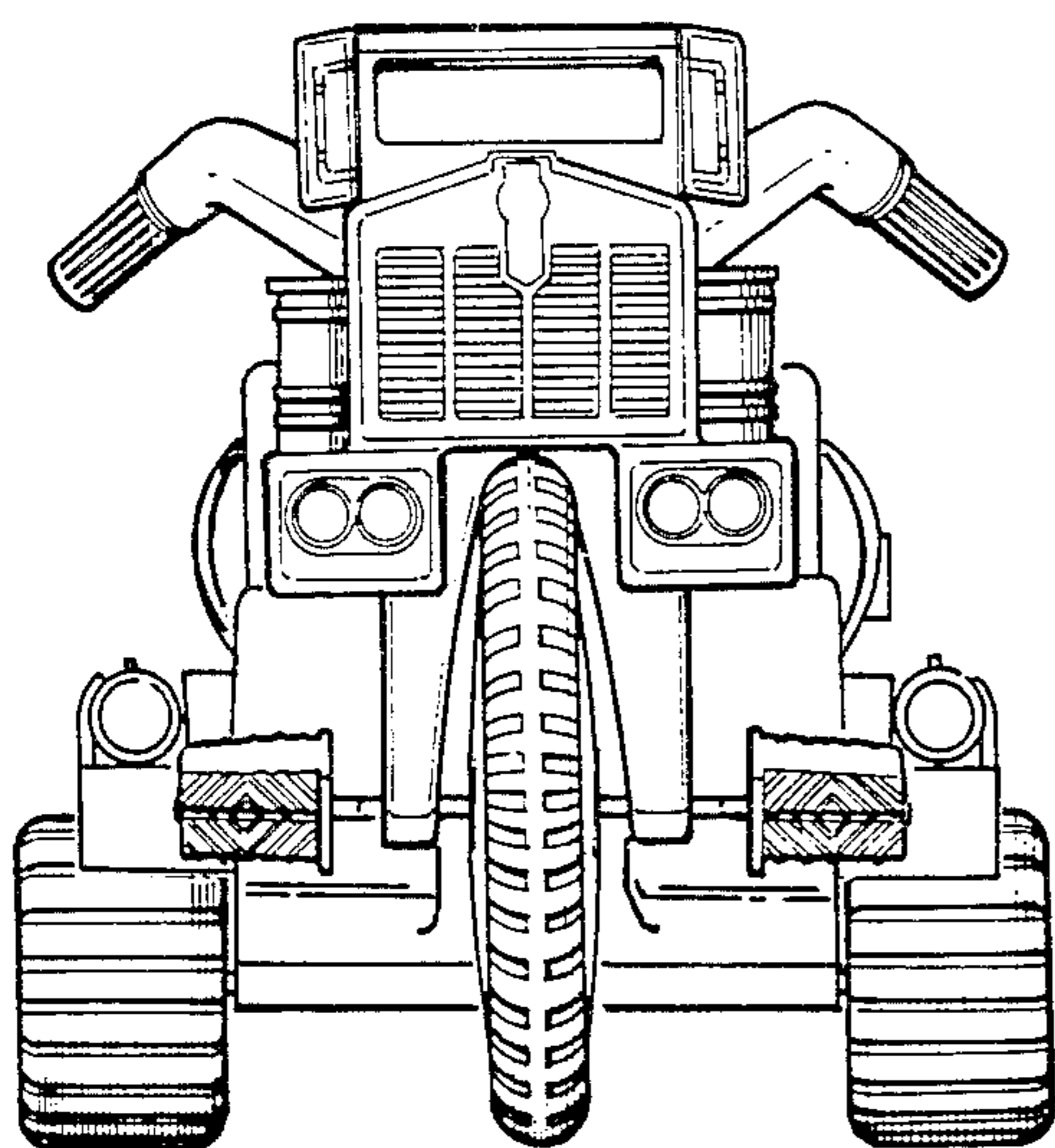

FIG. 3

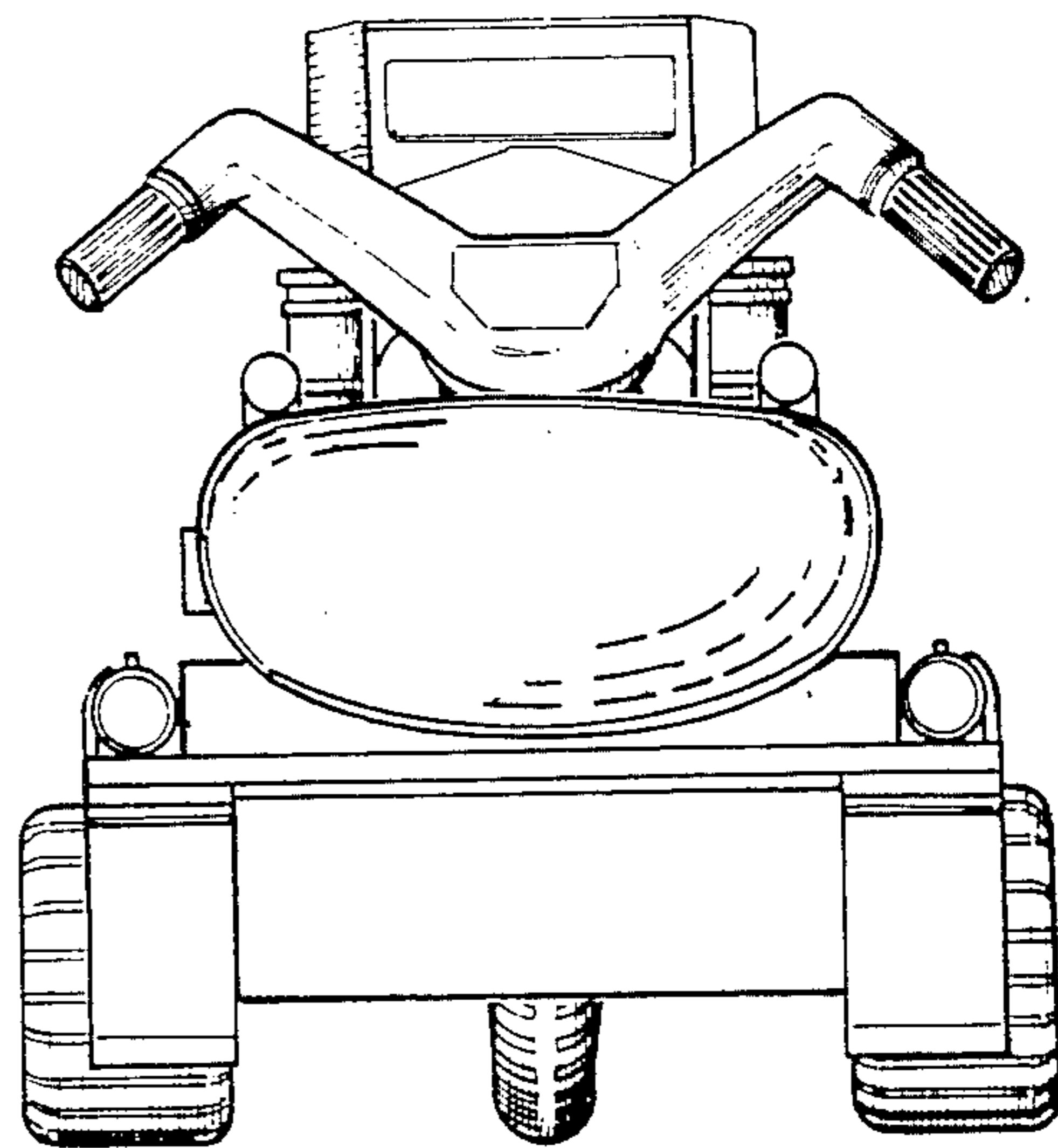

FIG. 4

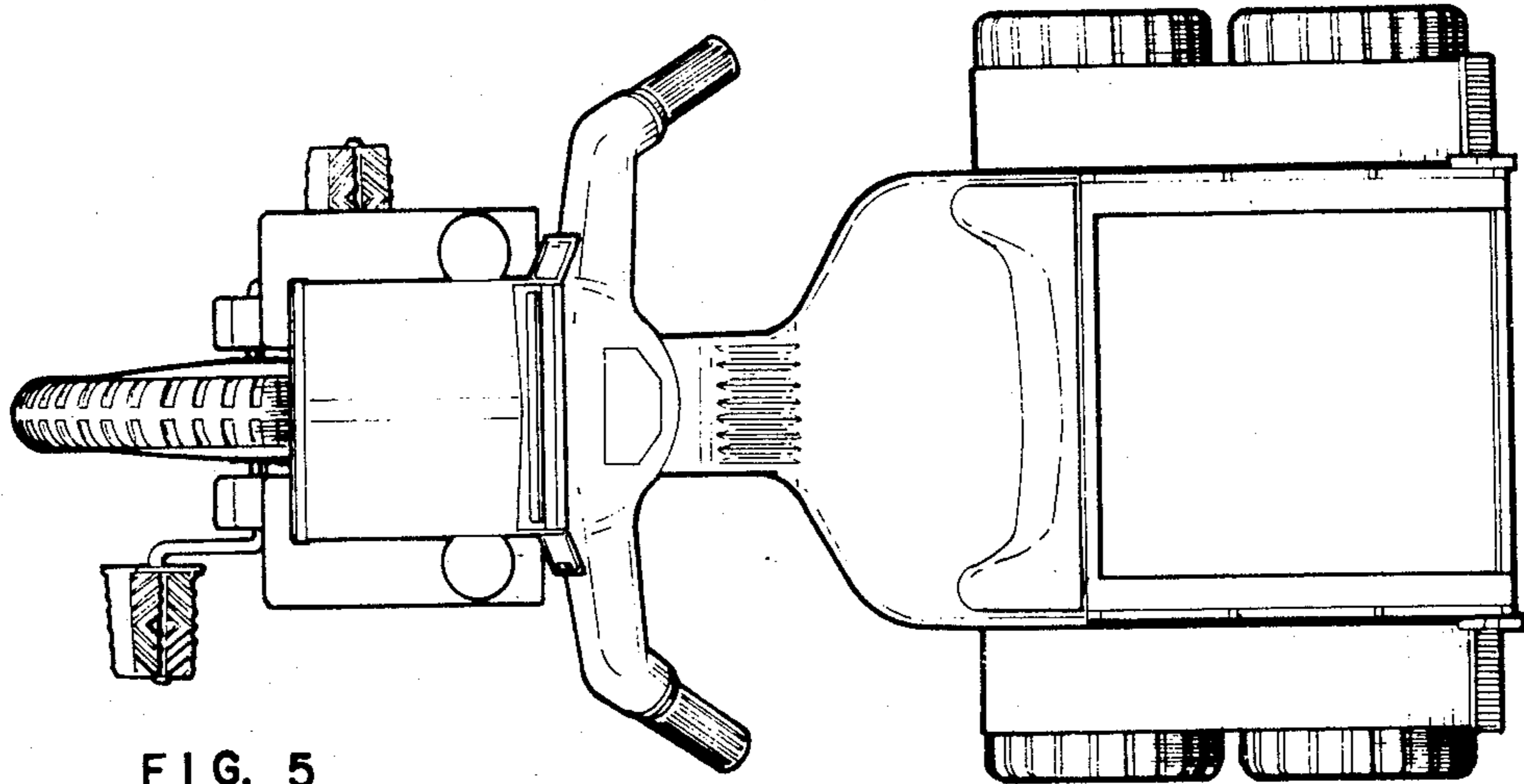

FIG. 5

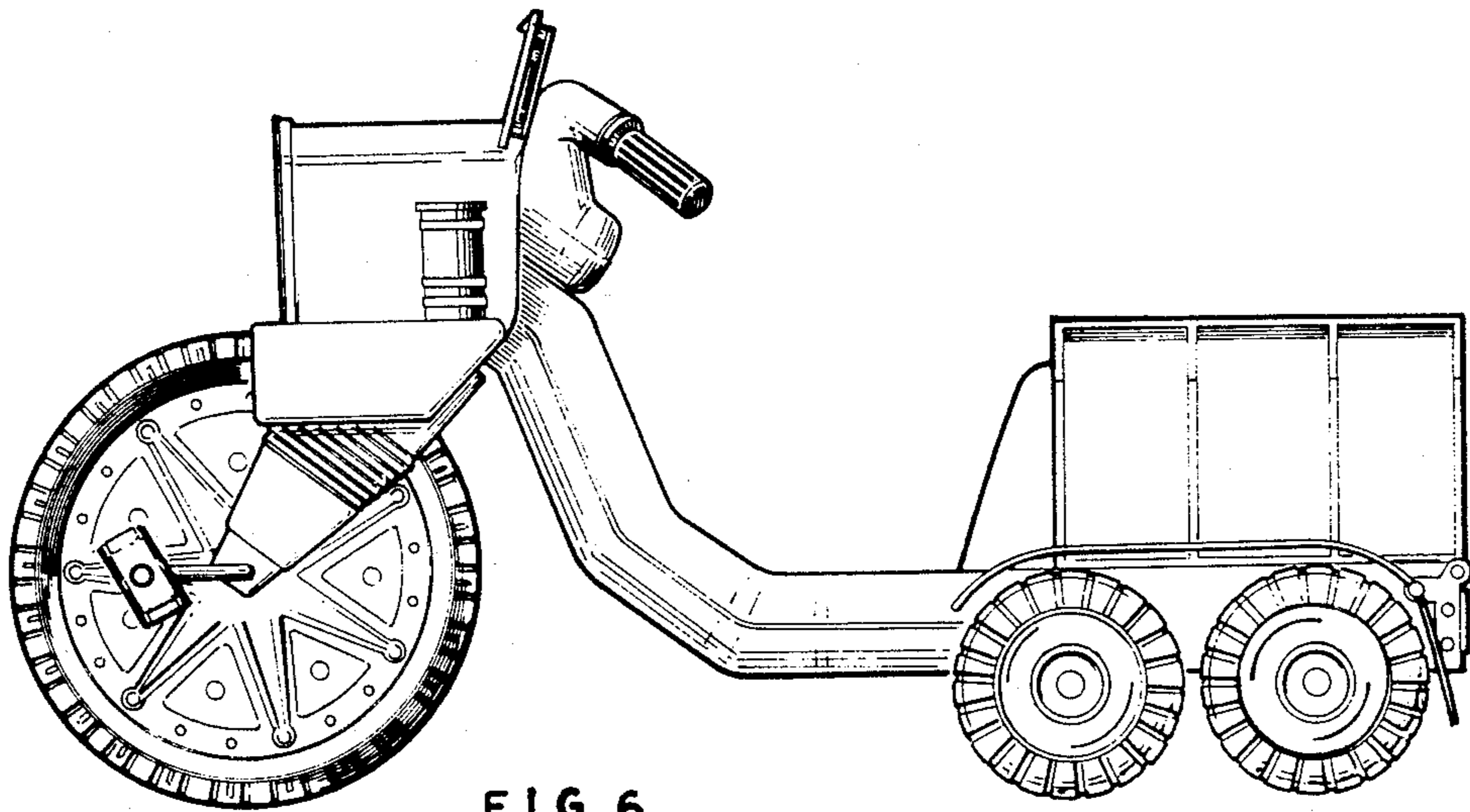

FIG. 6

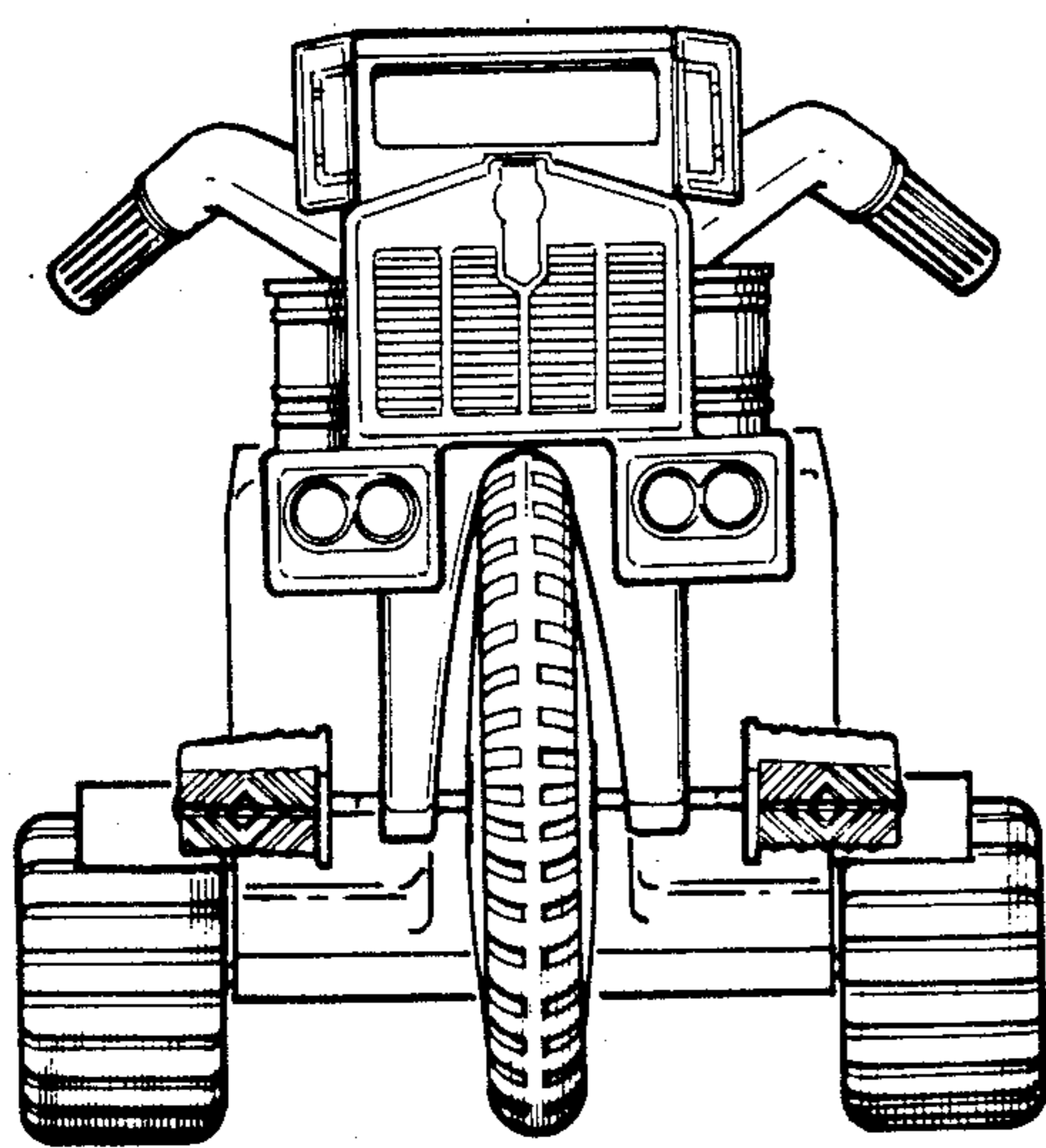

FIG. 7

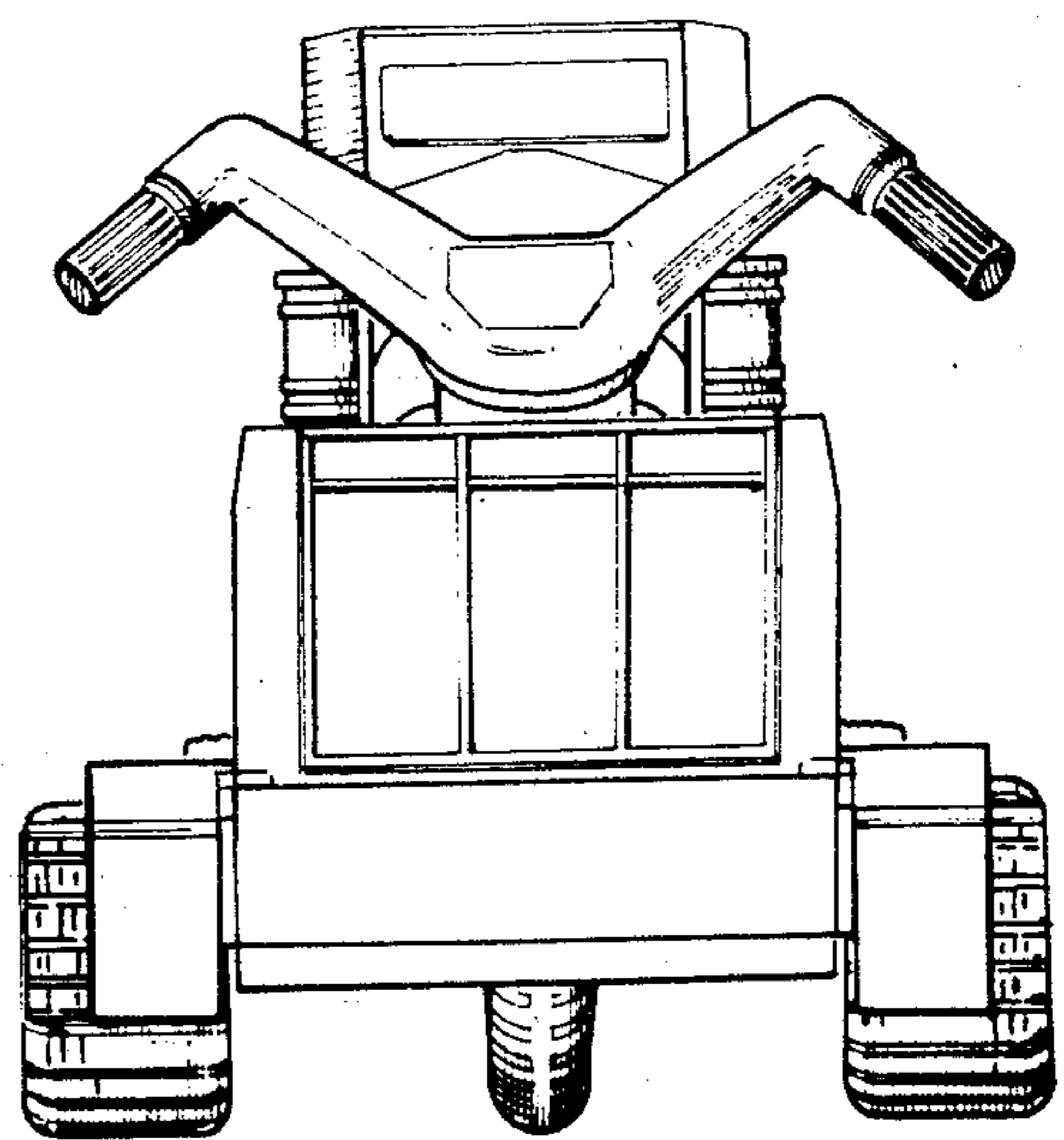

FIG. 8

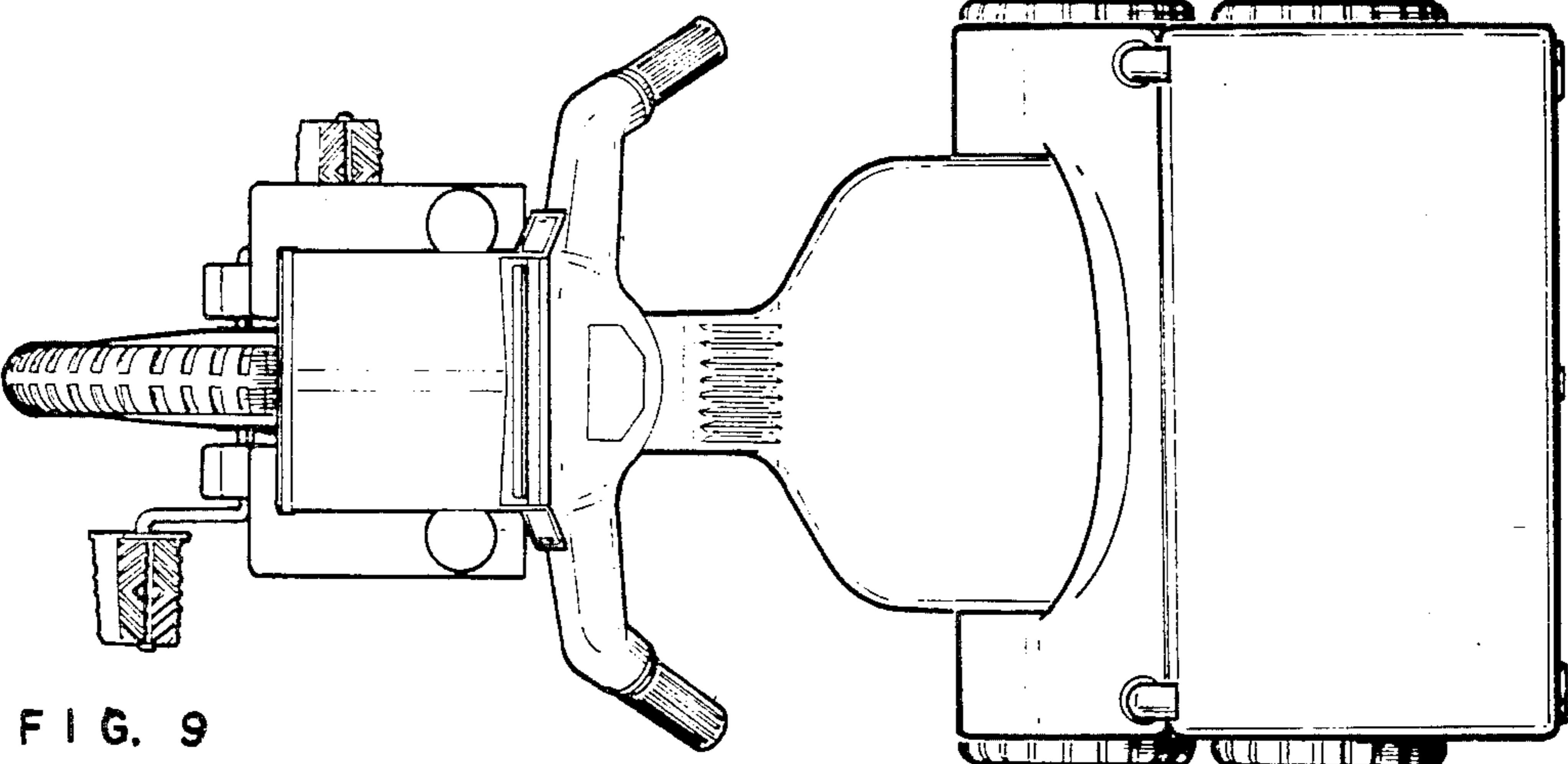

FIG. 9

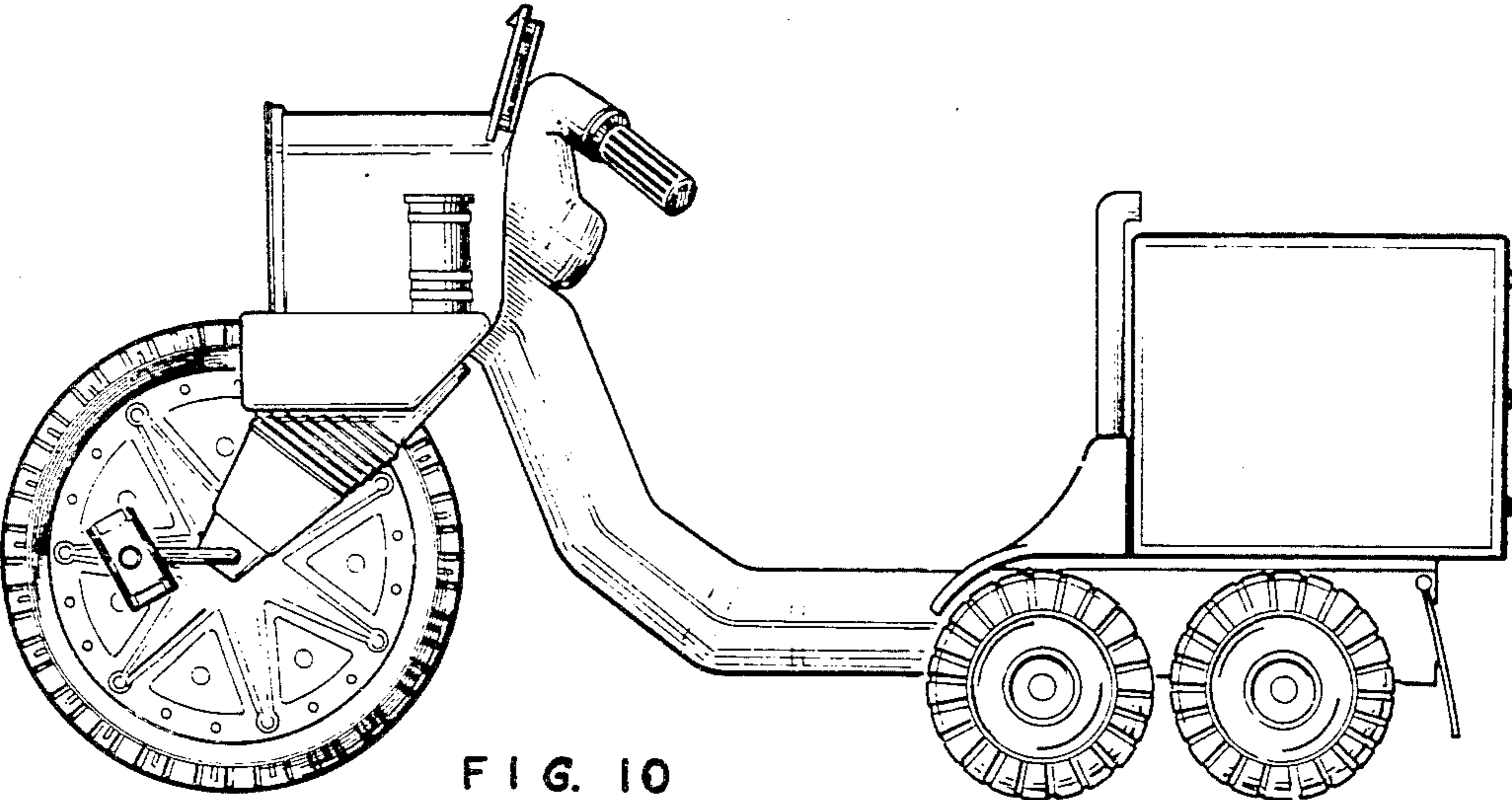

FIG. 10

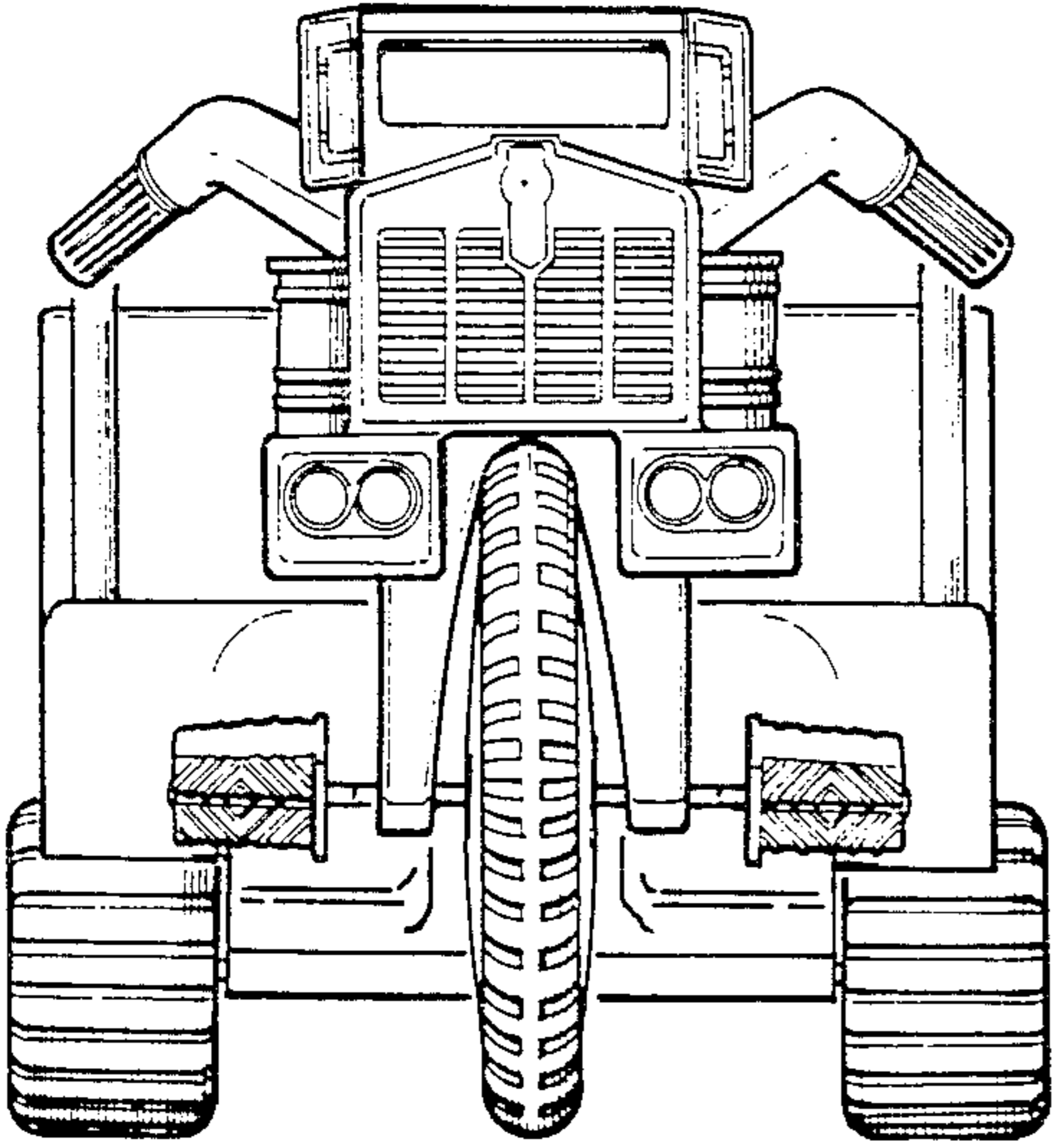

FIG. 11

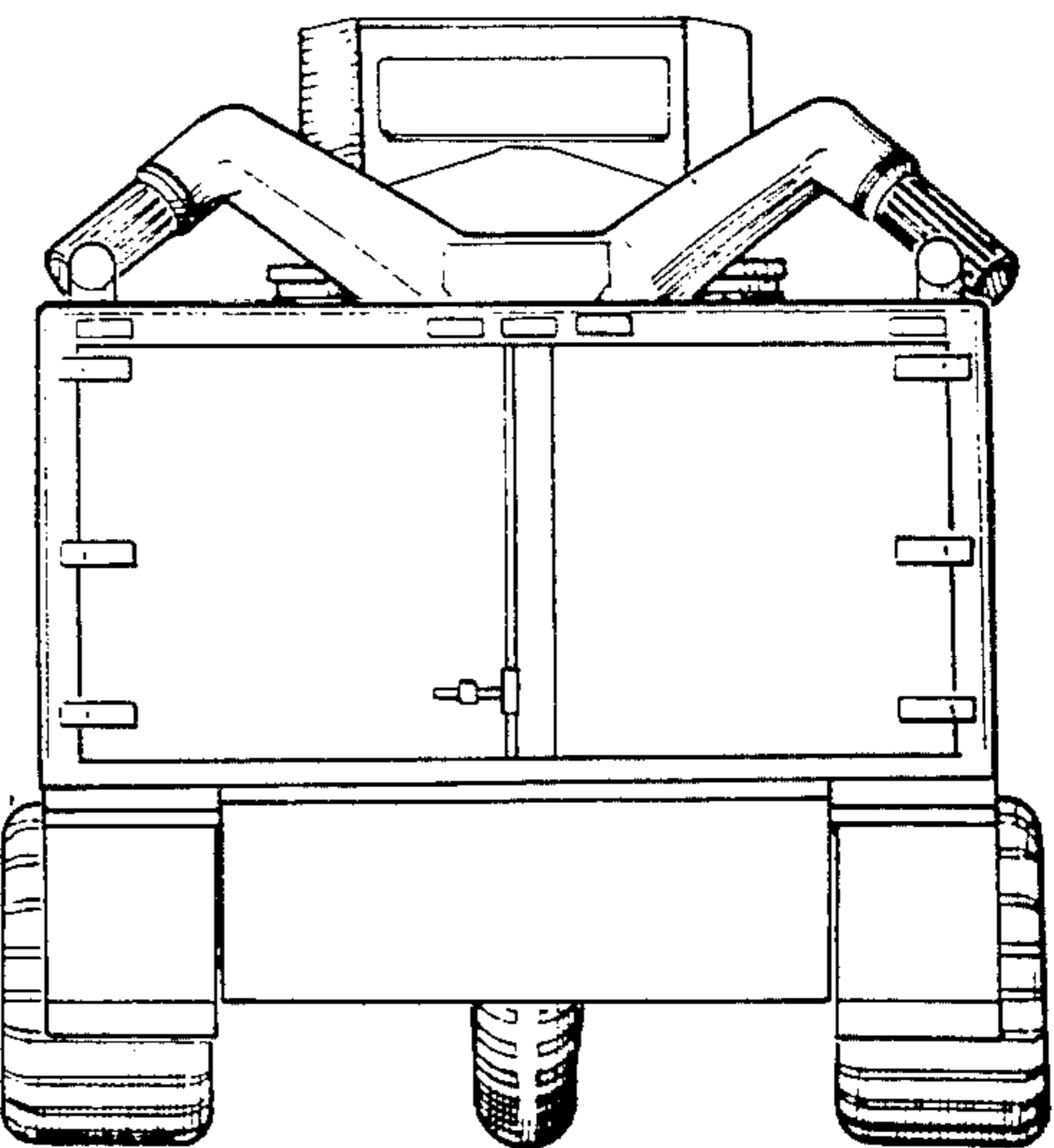

FIG. 12