

[54] WHEEL

[75] Inventor: Manfred Lorinser, Waiblingen, Fed. Rep. of Germany

[73] Assignee: Atg-Autoteile-Grosshandel GmbH, Waiblingen, Fed. Rep. of Germany

[\*\*] Term: 14 Years

[21] Appl. No.: 620,551

[22] Filed: Jun. 14, 1984

[30] Foreign Application Priority Data

Feb. 20, 1984 [XH] Hague ..... DM/003 442

[52] U.S. Cl. .... D12/211

[58] Field of Search ..... D12/209-211; 301/63 R, 64 R, 64 SD, 65

[56] References Cited

U.S. PATENT DOCUMENTS

- D. 244,845 6/1977 Woodward ..... D12/211
- D. 268,261 3/1983 Boyer ..... D12/211
- 4,533,184 8/1985 Muller et al. .... 301/65

OTHER PUBLICATIONS

Road & Track, 1/83, p. 40C, Dodge Challenger Wheel, center left side of page.

Motor Trend, 7/83, p. 38, BMW 320i Wheel, bottom center of page.

Design, 7/80, p. 37, Wheel, center right side of page.

Primary Examiner—James M. Gandy

Attorney, Agent, or Firm—Michael J. Striker

[57] CLAIM

The ornamental design for a wheel, as shown and described.

DESCRIPTION

FIG. 1 is a front elevation view of a first embodiment of a wheel embodying my new design.

FIG. 2 is a rear elevation view thereof.

FIG. 3 is a sectional view thereof taken along line 3—3 in FIG. 1.

FIG. 4 is a front elevation view of a second embodiment of a wheel embodying my new design.

FIG. 5 is a rear elevation view of the second embodiment.

FIG. 6 is a sectional view of the second embodiment taken along line 6—6 in FIG. 4.

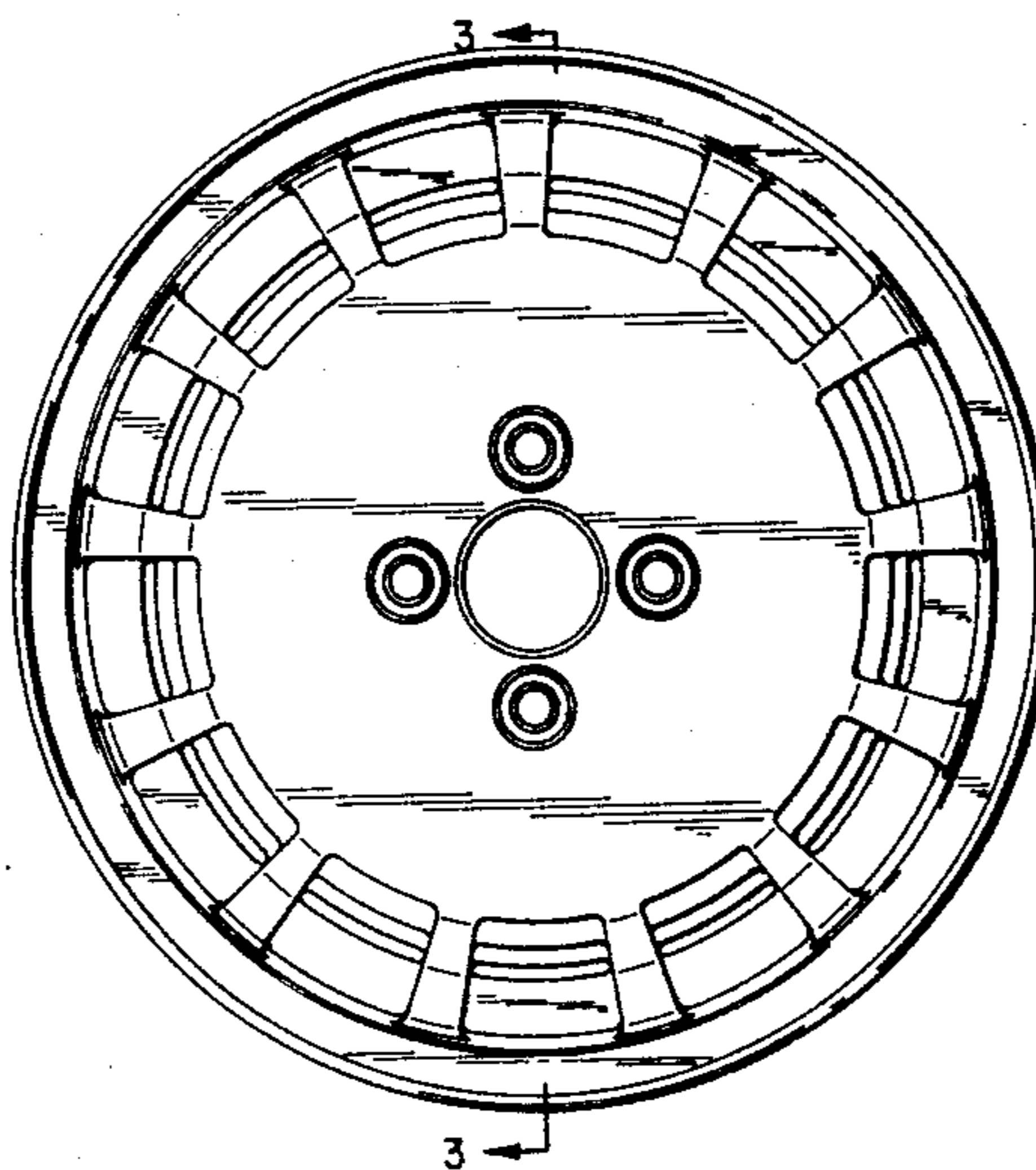

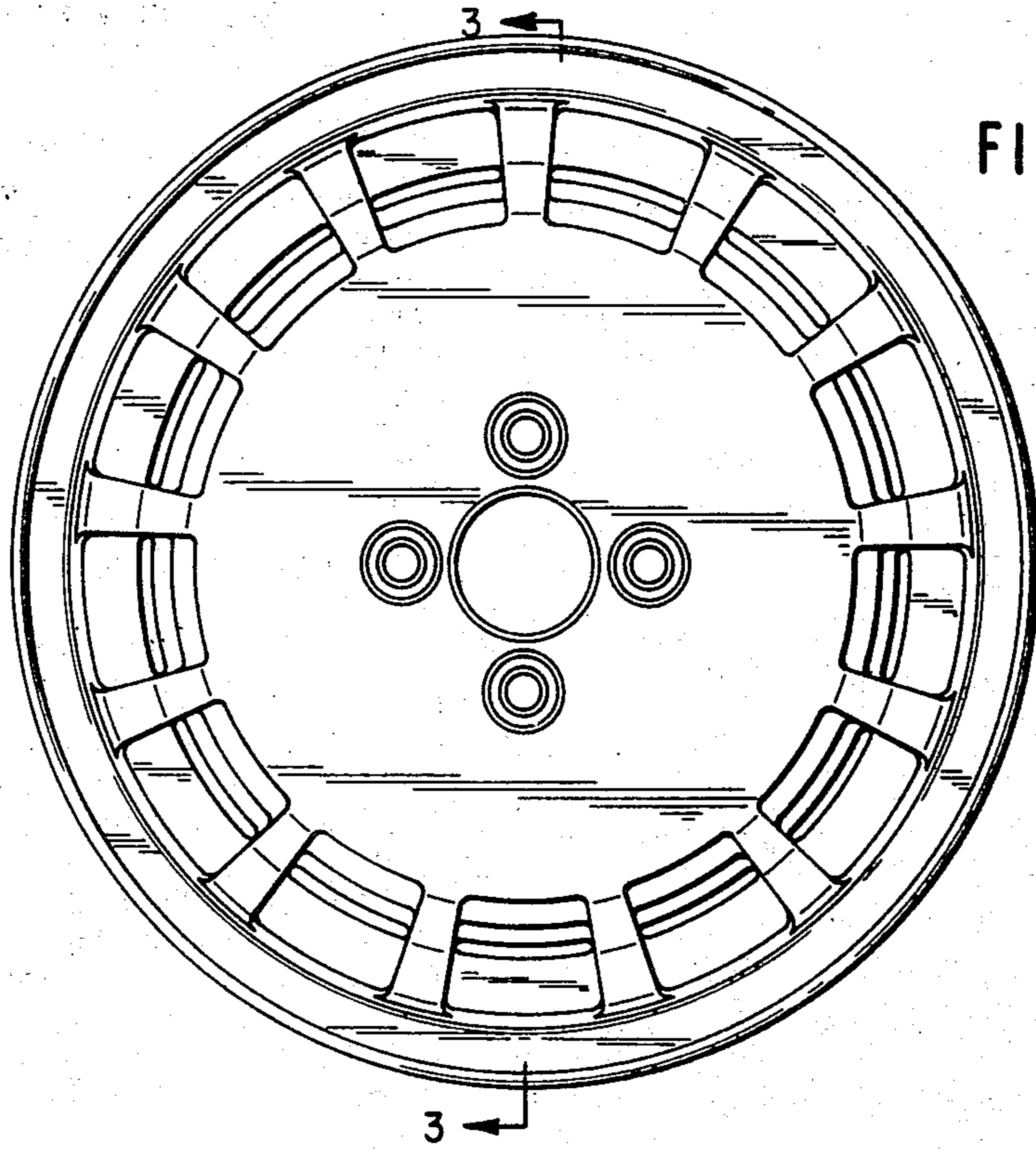

FIG. 1

FIG. 2

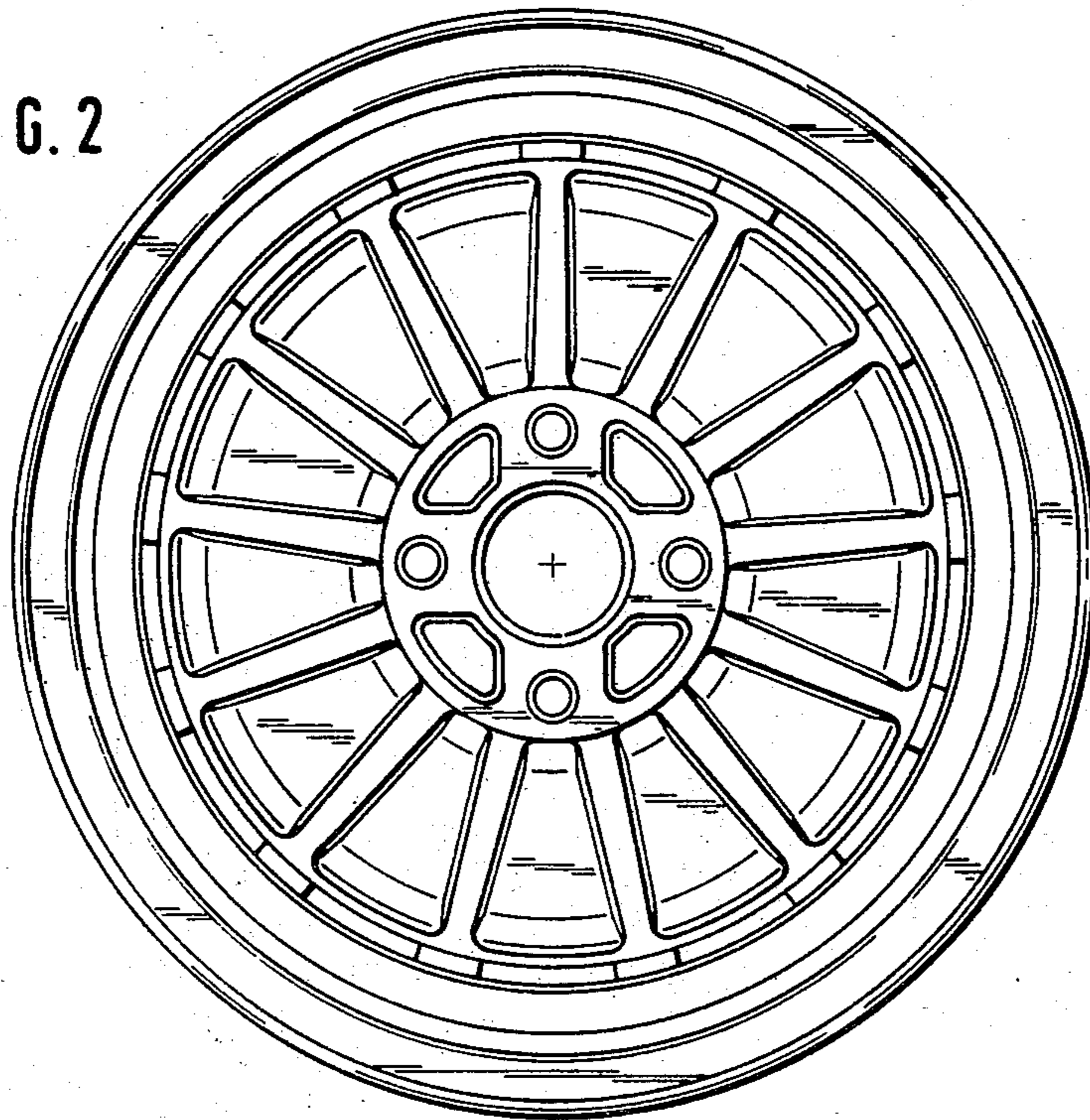

FIG. 3

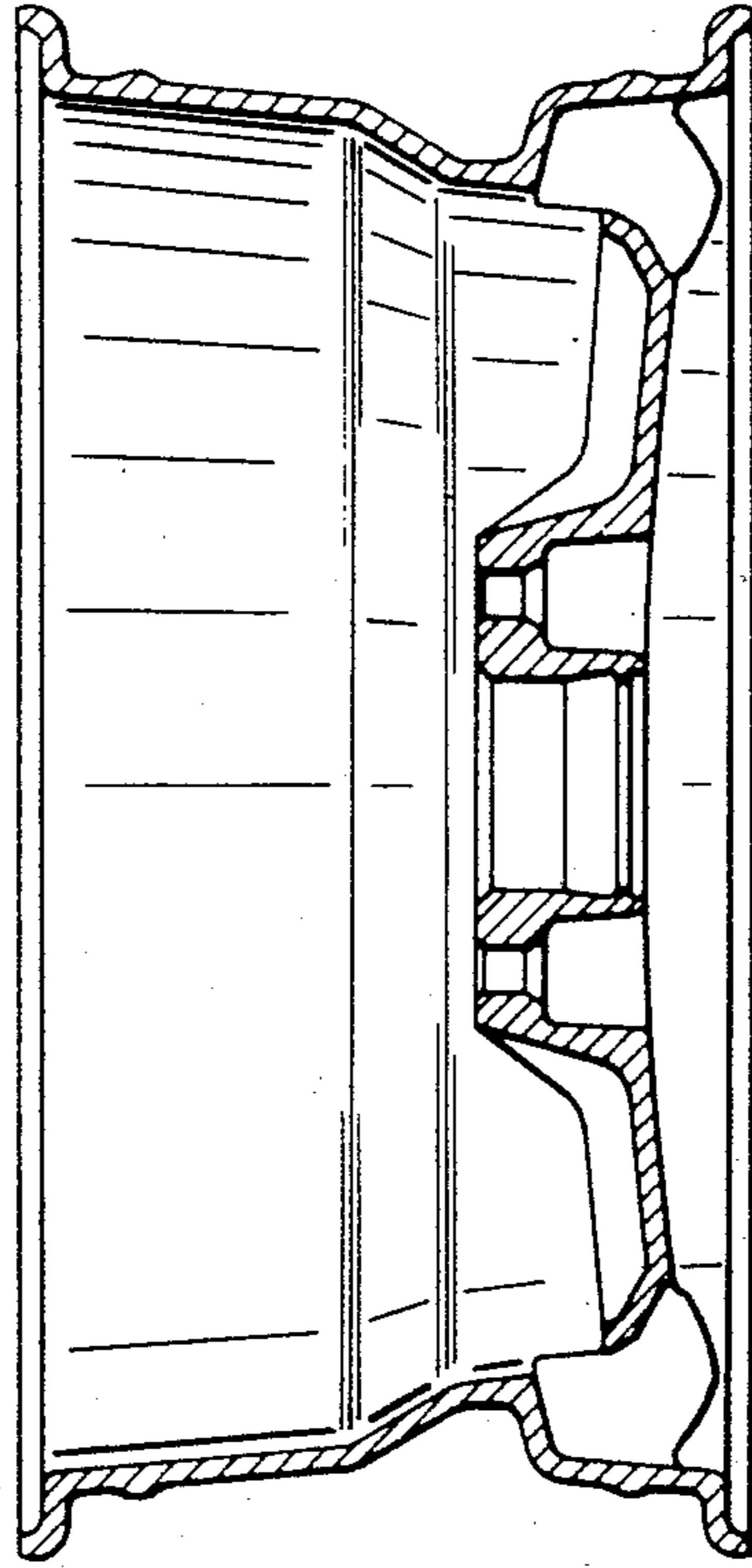

FIG. 4

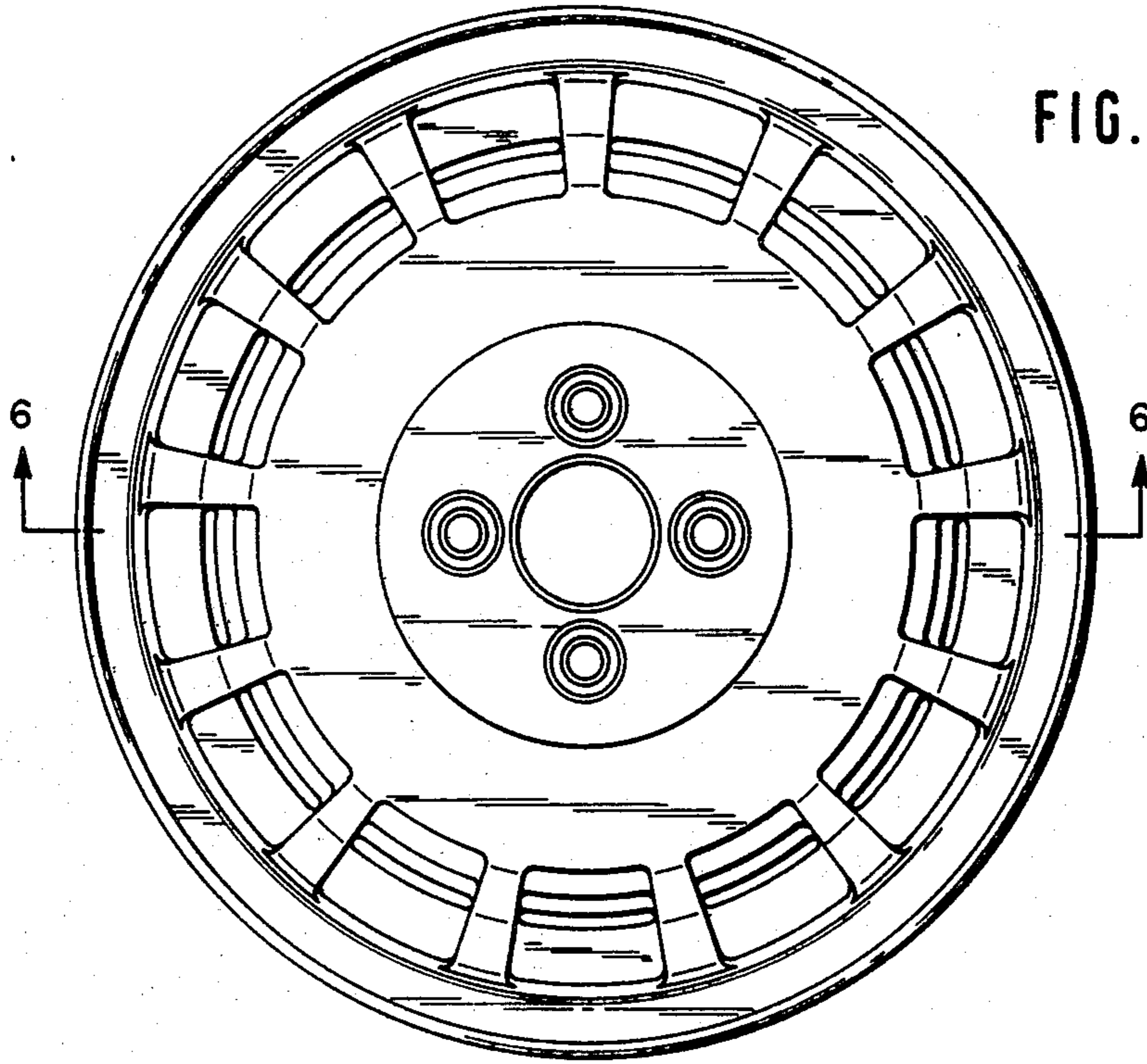

FIG. 5

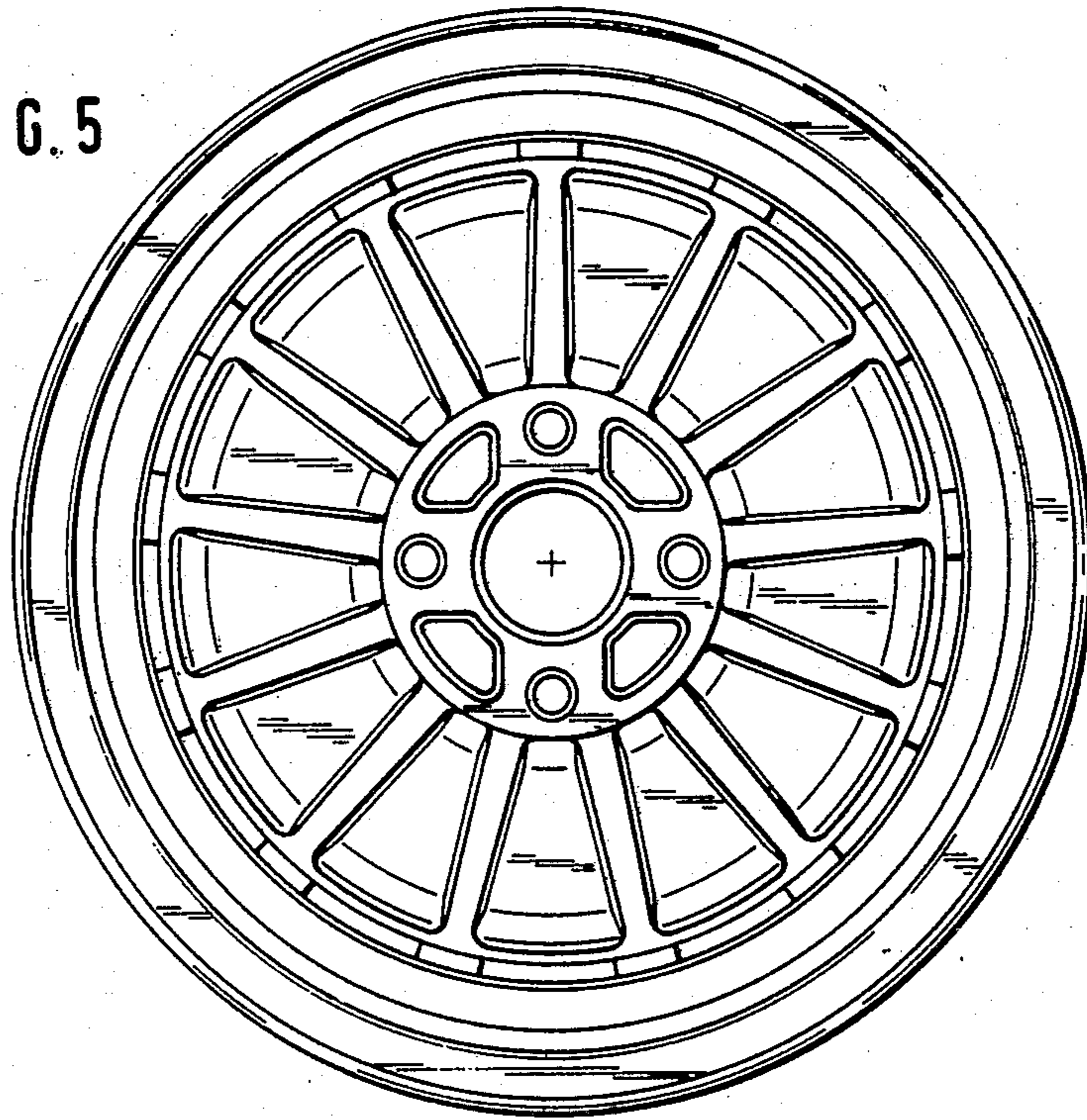

FIG. 6

