

[54] MEMO PAD HOLDER

D. 200,370 2/1965 Sherman ..... D19/20  
D. 258,469 3/1981 Lee ..... D3/78  
D. 273,798 5/1984 Pearson ..... D19/78

[75] Inventors: Michael J. Hennigan, Chatham, N.J.;  
Stephen H. Wolff, New York, N.Y.

Primary Examiner—George P. Word  
Attorney, Agent, or Firm—Jacobs & Jacobs

[73] Assignee: The Wolff Marketing Group Inc.,  
New York, N.Y.

[57] CLAIM

[\*\*] Term: 14 Years

The ornamental design for a memo pad holder, as shown and described.

[21] Appl. No.: 610,270

DESCRIPTION

[22] Filed: May 14, 1984

[52] U.S. Cl. .... D19/78; D19/83;  
D19/92

[58] Field of Search ..... D19/20, 25, 75-79,  
D19/83, 86-88, 91-92

FIG. 1 is a perspective view of a memo pad holder showing our new design;  
FIG. 2 is a front elevational view;  
FIG. 3 is a rear elevational view;  
FIG. 4 is a left side elevational view;  
FIG. 5 is a right side elevational view;  
FIG. 6 is a top plan view;  
FIG. 7 is a bottom plan view; and  
FIG. 8 is a cross sectional view taken along the lines 8-8 of FIG. 6.

[56] References Cited

U.S. PATENT DOCUMENTS

D. 101,066 9/1936 Richardson ..... D19/78  
D. 188,831 9/1960 Olson ..... D19/92

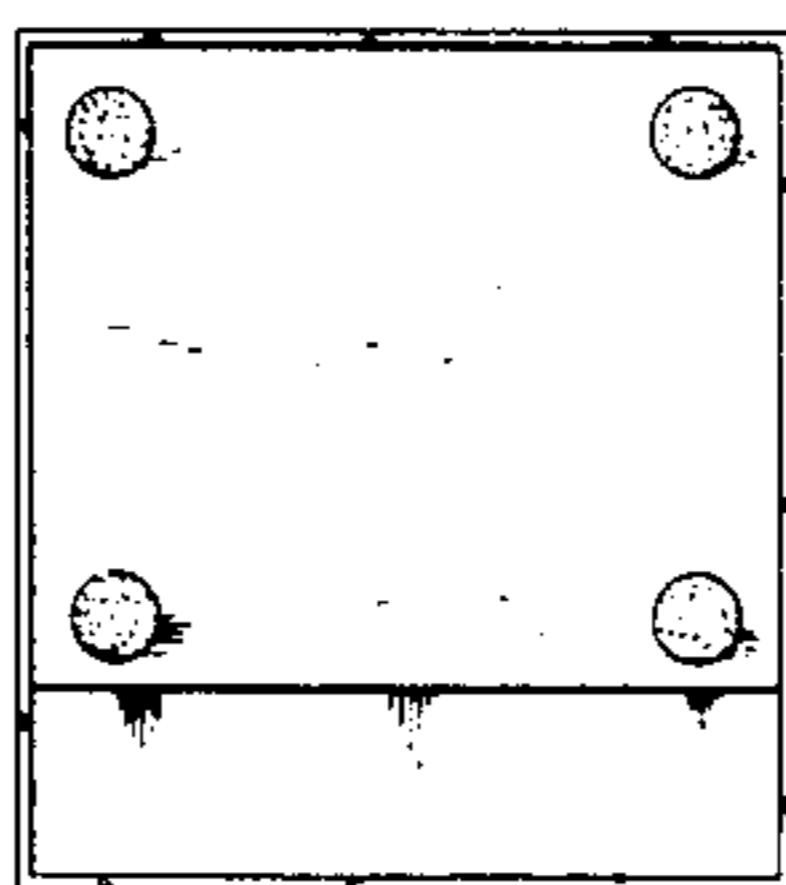
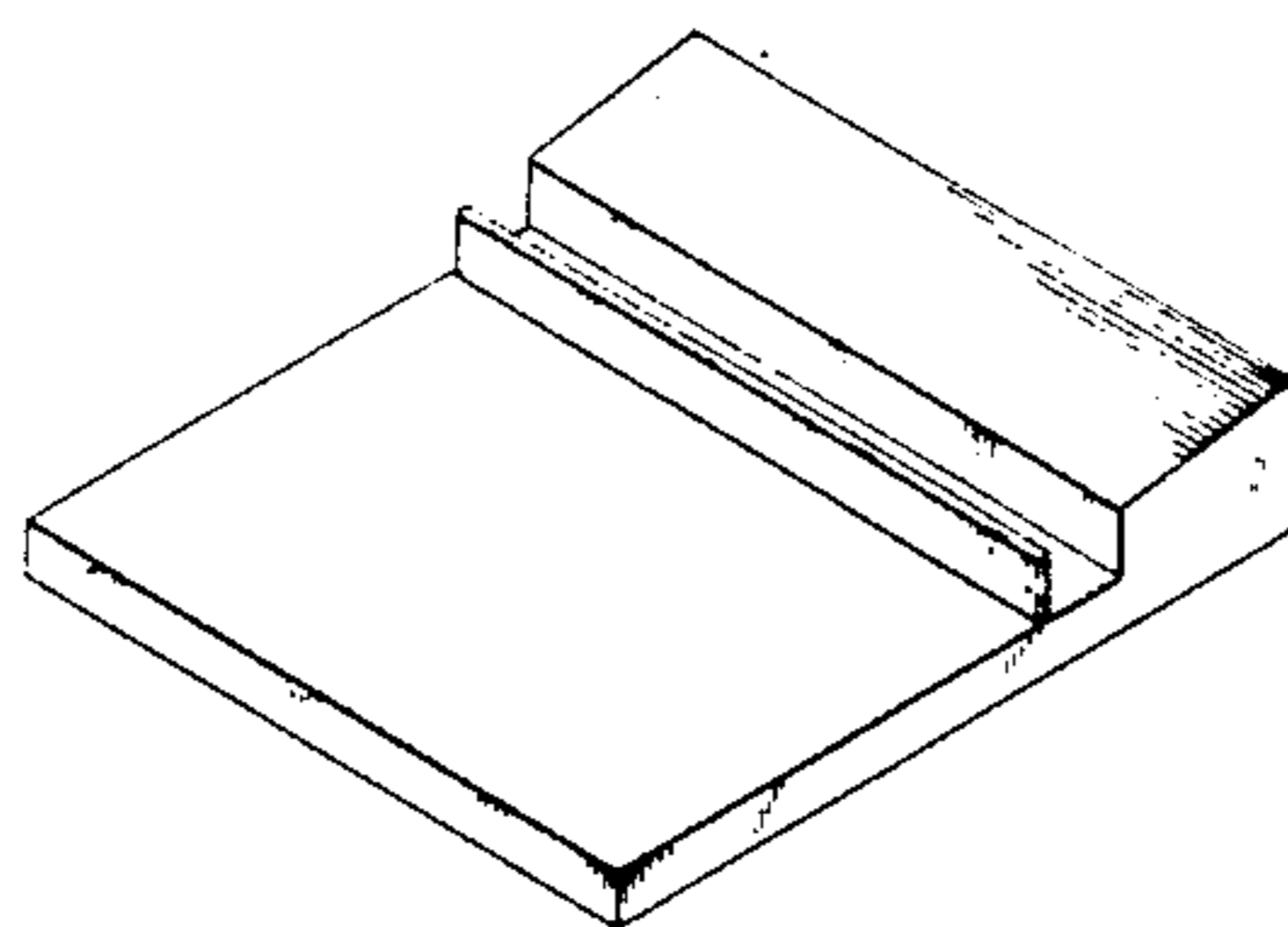

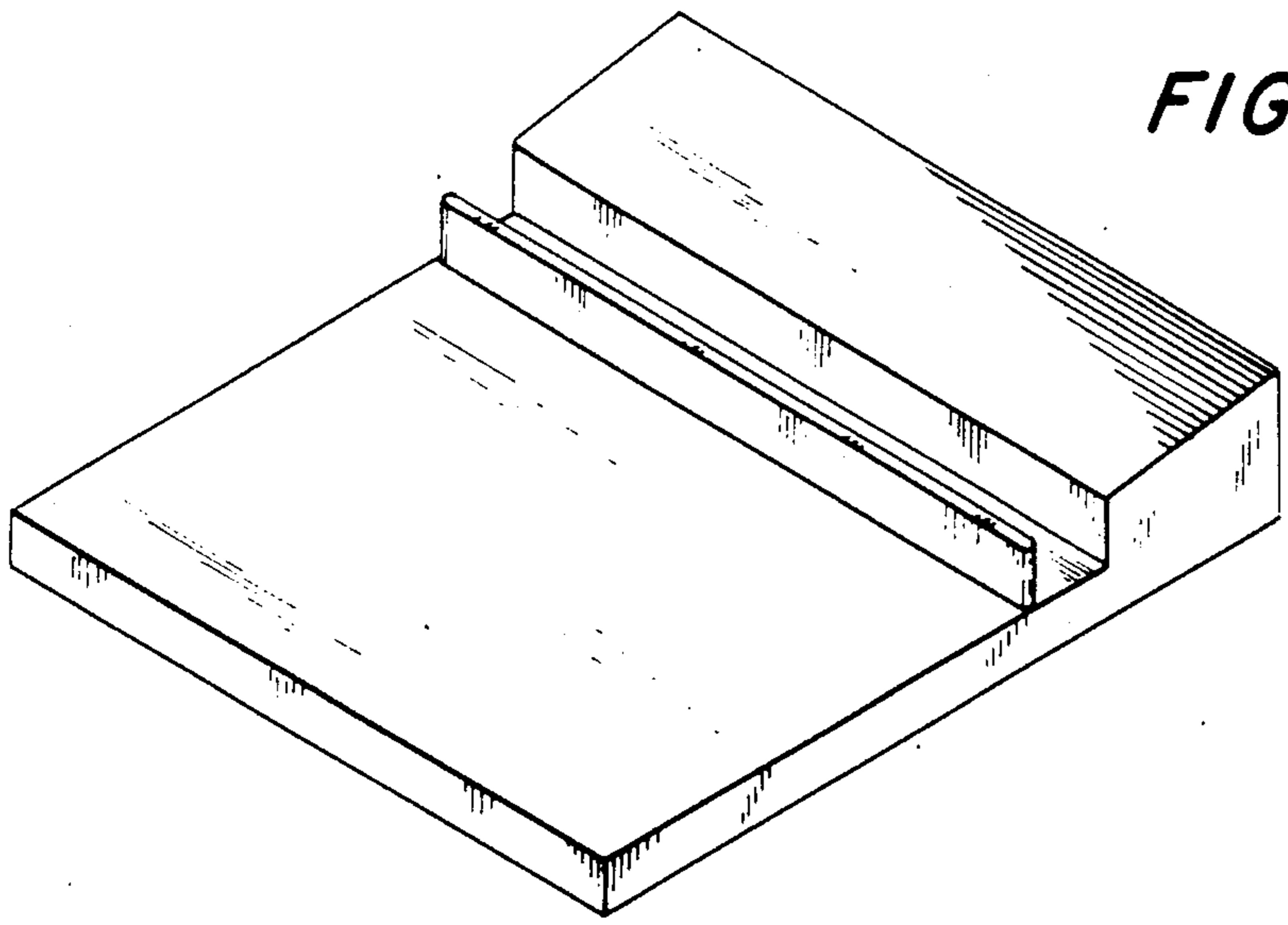

FIG. 1

81 ←

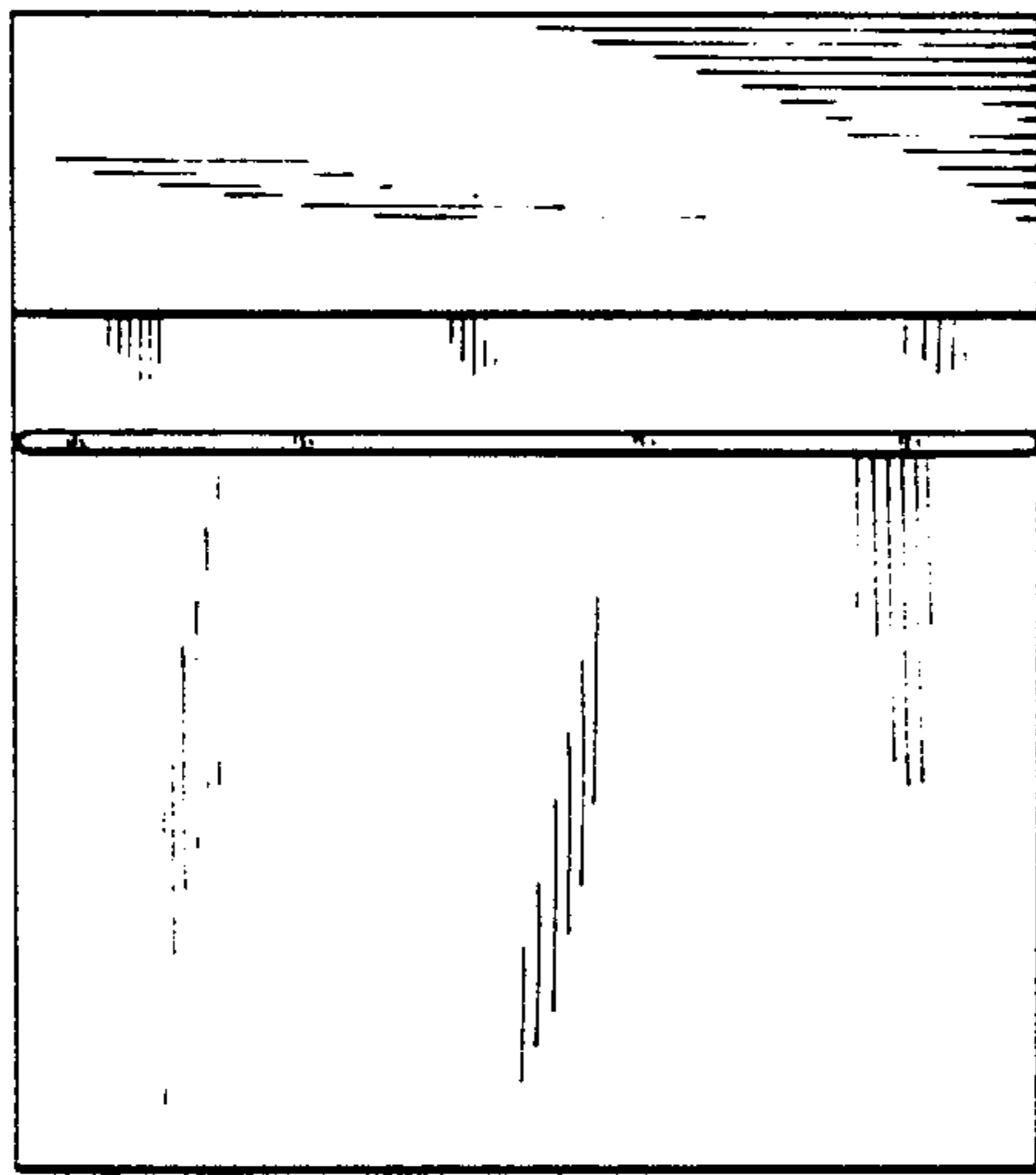

FIG. 6

81 ←

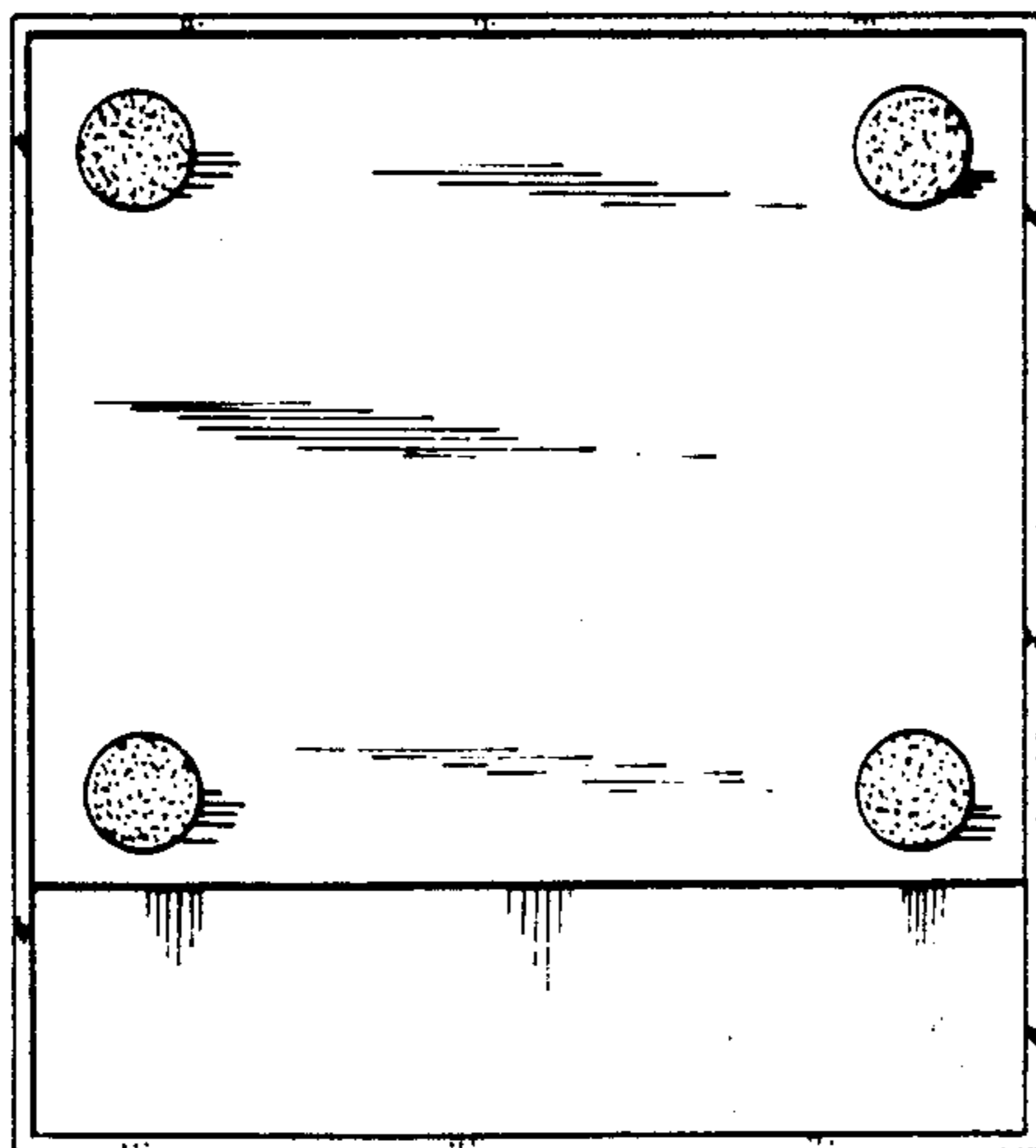
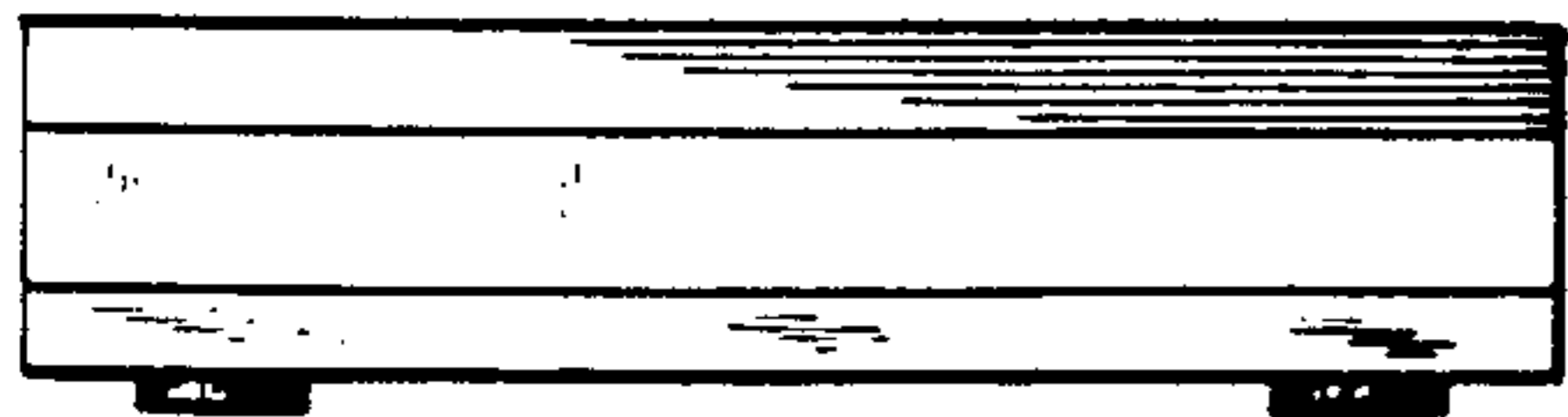
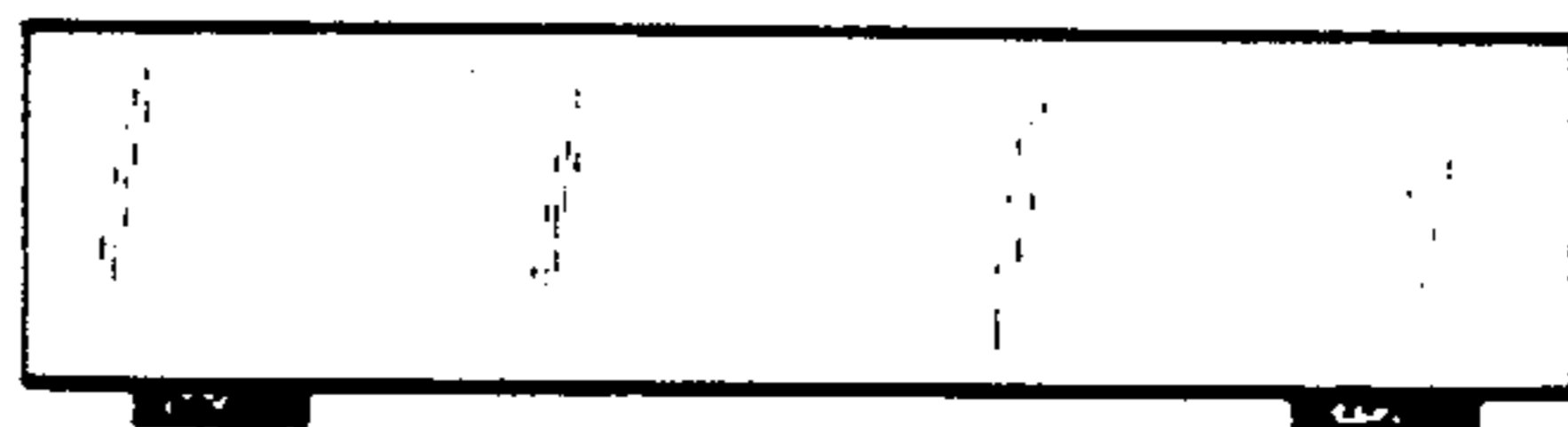

FIG. 7

*FIG. 2*



*FIG. 3*



*FIG. 4*



*FIG. 5*

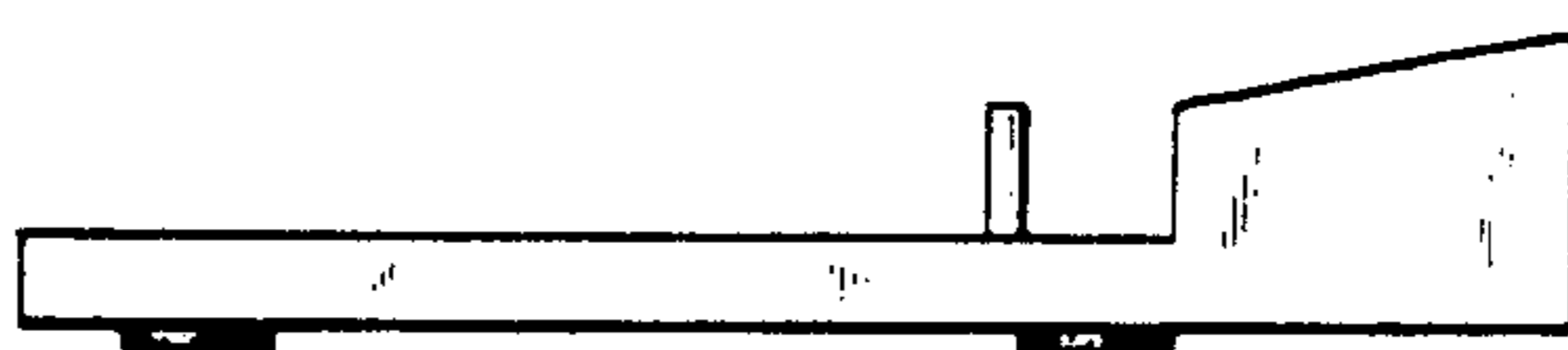

*FIG. 8*

