

**United States Patent** [19]  
**Suzuki et al.**

[11] **Patent Number: Des. 289,990**  
[45] **Date of Patent: \*\* May 26, 1987**

[54] **MOTORBOAT**

[75] **Inventors: Toshiro Suzuki, Kobe; Seiichi Ino, Akashi, both of Japan**

[73] **Assignee: Kawasaki Jukogyo Kabushiki Kaisha, Kobe, Japan**

[\*\*] **Term: 14 Years**

[21] **Appl. No.: 806,551**

[22] **Filed: Nov. 26, 1985**

[30] **Foreign Application Priority Data**

May 27, 1985 [JP] Japan ..... 60-21988  
[52] **U.S. Cl. .... D12/307**  
[58] **Field of Search ..... D12/300, 307, 314, 310; 114/270; 440/38, 87, 88, 89**

[56] **References Cited**

**U.S. PATENT DOCUMENTS**

Re. 30,978 6/1982 Jacobson ..... 440/42

D. 285,678 9/1986 Suzuki et al. .... D12/307  
D. 286,629 11/1986 Suzuki et al. .... D12/307  
4,231,315 11/1980 Tachibana et al. .... 114/121

*Primary Examiner*—James M. Gandy  
*Assistant Examiner*—Kay H. Chin  
*Attorney, Agent, or Firm*—Leydig, Voit & Mayer

[57] **CLAIM**

The ornamental design for a motorboat, as shown and described.

**DESCRIPTION**

FIG. 1 is a front elevational view of a motorboat showing our new design;  
FIG. 2 is a top plan view thereof;  
FIG. 3 is a right side elevational view thereof;  
FIG. 4 is a left side elevational view thereof;  
FIG. 5 is a rear elevational view thereof;  
FIG. 6 is a bottom plan view thereof;  
FIG. 7 is a top perspective view thereof; and  
FIG. 8 is a top perspective view thereof, with the hand-lever lifted up.

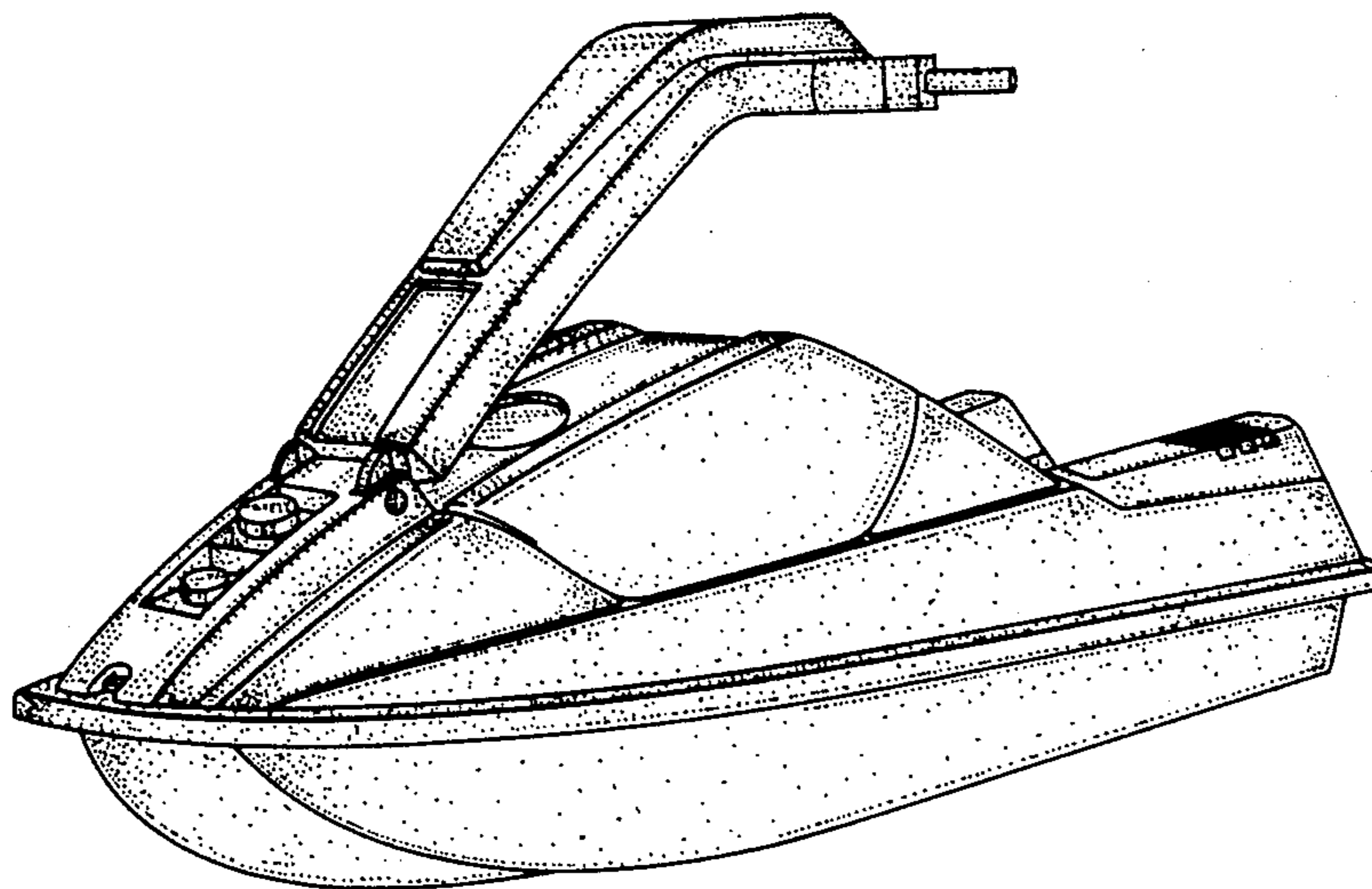

FIG. 1

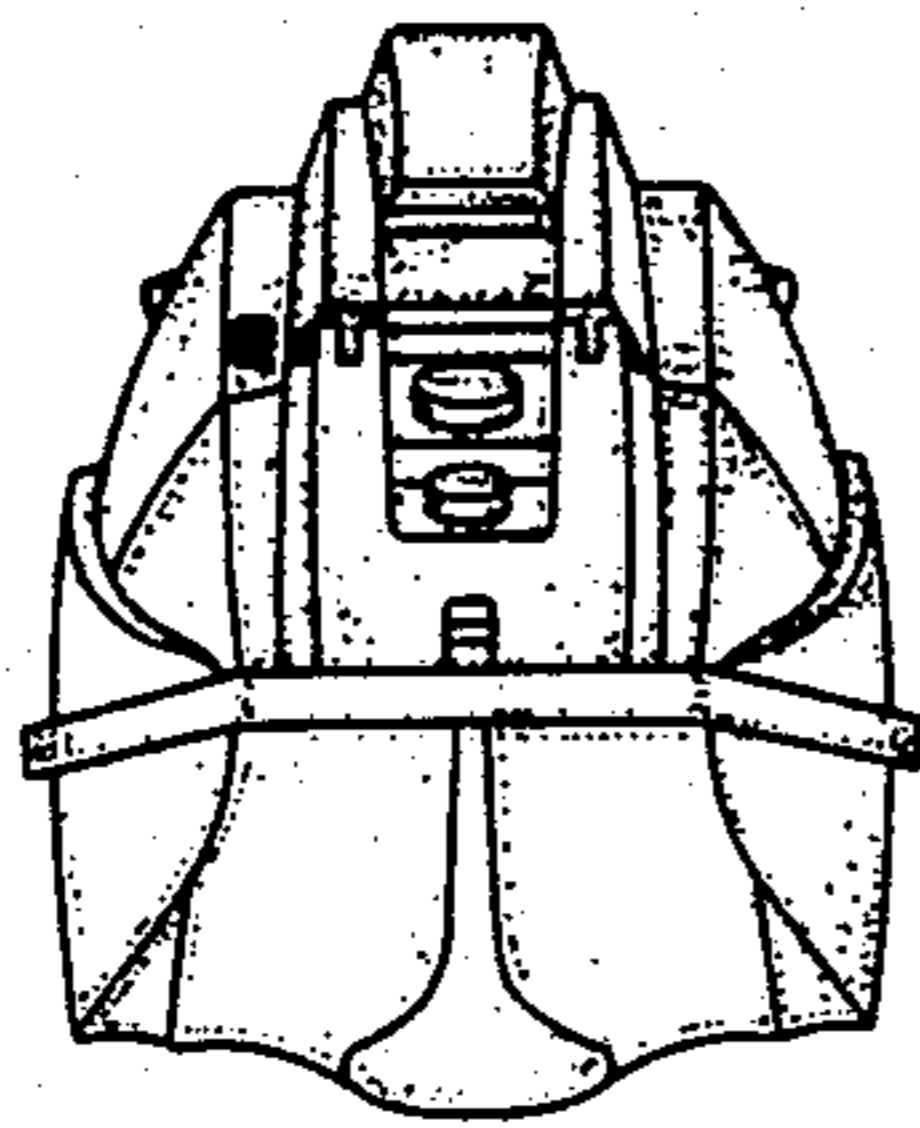

FIG. 2

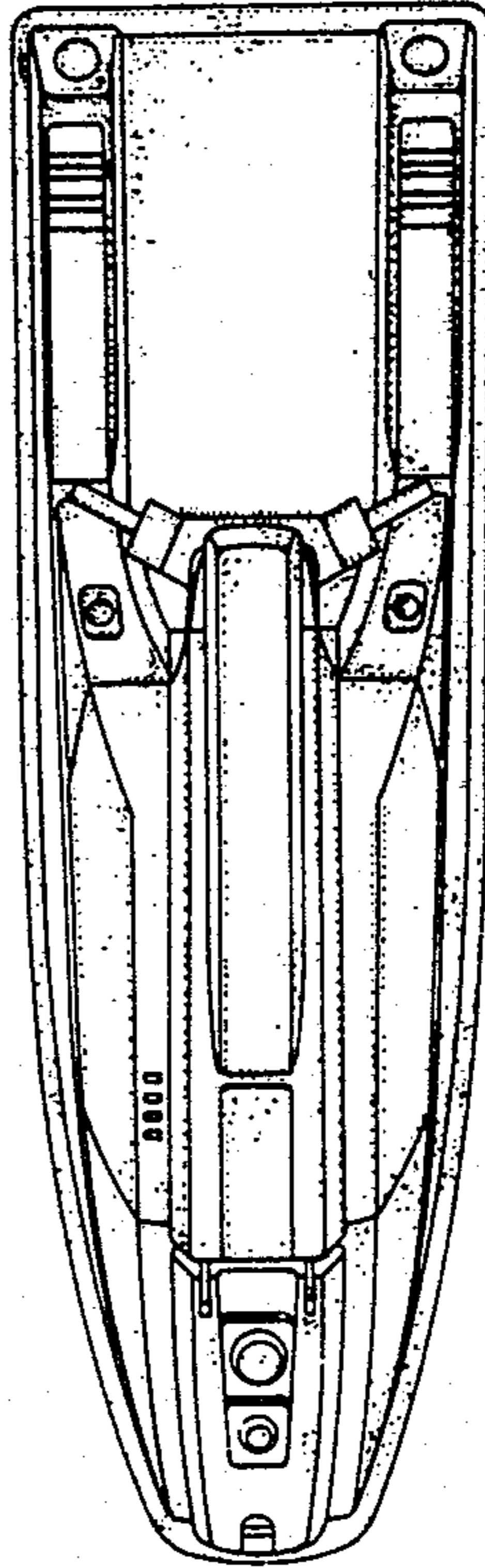

FIG. 3

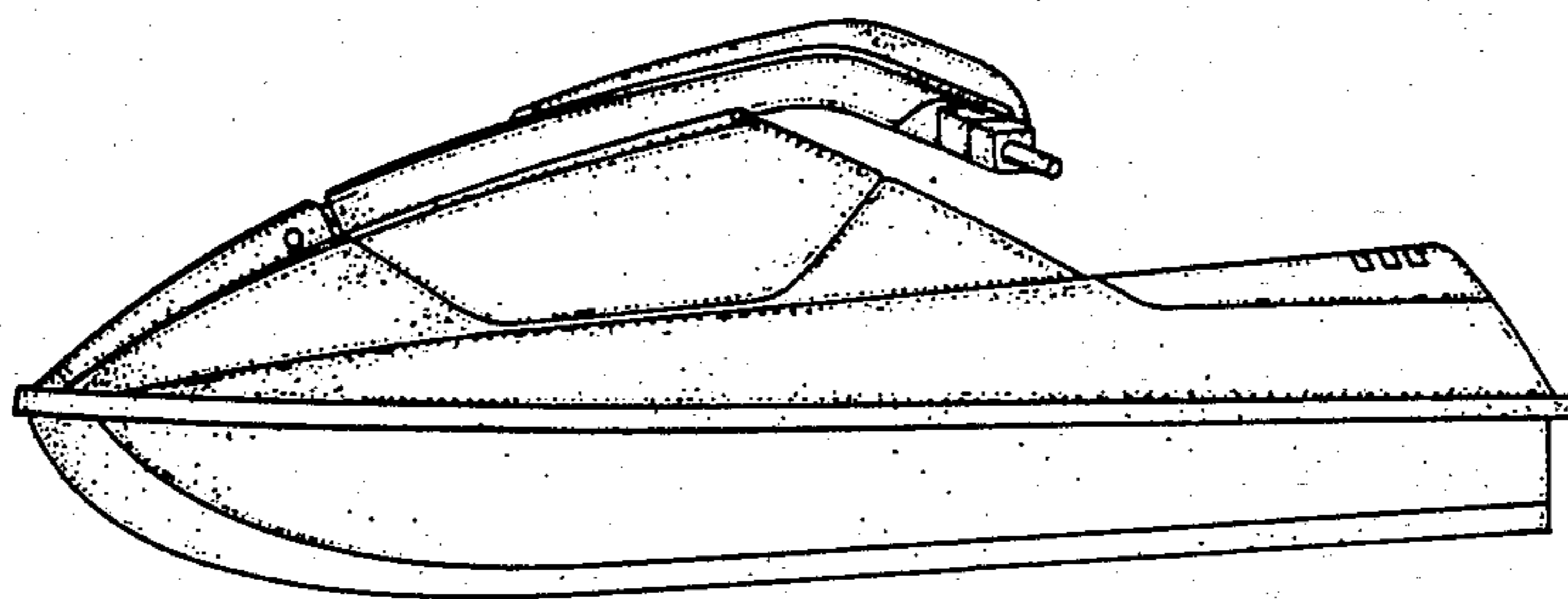

FIG. 4

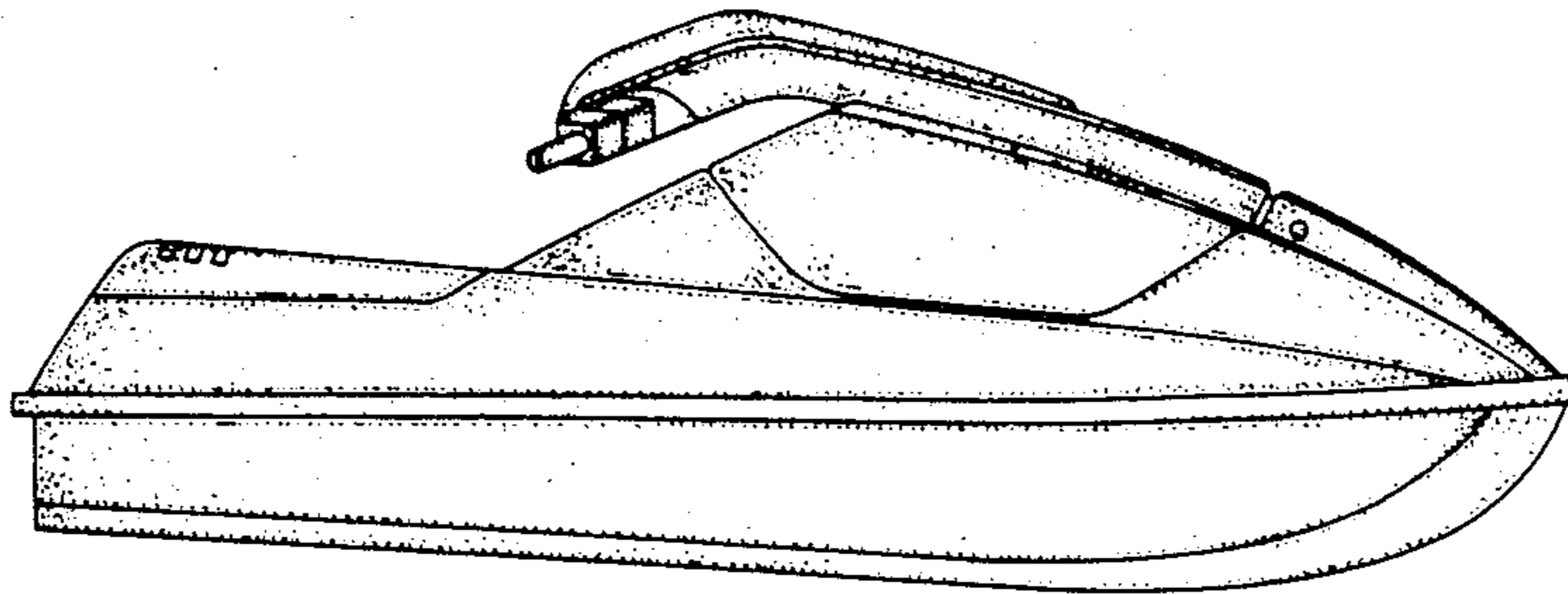

FIG. 6

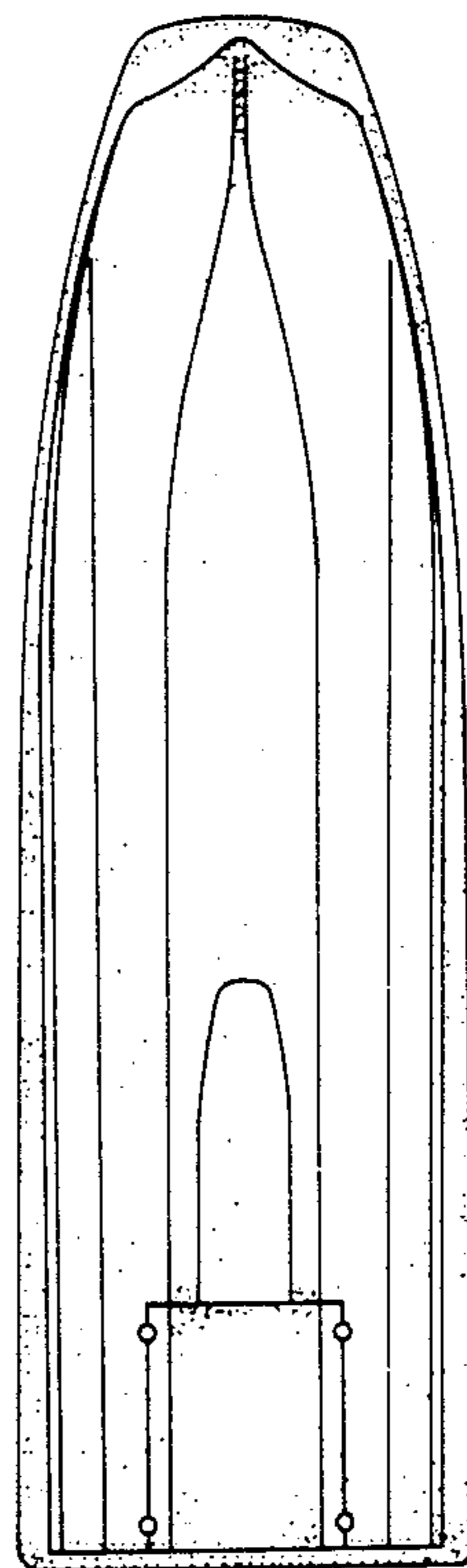

FIG. 5

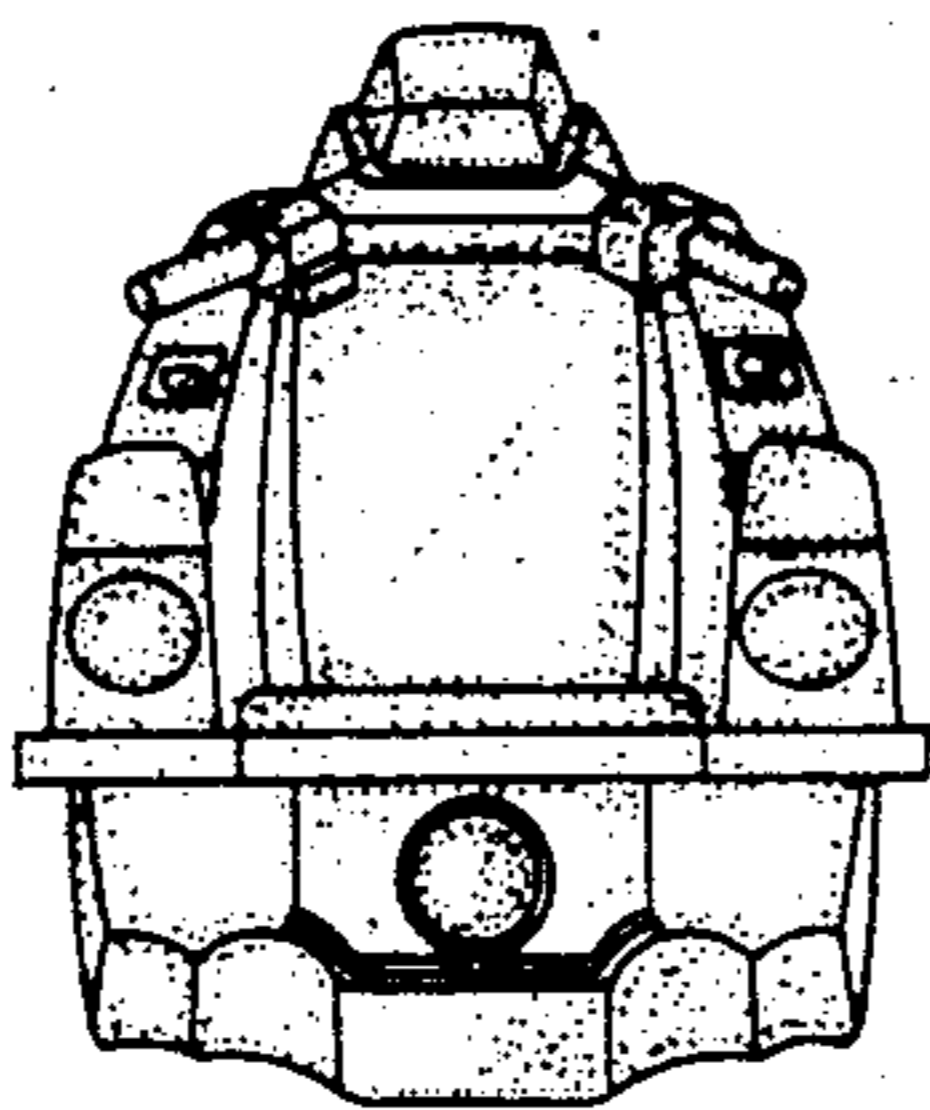

FIG. 7

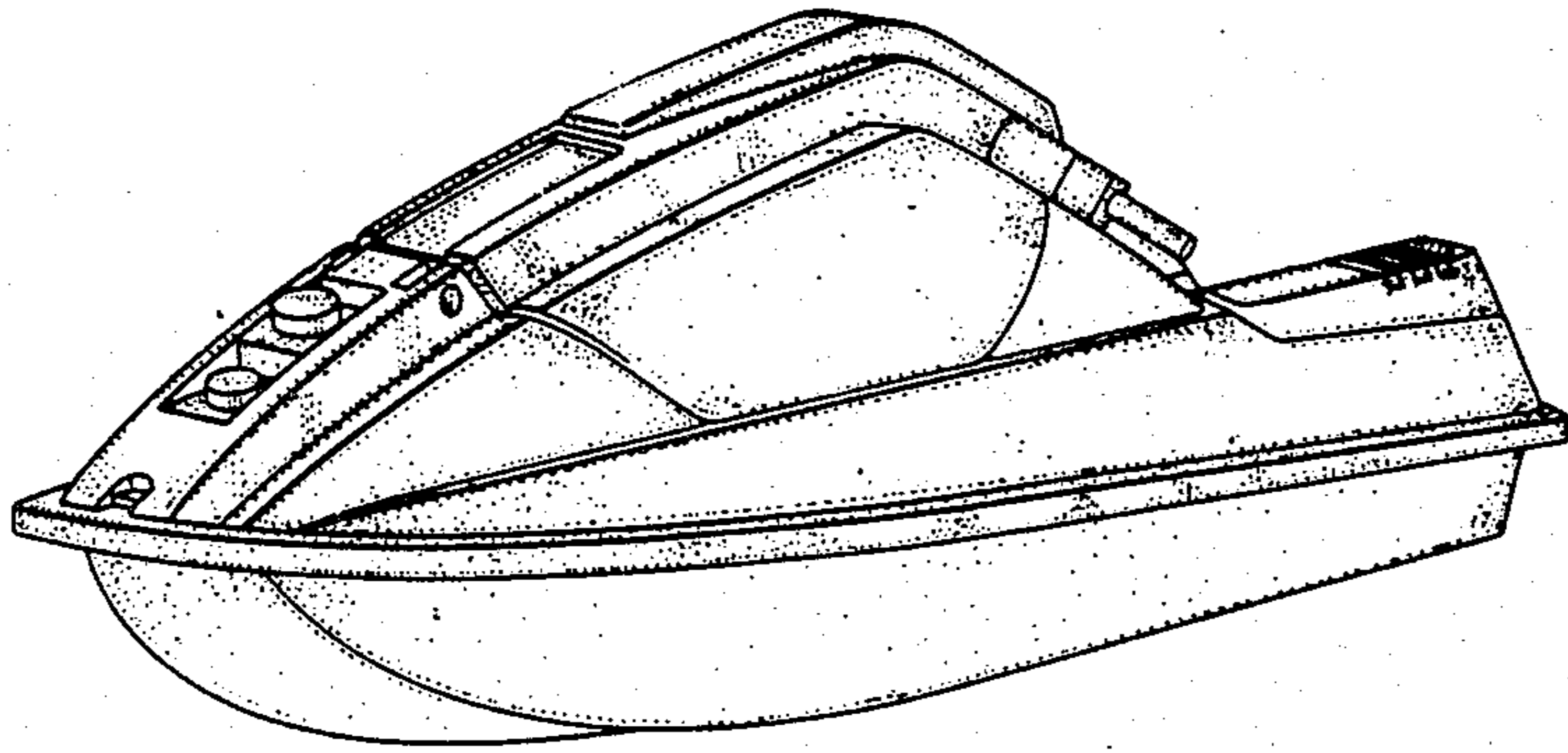

FIG. 8

