

United States Patent [19]

Ishikura et al.

[11] Patent Number: **Des. 289,984**

[45] Date of Patent: **** May 26, 1987**

[54] **TROLLEY BUS BAR**

[75] Inventors: **Takashi Ishikura; Joji Mino; Takaaki Nagato**, all of Osaka, Japan

[73] Assignee: **Tsubakimoto Chain Co.**, Osaka, Japan

[**] Term: **14 Years**

[21] Appl. No.: **639,963**

[22] Filed: **Aug. 10, 1984**

[52] U.S. Cl. **D12/50**

[58] Field of Search **D12/49, 50, 42; 104/93, 104/110, 191, 45 A; D25/74**

[56] **References Cited**

U.S. PATENT DOCUMENTS

D. 278,229	4/1985	Widell et al.	D13/12
4,393,785	7/1983	Hörtnagel	104/93
4,520,733	6/1985	Willmann	104/110

Primary Examiner—Wallace R. Burke
Assistant Examiner—Kay H. Chin
Attorney, Agent, or Firm—Flynn, Thiel, Boutell & Tanis

[57] CLAIM

The ornamental design for a trolley bus bar, as shown and described.

DESCRIPTION

FIG. 1 is a front elevational view of a trolley bus bar showing our design;
FIG. 2 is a rear elevational view thereof;
FIG. 3 is a top plan view thereof;
FIG. 4 is a bottom plan view thereof;
FIG. 5 is a right side elevational view thereof;
FIG. 6 is a left side elevational view thereof; and
FIG. 7 is a perspective view thereof.
The trolley bus bar in FIGS. 1 through 4 is shown broken away in the center for convenience of illustration.

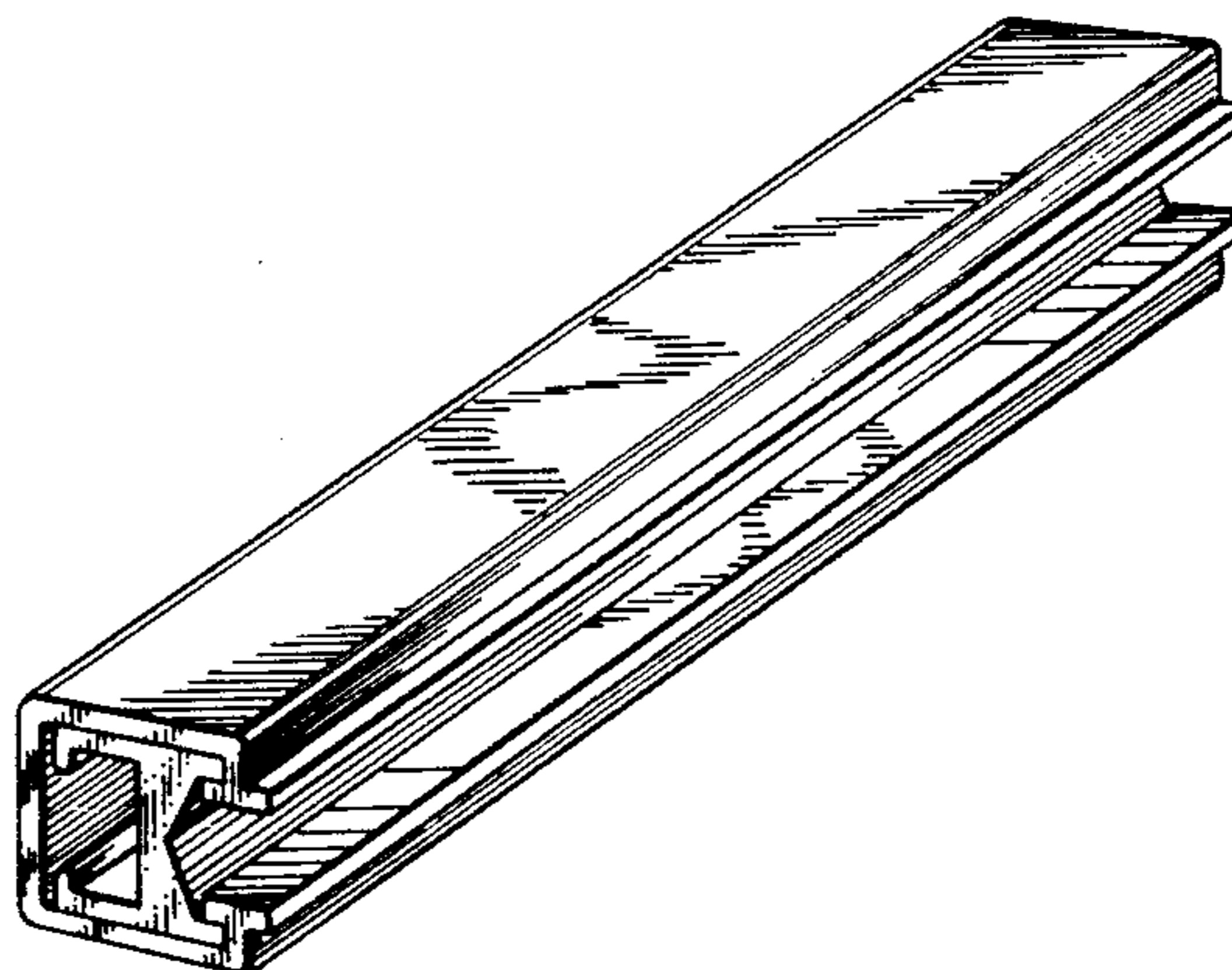

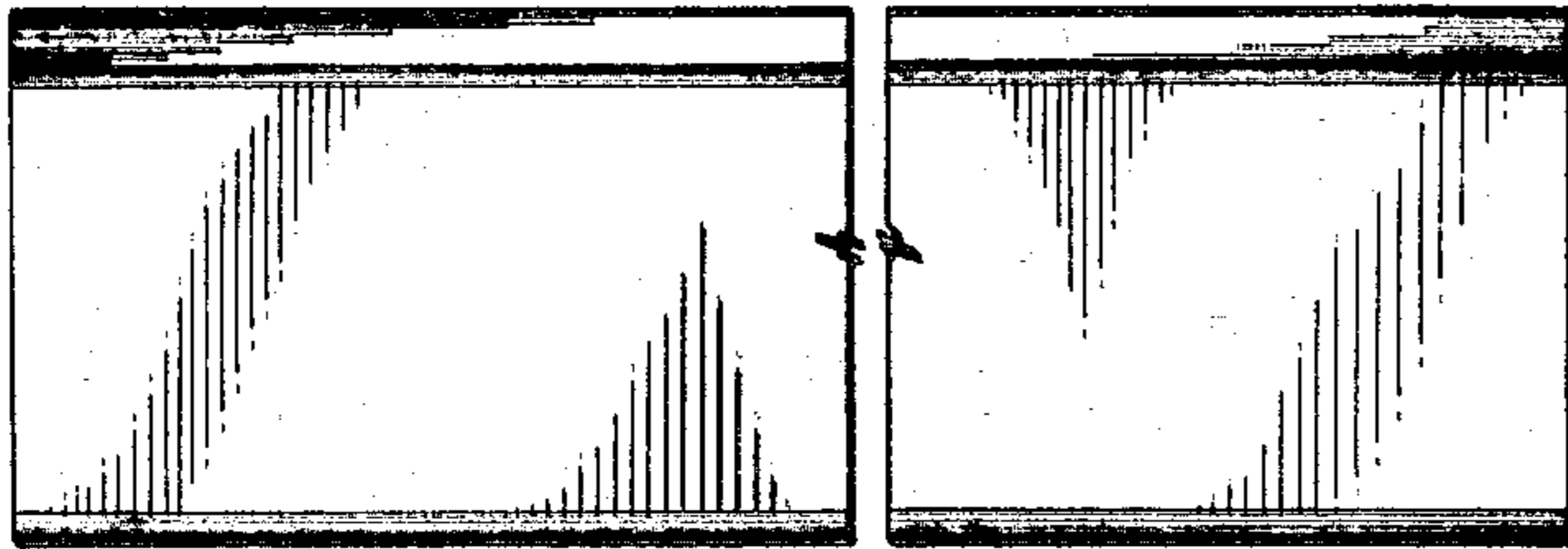
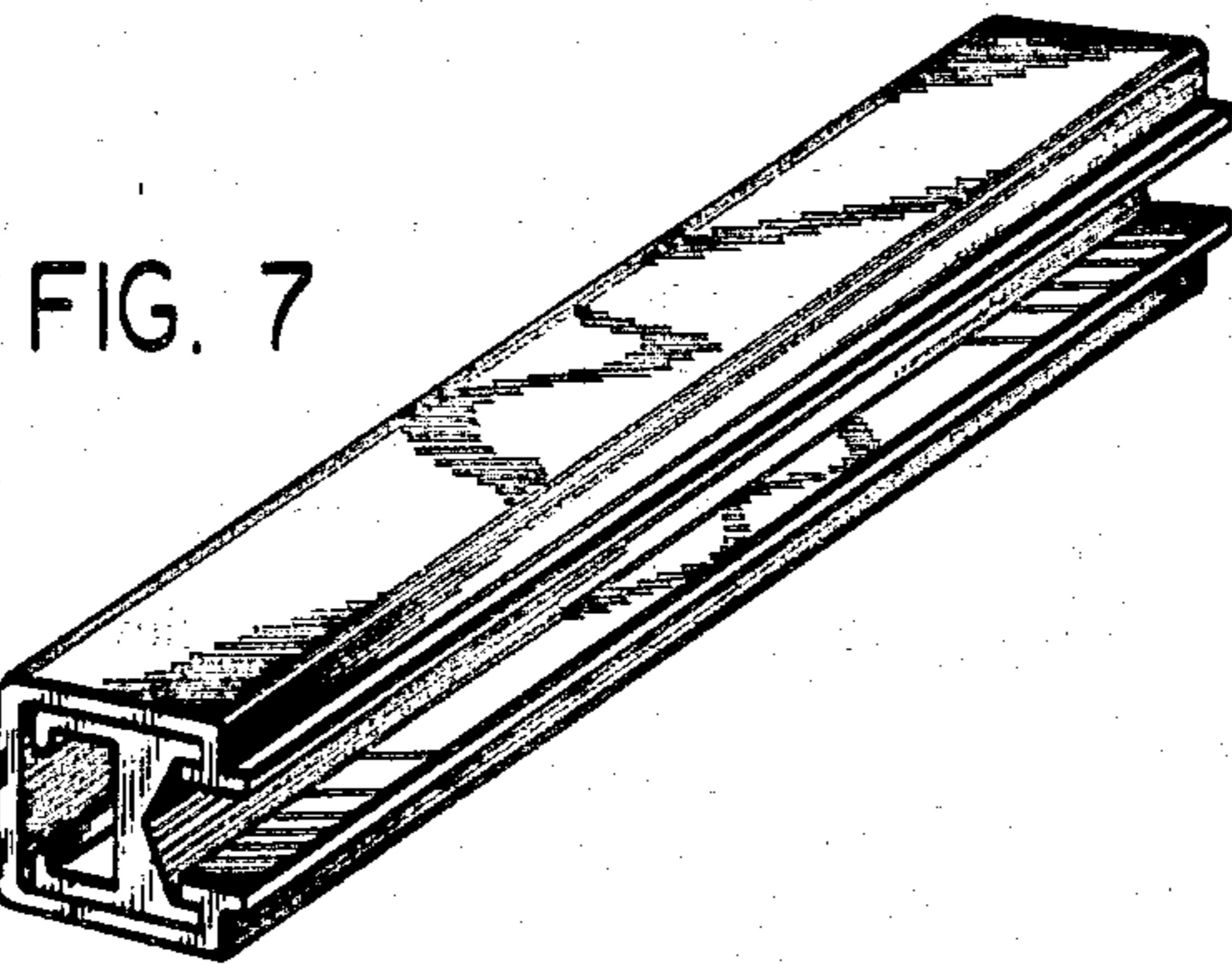

FIG. 4

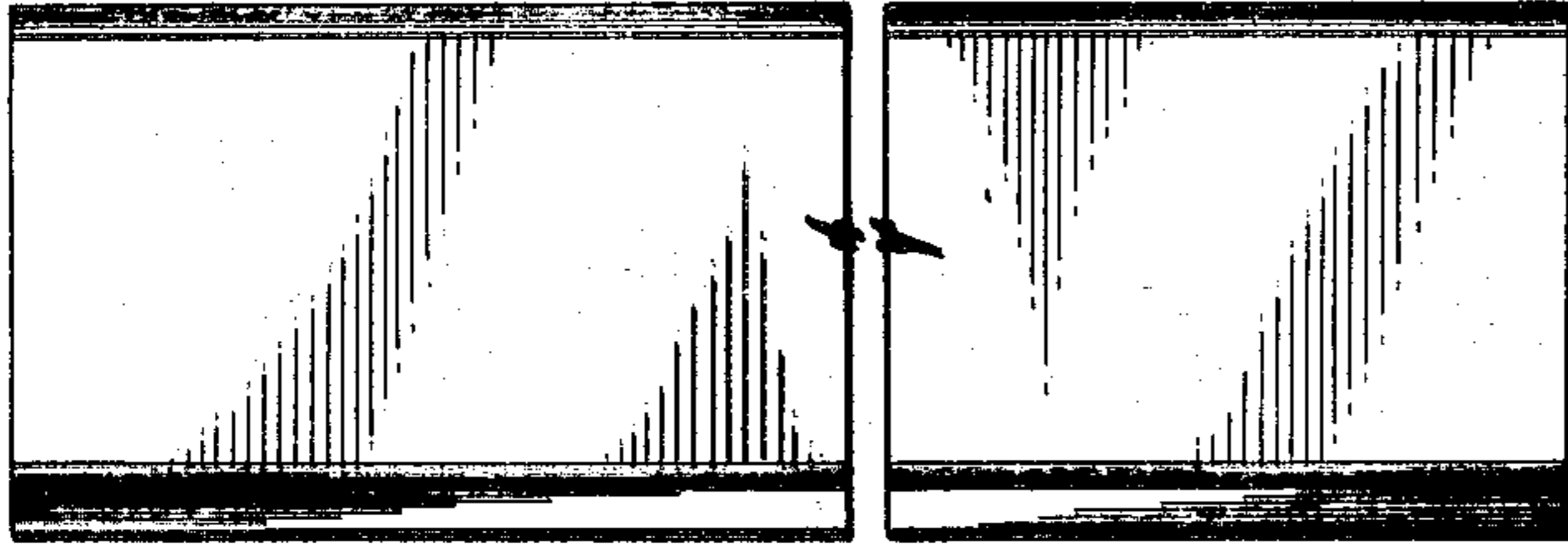

FIG. 3

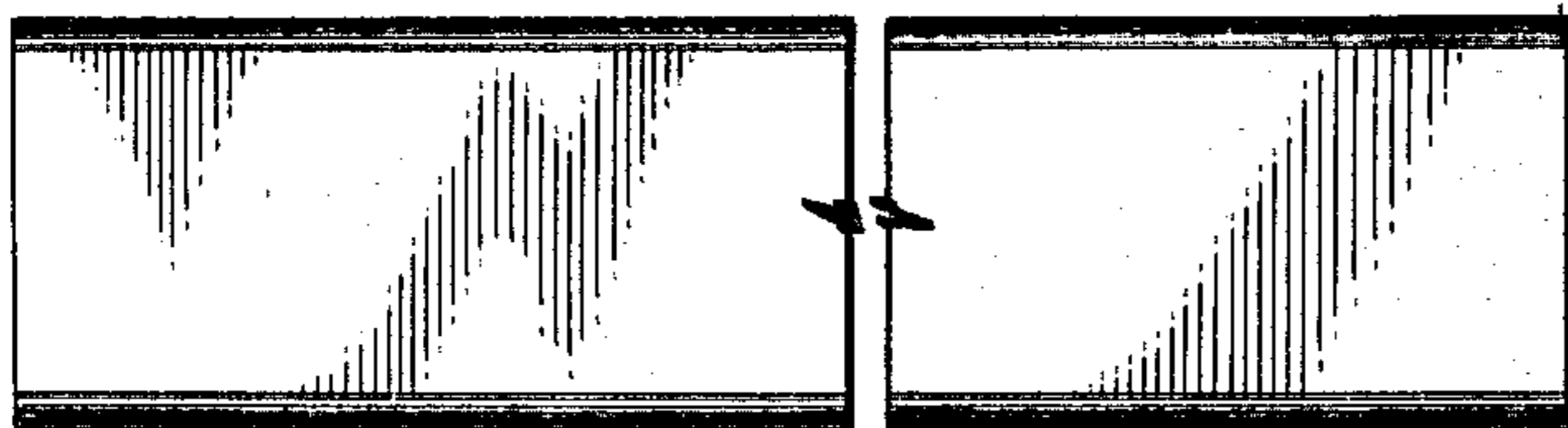

FIG. 2

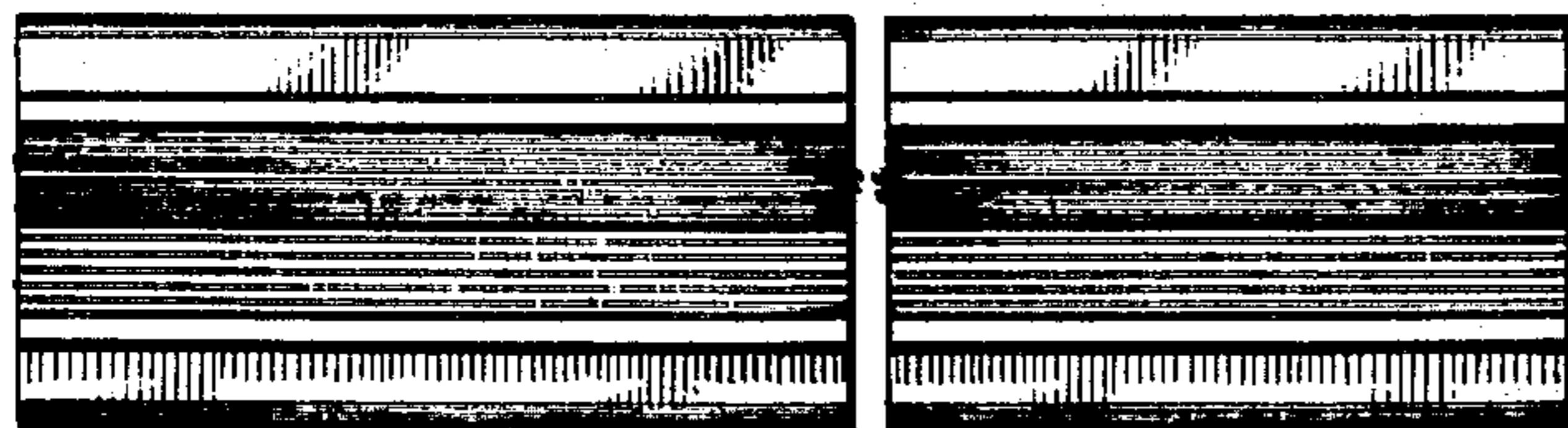

FIG. 1

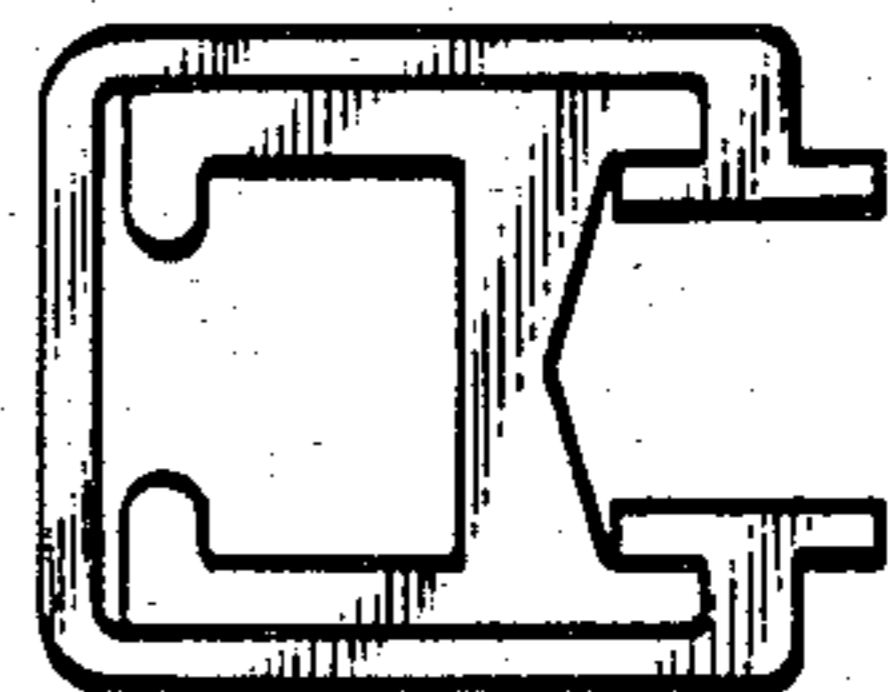

FIG. 6

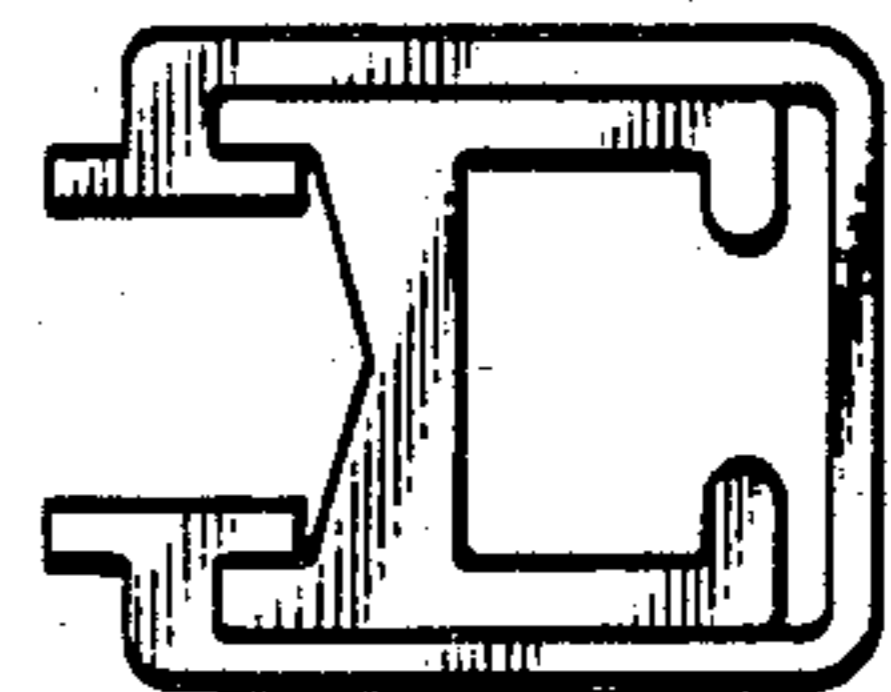

FIG. 5