

- [54] TRIGGER ACTUATED GLUE GUN
- [75] Inventor: Robert I. Somers, Raleigh, N.C.
- [73] Assignee: Black & Decker, Inc., Towson, Md.
- [**] Term: 14 Years
- [21] Appl. No.: 659,560
- [22] Filed: Apr. 2, 1984
- [52] U.S. Cl. D8/68; D8/14.1; D8/30
- [58] Field of Search D8/14.1, 30, 61, 68; D15/144; 222/146.2, 146.5

Literature showing Swingline Glue Gun.
 Dremel Form No. 15067 22 183/40M showing Pro--
 Bonder Glue Gun.
 Ad Tech publication dated May 1982 and showing
 Pro-90 Glue Gun.
 Photographs of two models of Bostik Thermagrip Glue
 Gun.
 3M brochure on Polygun AE Applicator (Z-A-
 EFR(715)MP).
 Power Adhesive Machines, Inc. brochure on PAM 100
 Hot Melt Adhesive Gun.

Primary Examiner—Susan J. Lucas
Assistant Examiner—C. E. Heflin
Attorney, Agent, or Firm—Finnegan, Henderson,
 Farabow, Garrett & Dunner

[56] **References Cited**
U.S. PATENT DOCUMENTS

D. 226,750	4/1973	Grossman	D8/30
D. 281,391	11/1985	Somers	D8/61
2,995,159	8/1961	Berggren	222/146.5 X
3,314,574	4/1967	Longval et al.	222/146.5
4,378,076	3/1983	Stirnweiss	222/146.5

[57] **CLAIM**

The ornamental design of a trigger actuated glue gun, as shown and described.

DESCRIPTION

FIG. 1 is a right side elevational view of the trigger actuated glue gun showing my new design;
 FIG. 2 is a left side elevational view thereof;
 FIG. 3 is a top plan view thereof;
 FIG. 4 is a bottom plan view thereof;
 FIG. 5 is an end elevational view thereof;
 FIG. 6 is an opposite end elevational view thereof.
 FIG. 7 is a perspective view thereof.

OTHER PUBLICATIONS
 Literature showing Black & Decker Glue Gun.
 Literature showing Steinel Glue Fix 2000.
 3M Publication No. 2-PTCF(335)DPI showing Polygun TC Glue Gun.
 Literature showing Klebe-Colt Glue Gun.
 Literature showing Klebe Pistolen Glue Gun.

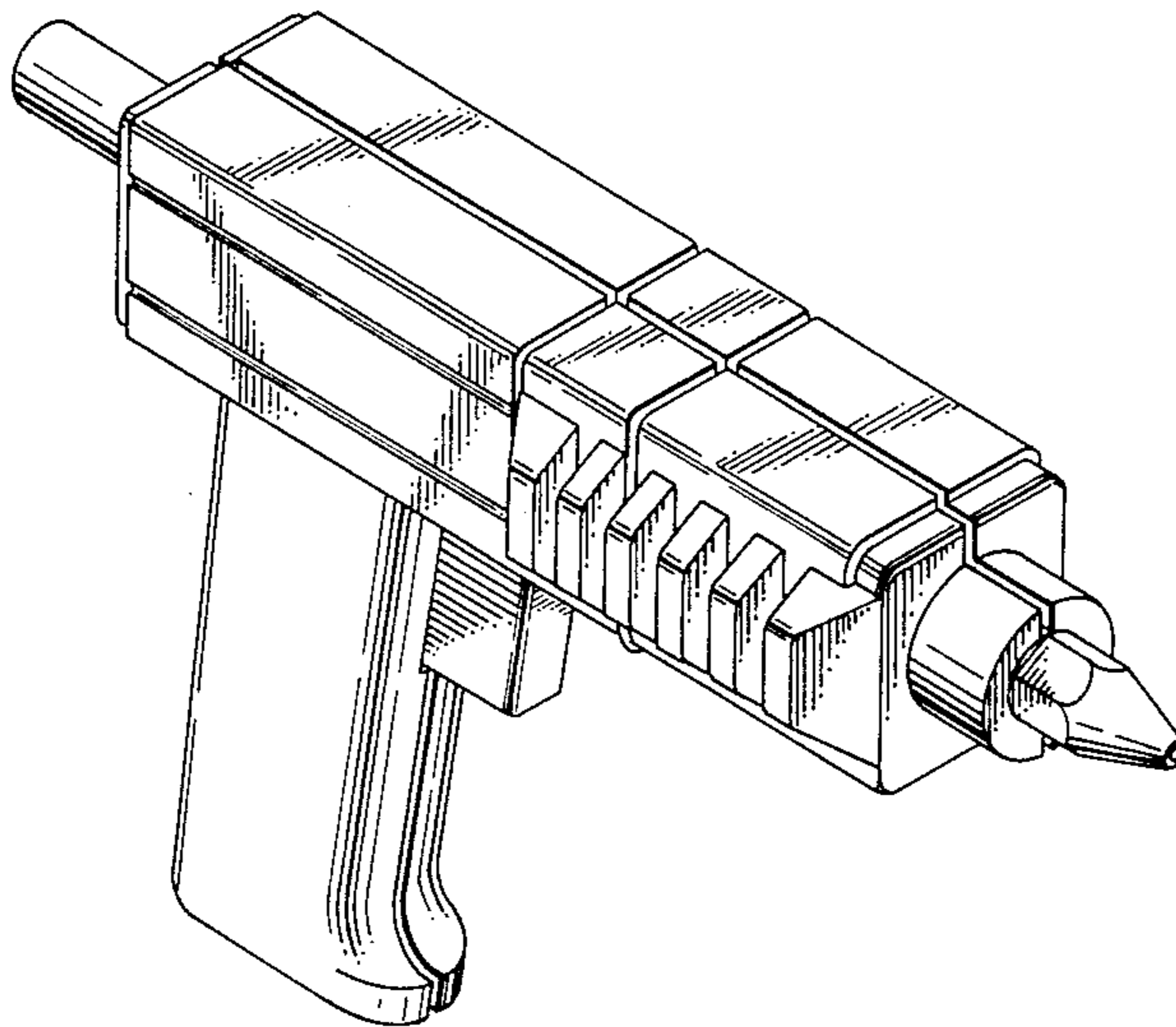

FIG. 1

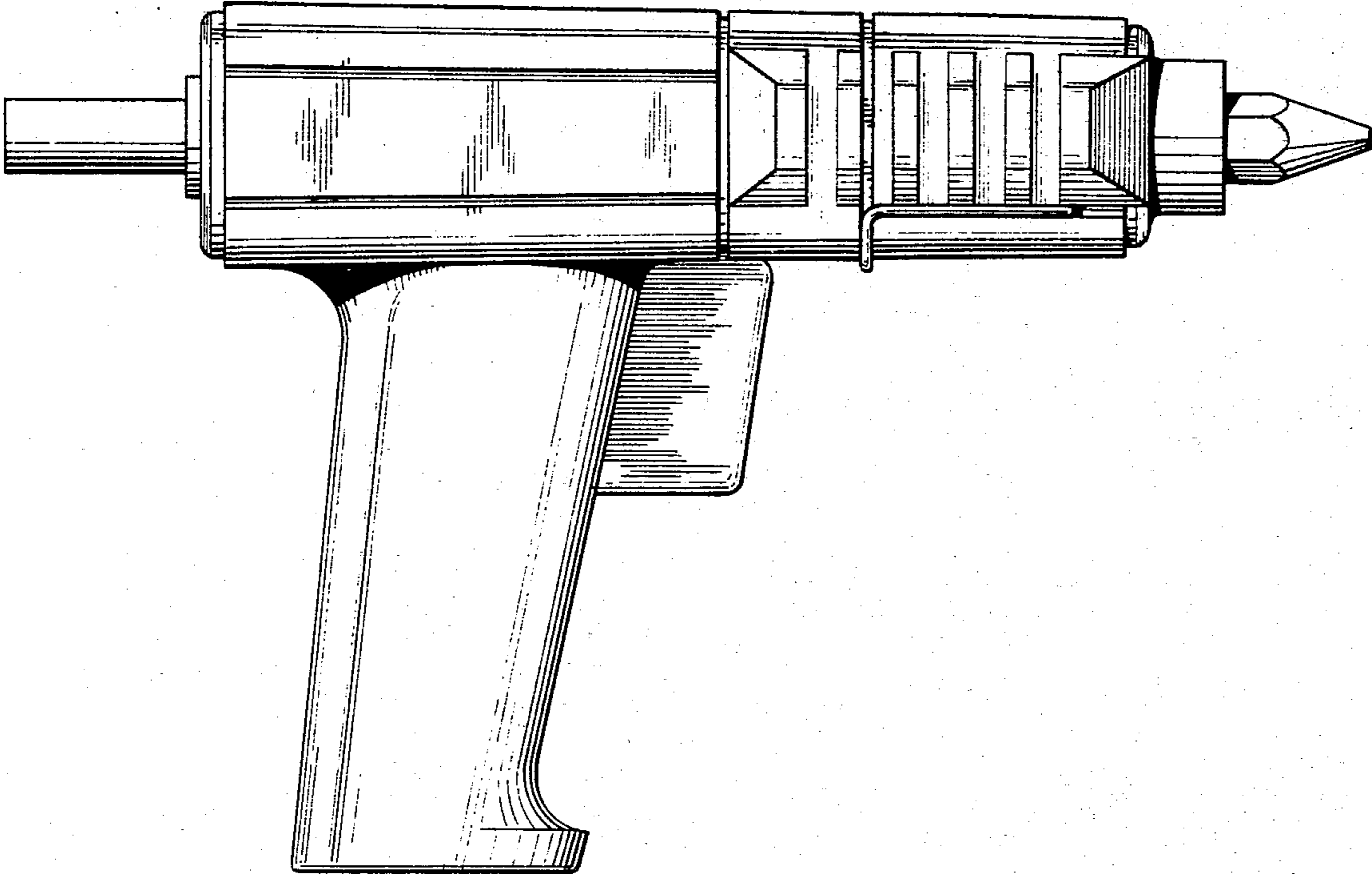

FIG. 2

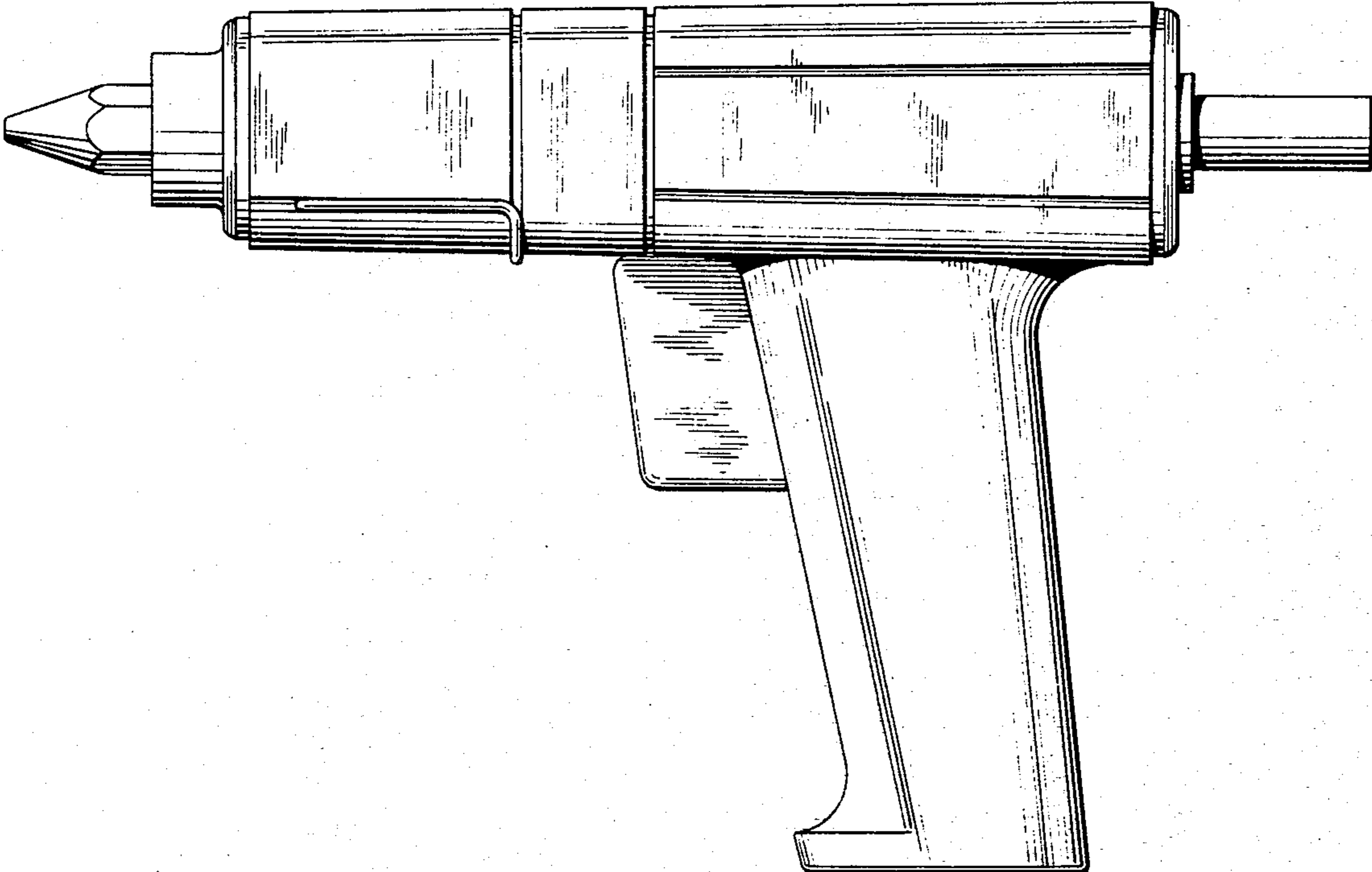

Fig. 3

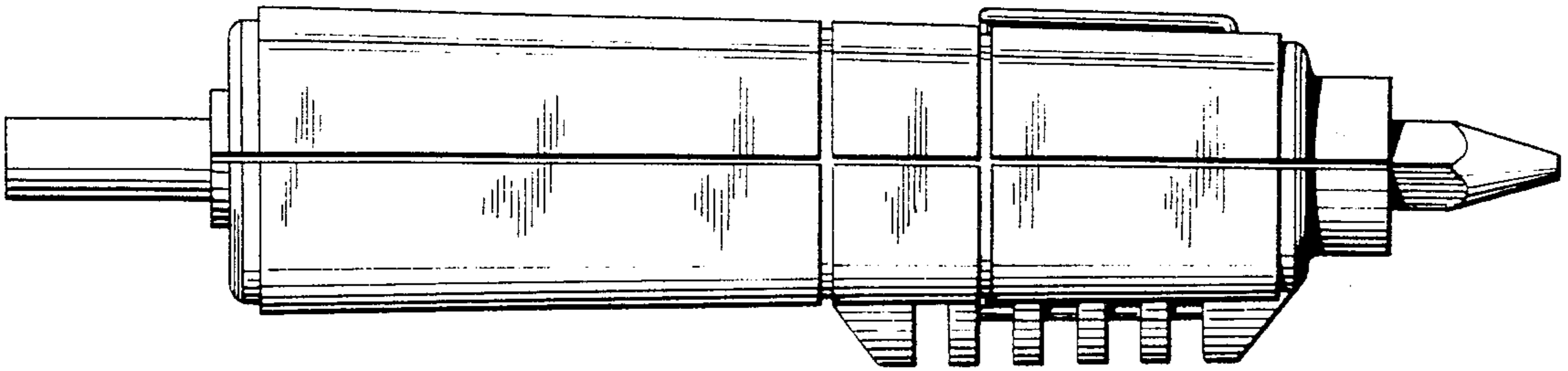

Fig. 4

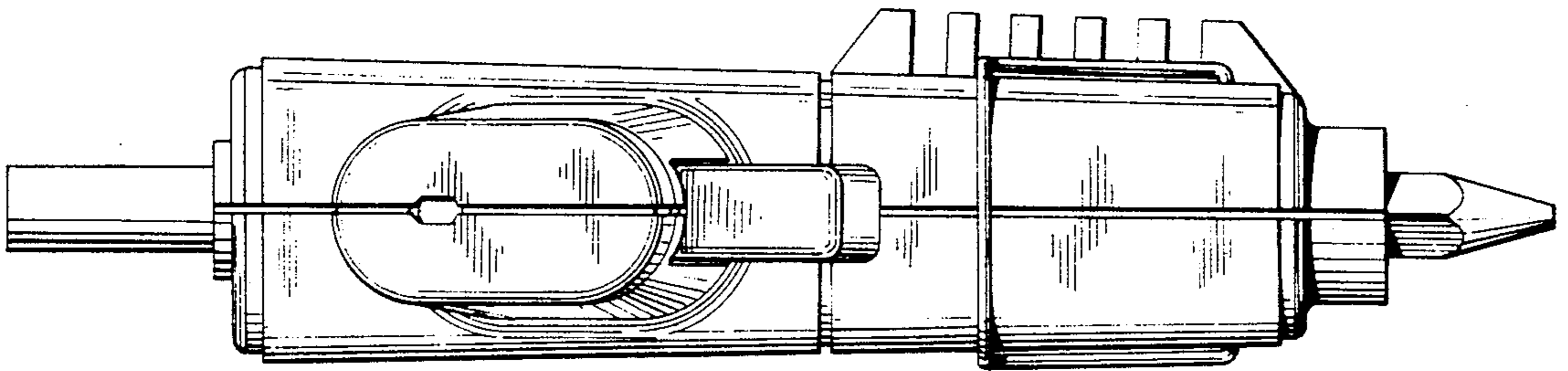

Fig. 5

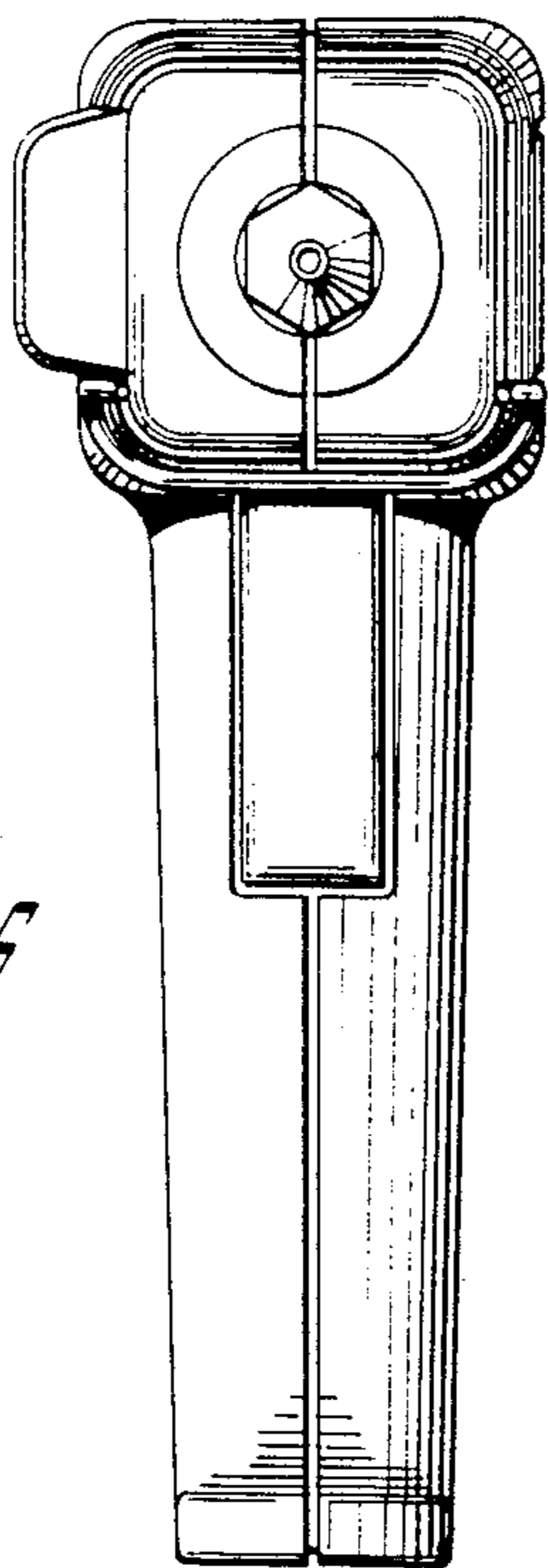

Fig. 6

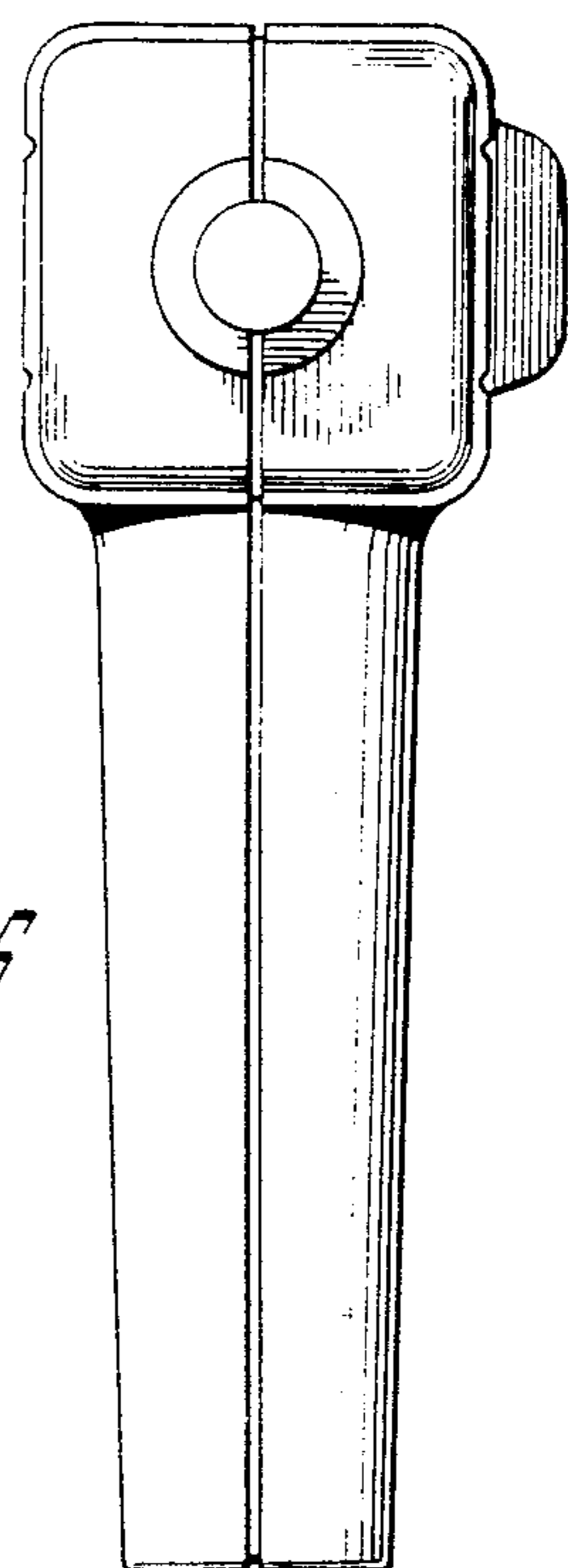
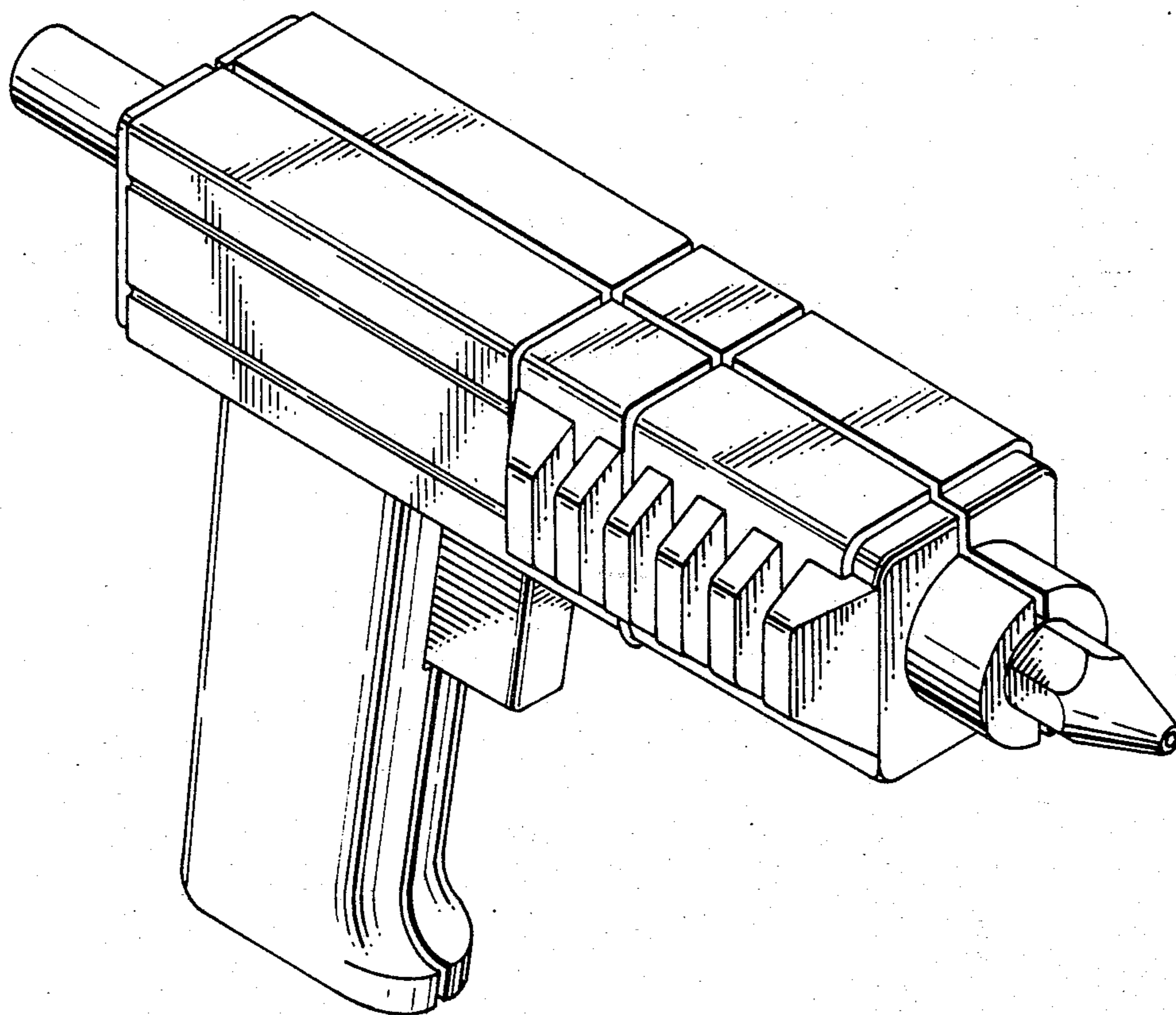

Fig. 7



UNITED STATES PATENT AND TRADEMARK OFFICE
CERTIFICATE OF CORRECTION

PATENT NO. : Des. 289,968
DATED : May 26, 1987
INVENTOR(S) : Robert I. Somers

It is certified that error appears in the above-identified patent and that said Letters Patent is hereby corrected as shown below:

Title page:

Change the serial number from "659,560" to --595,603--.

**Signed and Sealed this
Third Day of November, 1987**

Attest:

Attesting Officer

DONALD J. QUIGG

Commissioner of Patents and Trademarks