

[54] **PORTABLE LAMP HOUSING**
[75] **Inventor: Alastair F. Langlands, Normandy, England**

[73] **Assignee: Briticent International Limited, Ringwood, England**

[**] **Term: 14 Years**

[21] **Appl. No.: 613,201**

[22] **Filed: May 23, 1984**

[30] **Foreign Application Priority Data**

Dec. 1, 1983 [GB] United Kingdom 1016634
[52] **U.S. Cl. D26/37; D26/60**
[58] **Field of Search D26/24, 60, 37-50; 362/157, 158, 183-208, 396**

[56] **References Cited**

U.S. PATENT DOCUMENTS

D. 141,063 5/1945 Kiplock D26/60
D. 199,157 9/1964 Aneshansley D26/45 X

1,494,596 5/1924 Erwin 362/396 X
2,465,519 3/1949 Eastman 362/396
3,792,230 2/1974 Ray D26/45 X
4,307,439 12/1981 Sassmannshausen 362/186

FOREIGN PATENT DOCUMENTS

818001 8/1959 United Kingdom 362/396

Primary Examiner—Susan J. Lucas
Attorney, Agent, or Firm—Fleit, Jacobson, Cohn & Price

[57] **CLAIM**

The ornamental design for a portable lamp housing, as shown and described.

DESCRIPTION

FIG. 1 is a side perspective view of the portable lamp housing showing my new design;
FIG. 2 is a perspective view from the other side thereof;
FIG. 3 is a front elevation thereof; and
FIG. 4 is a rear elevation thereof.

The broken lines are shown in FIGS. 1 through 4 for illustrative purposes only.

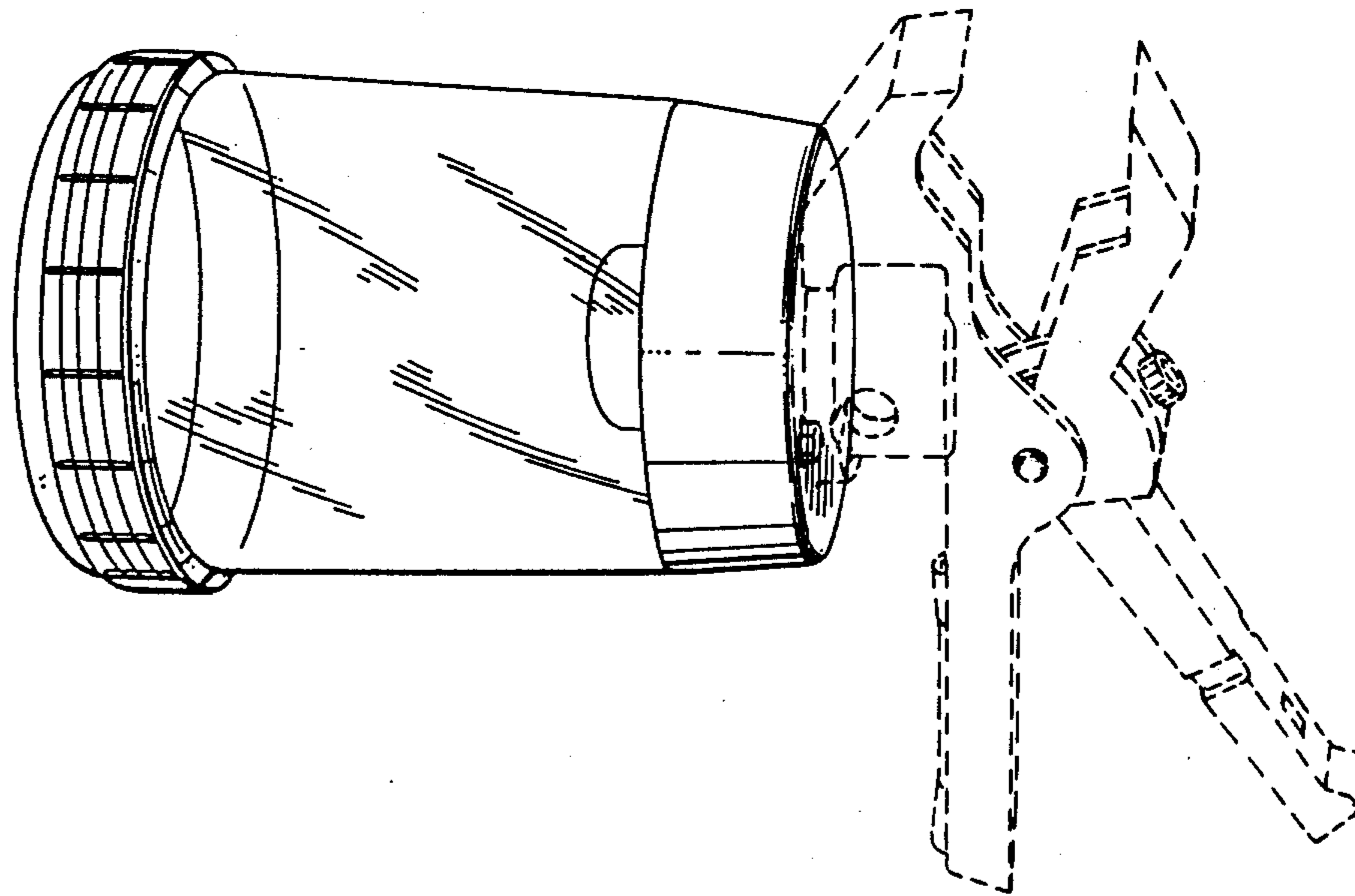

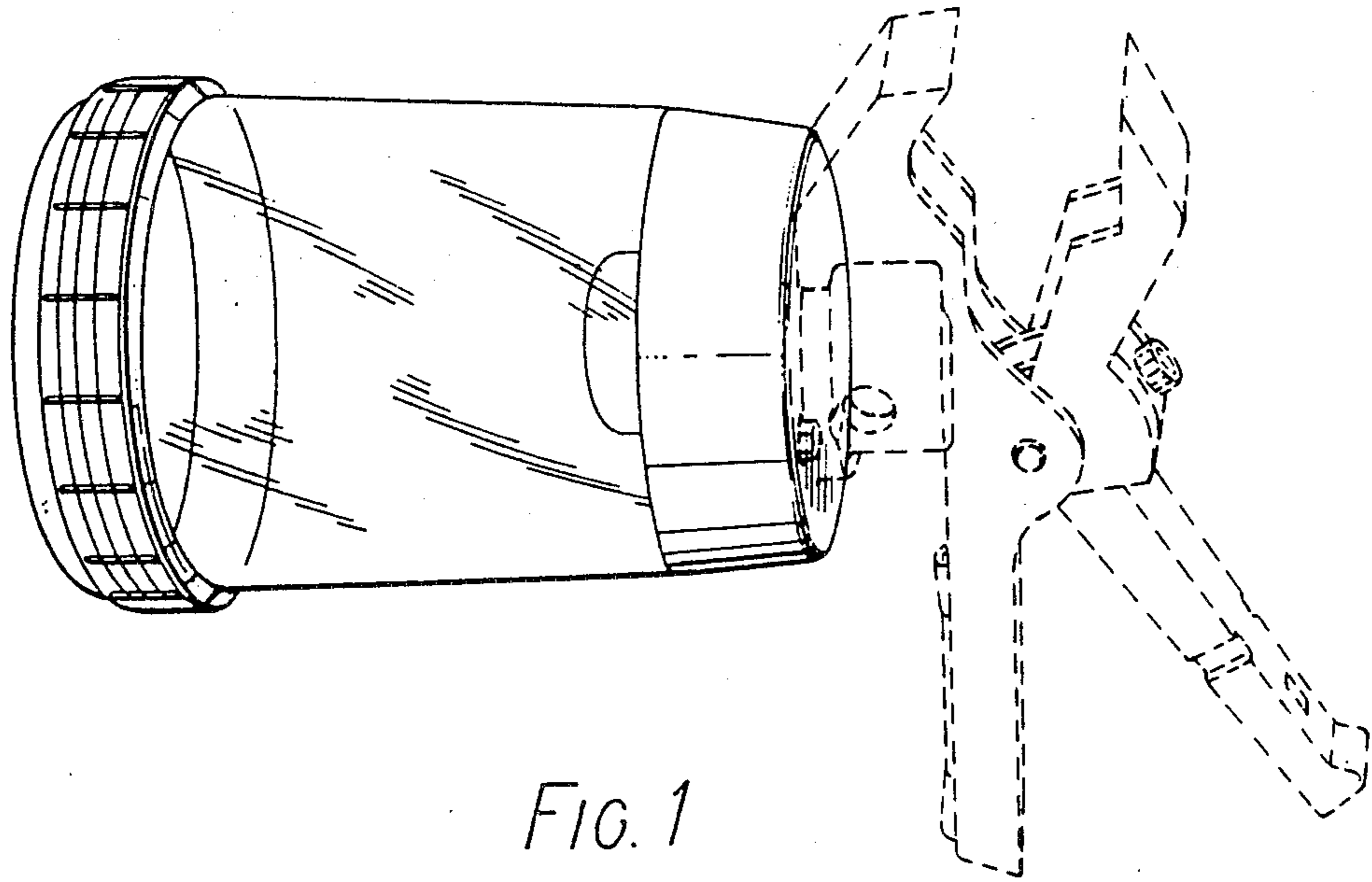

FIG. 1

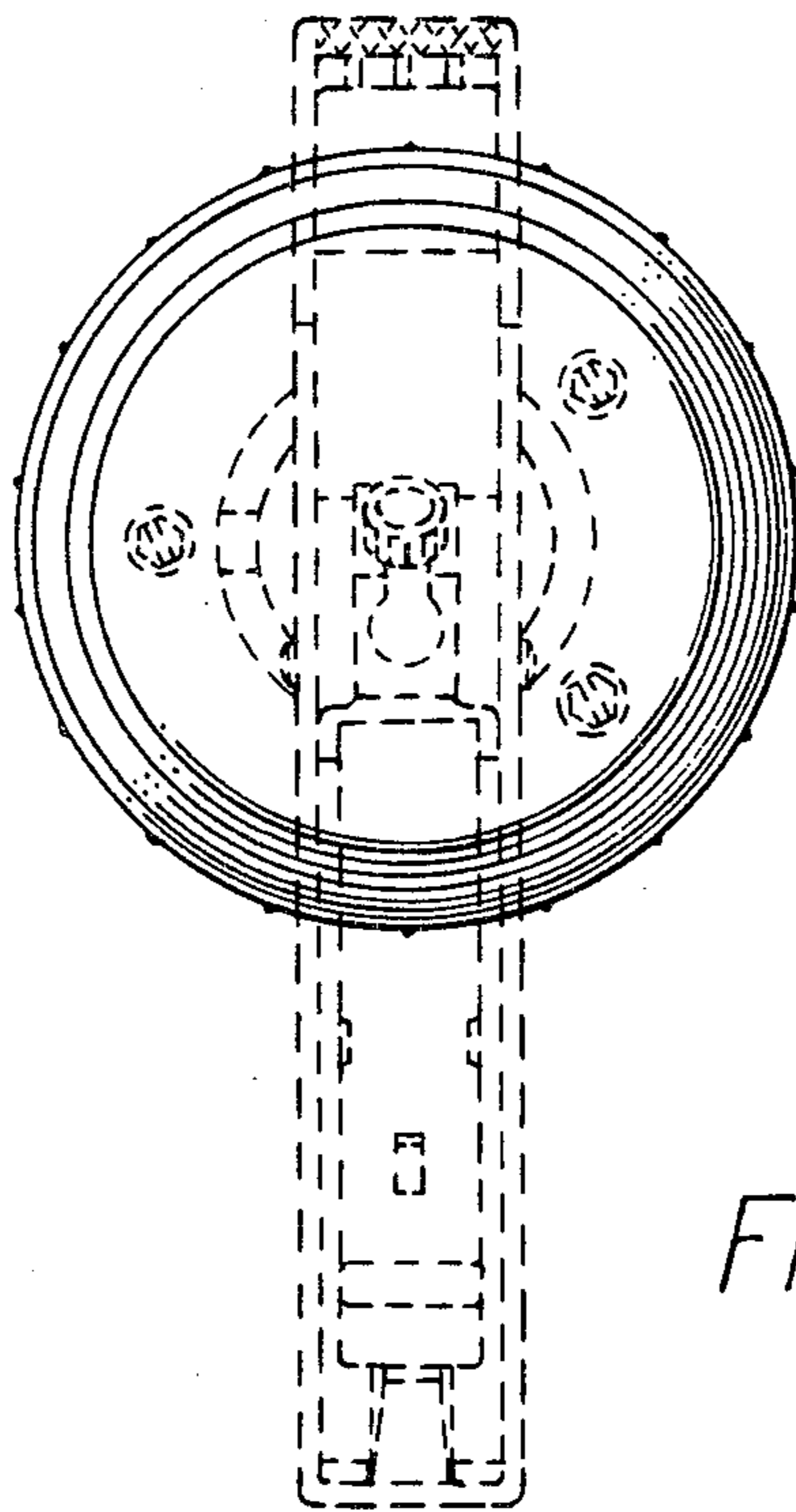

FIG. 4

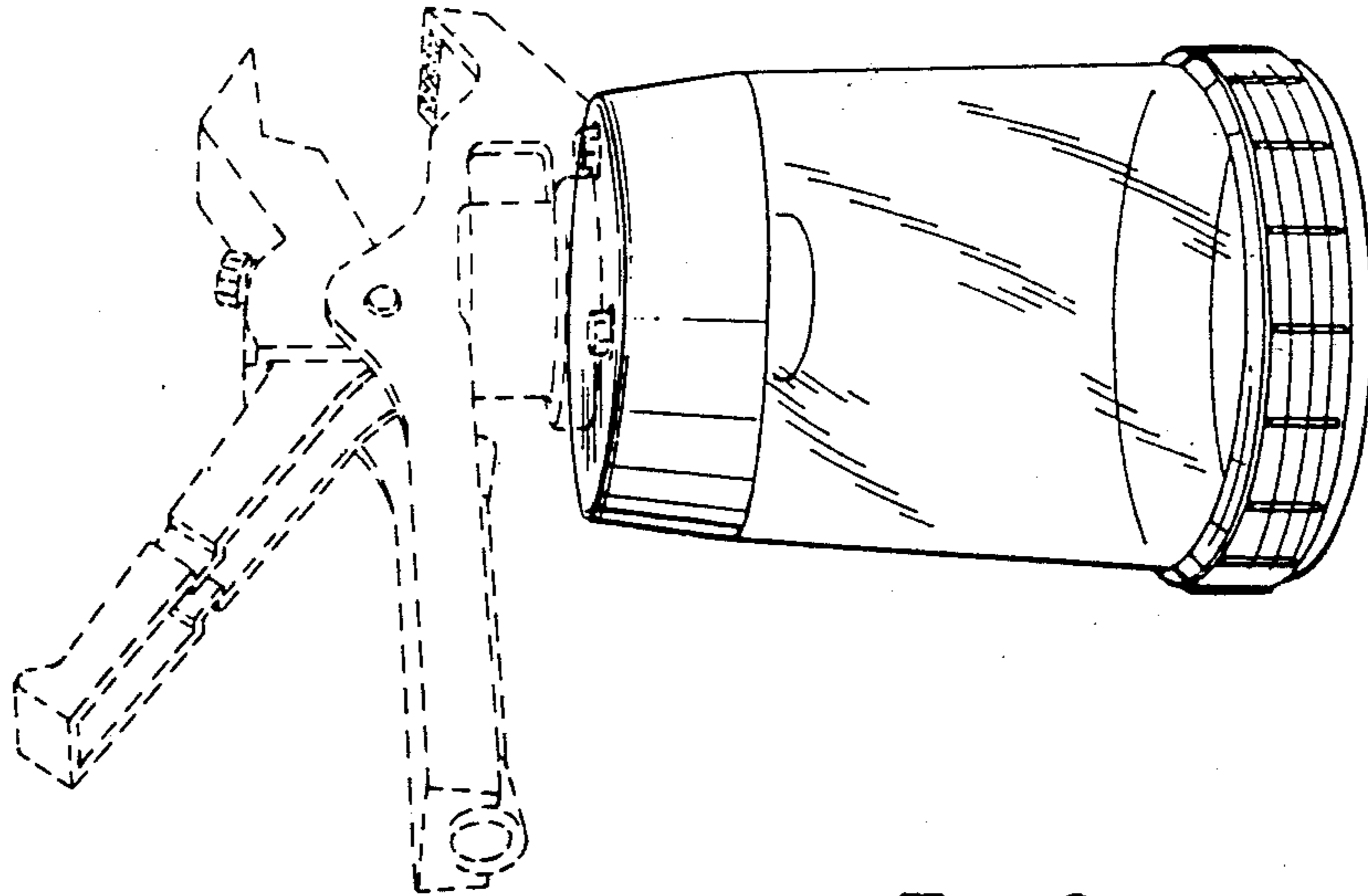

FIG. 2

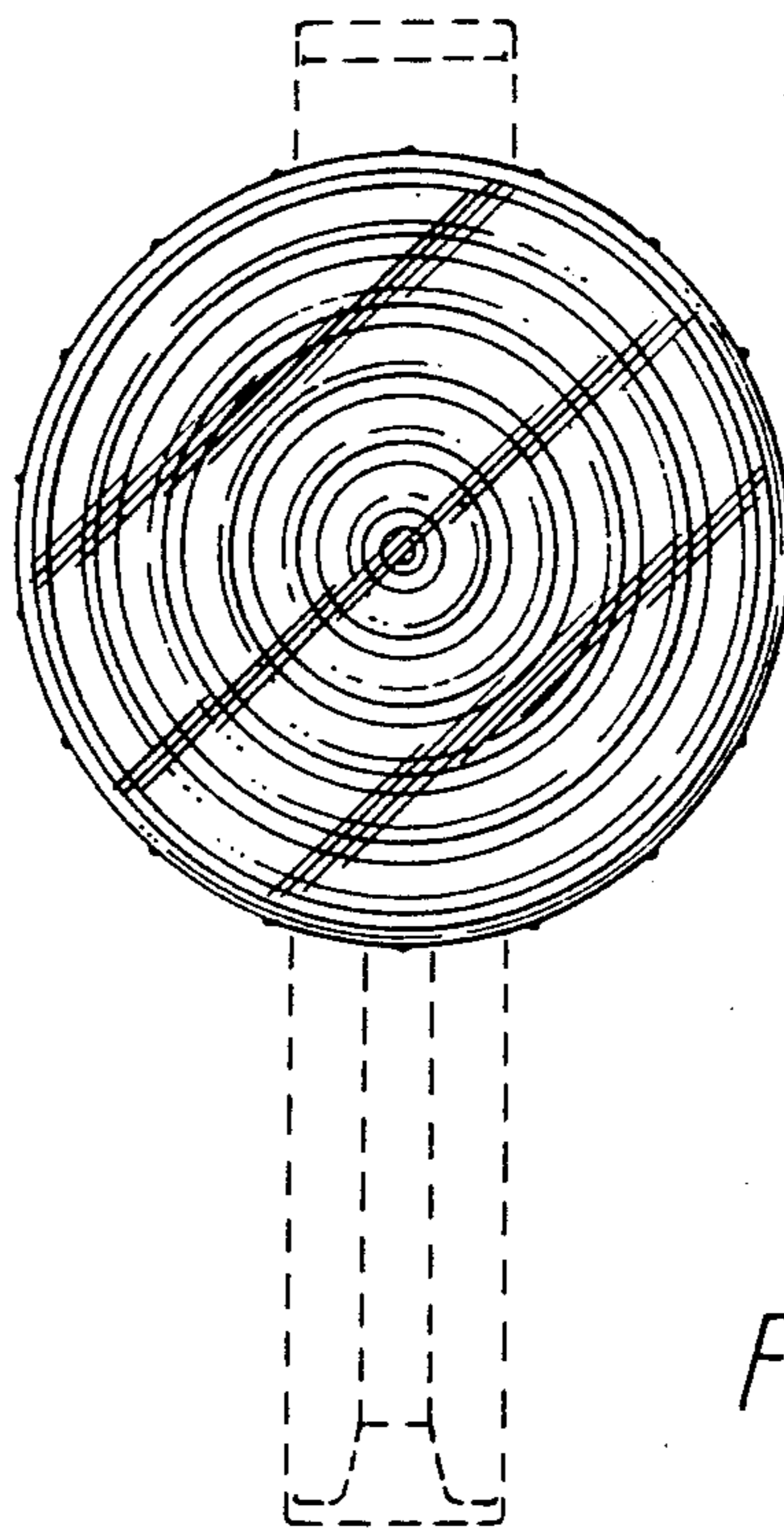

FIG. 3