

[54] SUSPENSION BLOCK

[76] Inventor: Pär-Ake Tu vesson, Lövängsvägen 4, Ängelholm, Sweden, S-262-00

[\*\*] Term: 14 Years

[21] Appl. No.: 659,224

[22] Filed: Oct. 9, 1984

[30] Foreign Application Priority Data

Apr. 9, 1984 [SE] Sweden ..... 1984-1150

[52] U.S. Cl. .... D8/373; D8/396

[58] Field of Search ..... D8/373, 394, 396; 248/49, 74.4, 311.2, 74.1, 67.5, 49, 205.1; D12/317

[56] References Cited

U.S. PATENT DOCUMENTS

D. 19,719	3/1890	Lee	.....	D8/396
D. 209,619	12/1967	Ray	.....	D8/396
D. 243,747	3/1977	Unghanse	.....	D8/396
D. 272,900	3/1984	Obst et al.	.....	D12/317
911,864	2/1909	Ball	.....	248/67.5
3,306,585	2/1967	Blum	.....	248/251
3,813,071	5/1974	Noryd	.....	248/251

3,908,074	9/1975	Berg	.....	248/205.1
4,029,276	6/1977	Zielie	.....	248/74.1
4,267,994	5/1981	Lynch et al.	.....	248/74.1
4,455,716	6/1984	Leonardo	.....	248/74.1

FOREIGN PATENT DOCUMENTS

1107975	3/1967	United Kingdom	.....	248/74.1
---------	--------	----------------	-------	----------

Primary Examiner—Wallace R. Burke  
Assistant Examiner—Horace B. Fay  
Attorney, Agent, or Firm—Bacon & Thomas

[57] CLAIM

The ornamental design for a suspension block, as shown and described.

DESCRIPTION

FIGS. 1 and 2 are, respectively, right and left side elevational views of a suspension block showing my new design;  
FIGS. 3 and 4 are, respectively, bottom and top plan views thereof;  
FIG. 5 is a front elevational view thereof;  
FIG. 6 is a front, top and right side perspective view thereof; and  
FIG. 7 is a rear, bottom and left side perspective view thereof.

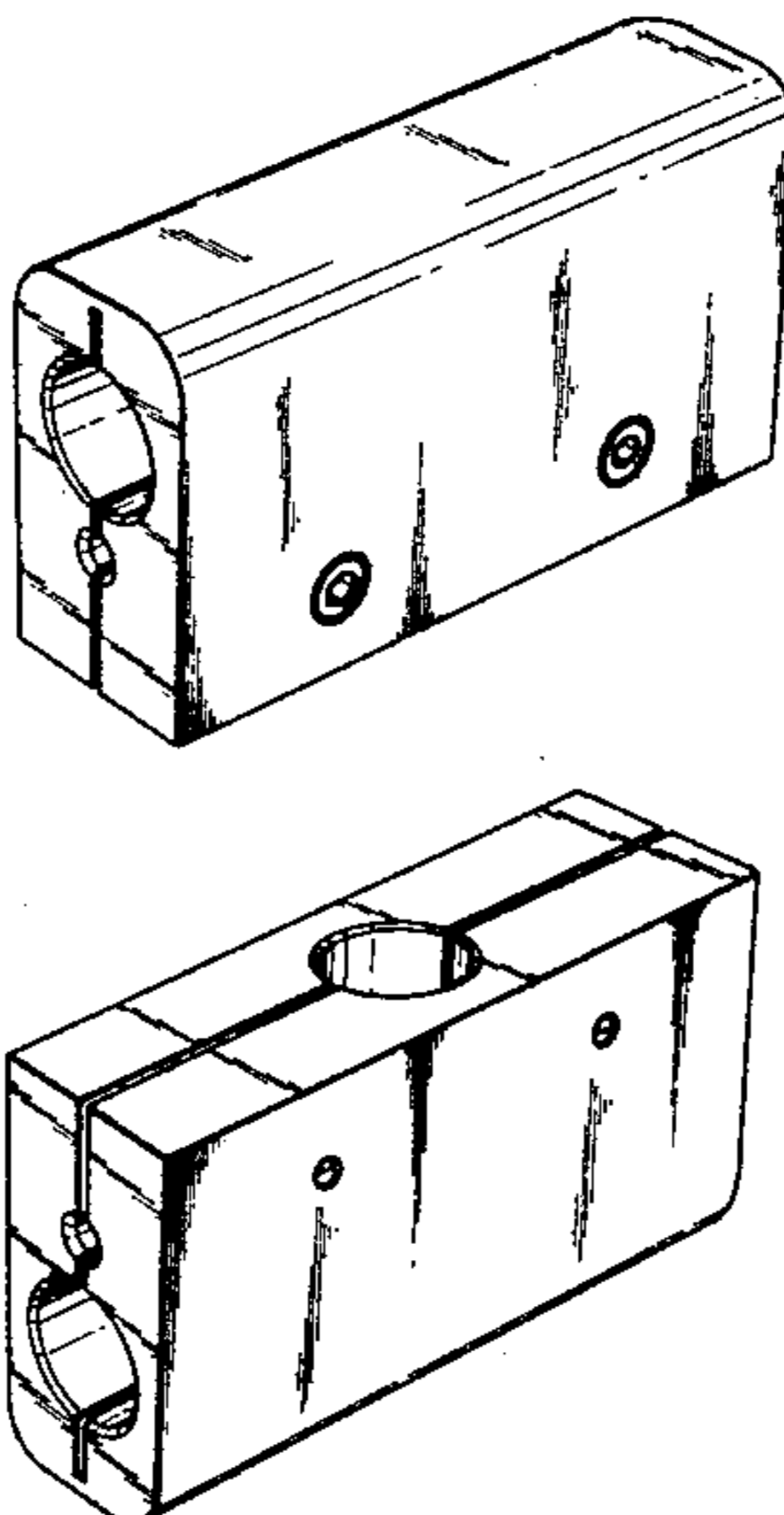

Fig. 1

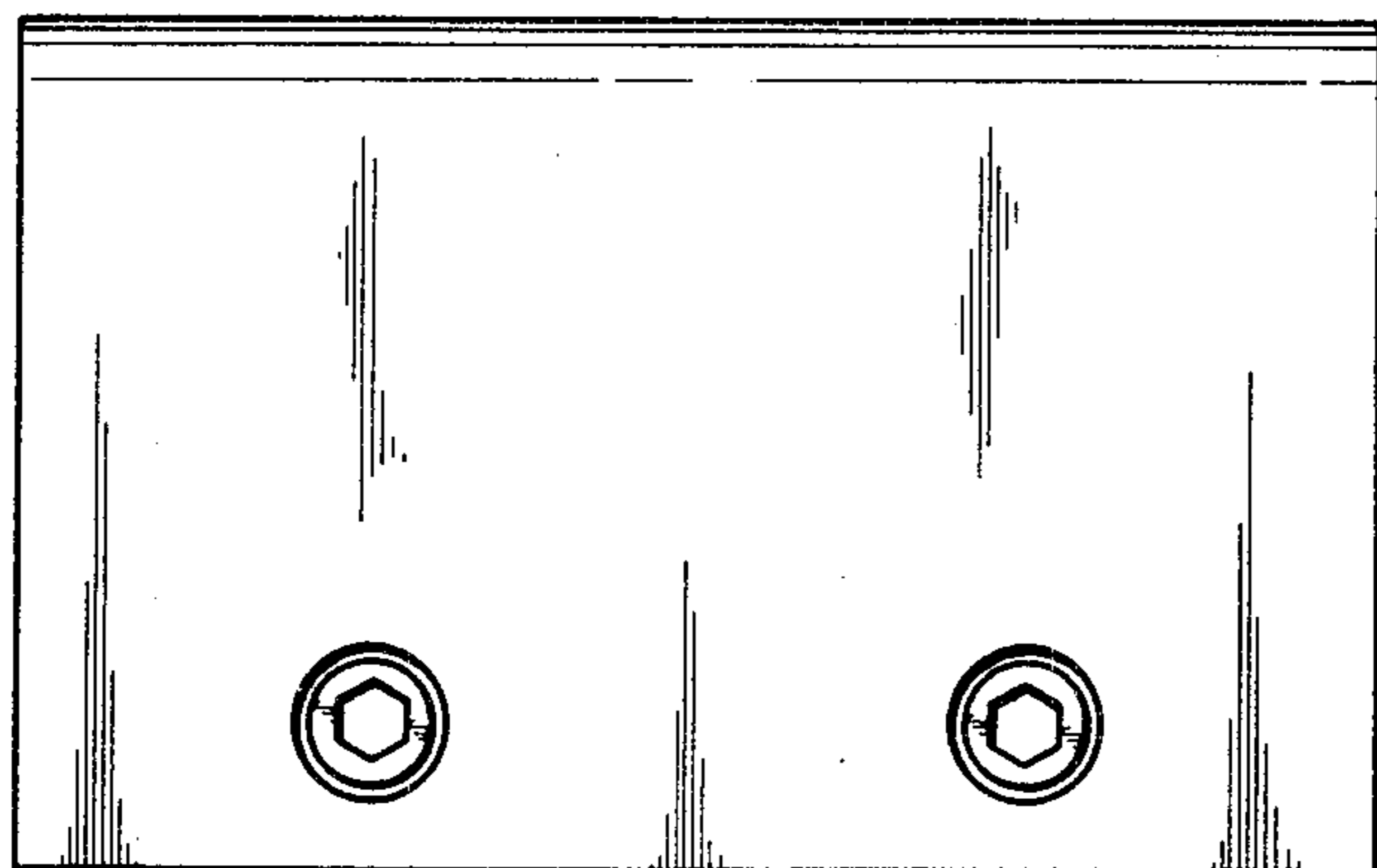

Fig. 5

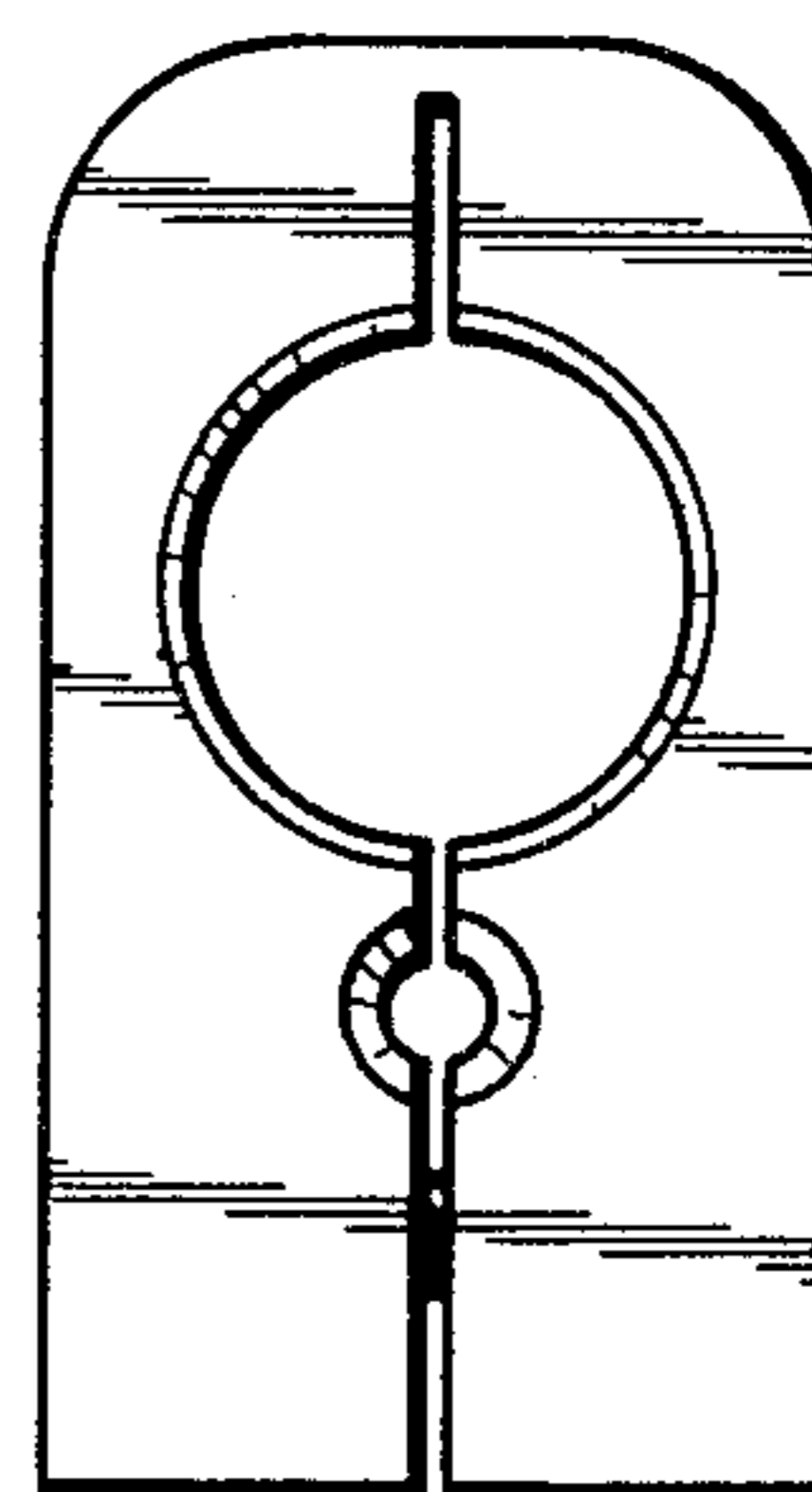

Fig. 2

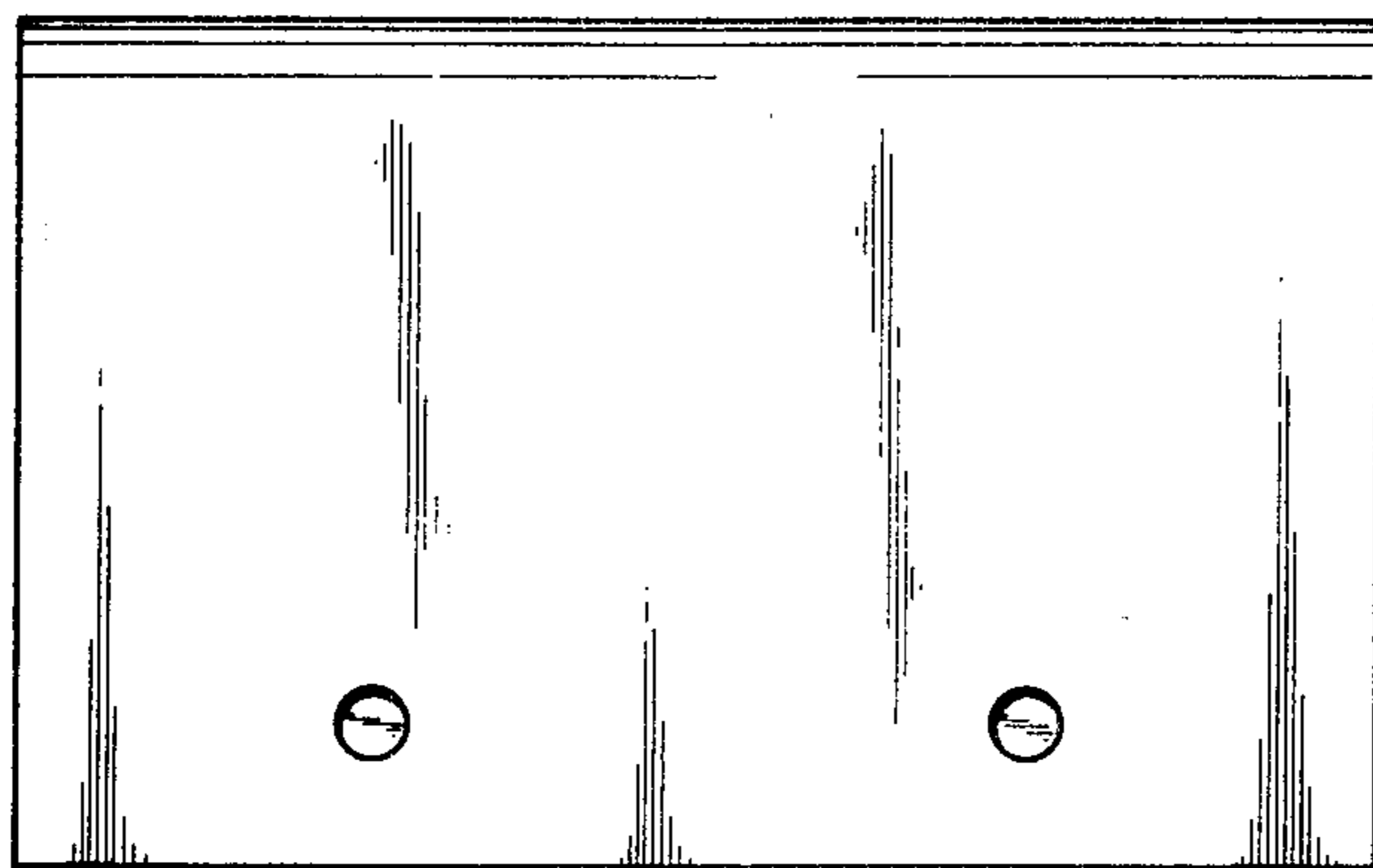

Fig. 3

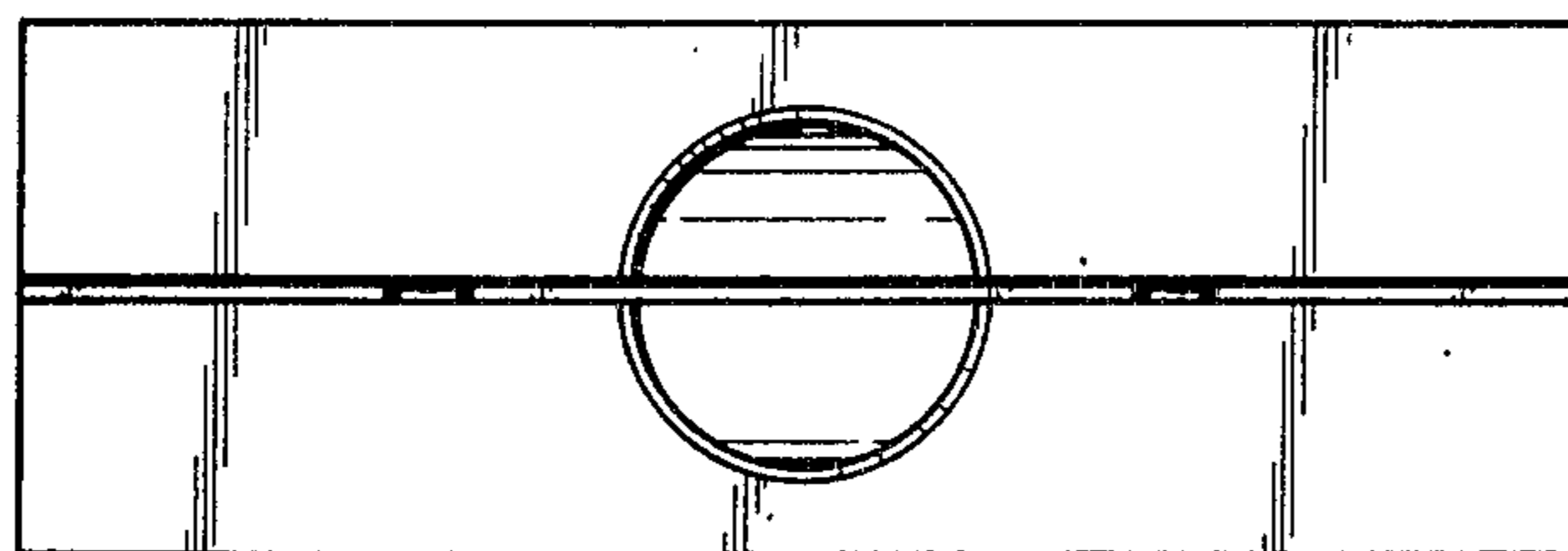

Fig. 4

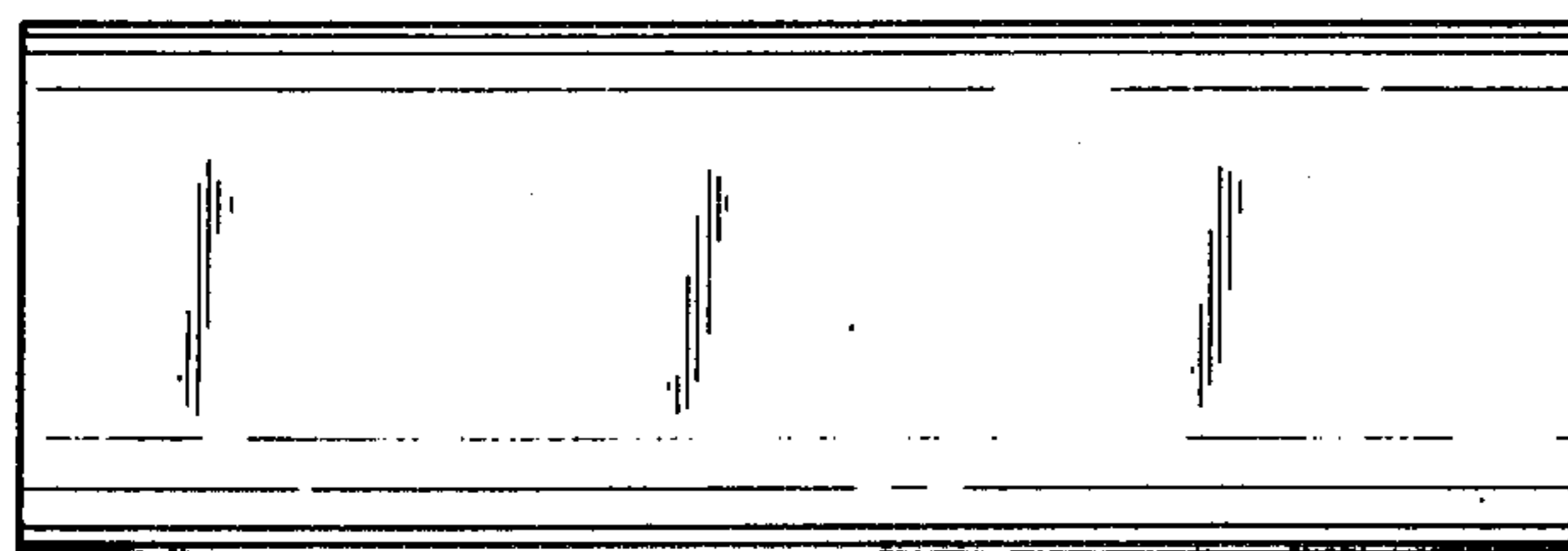

Fig. 6

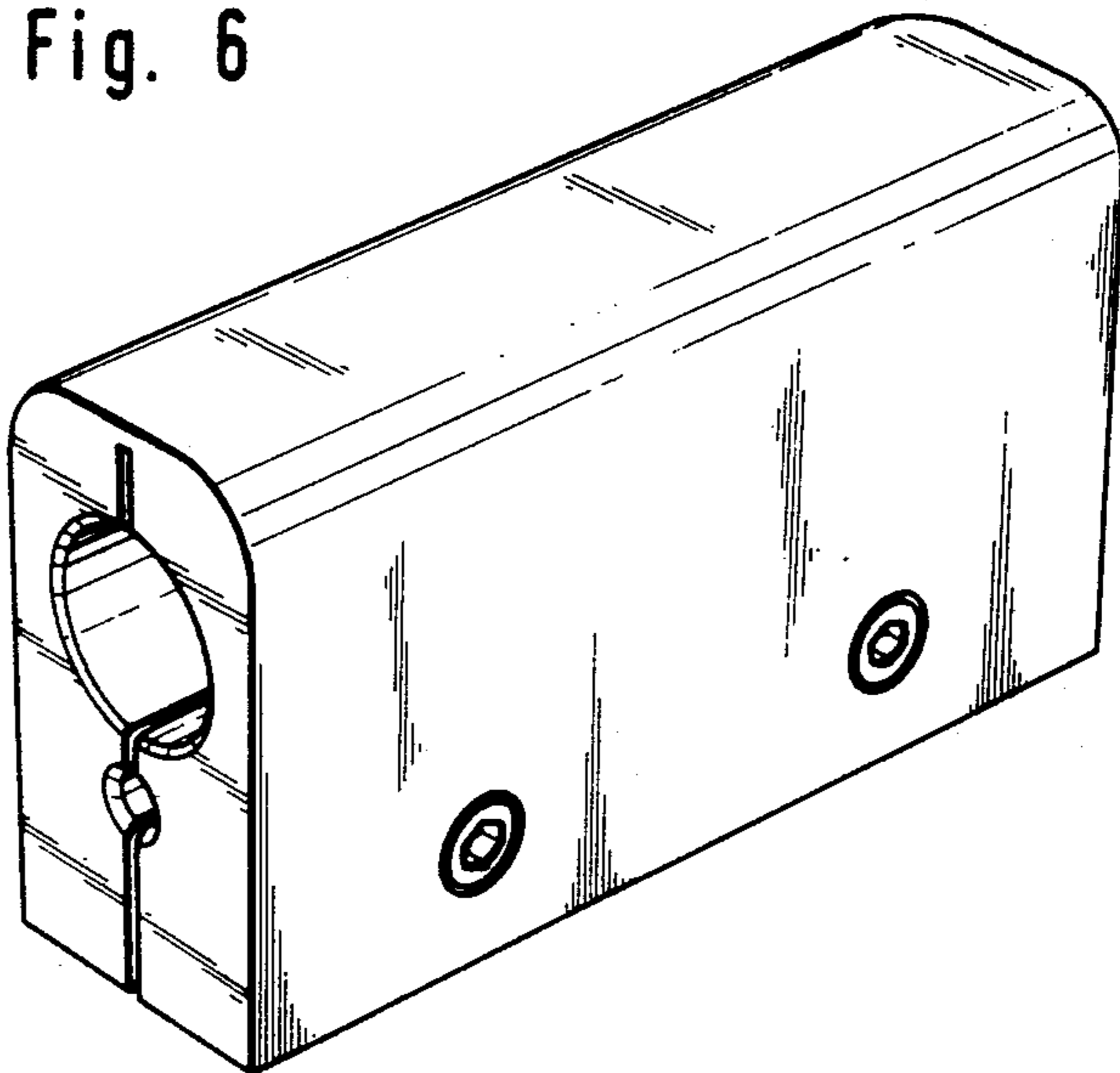

Fig. 7

