

[54] ACTUATOR FOR PUSH-PULL CABLES OR ELECTRIC SWITCHES FOR BICYCLES

[75] Inventor: Christopher J. Boyett, Nottingham, England

[73] Assignee: TI Sturmey-Archer Limited, Nottingham, England

[**] Term: 14 Years

[21] Appl. No.: 597,122

[22] Filed: Apr. 5, 1984

[30] Foreign Application Priority Data

Jan. 25, 1984 [GB] United Kingdom 1017527

[52] U.S. Cl. D12/179

[58] Field of Search D13/32-34, D13/99; 200/293-294, 297, 302.1, 302.2, 329, 333-334, 340; D12/179; 74/488-489, 491-492, 498, 505, 551.8

[56] References Cited

U.S. PATENT DOCUMENTS

D. 112,128	11/1938	Peo	D12/179
D. 208,128	7/1967	Brilando et al.	D12/179
D. 213,605	3/1969	Shimano et al.	D12/179
D. 215,044	8/1969	Ozaki	D12/179
D. 265,817	8/1982	Hahn	D12/179
4,137,793	2/1979	Sowell	74/488

OTHER PUBLICATIONS

WheelGoods Corporation, "The Handbook of Cyclology" Sixth Edition, ©1967-1973, p. 47, Record Front Changer, item 1052/1.

WheelGoods Corporation, "The Handbook of Cyclology" Sixth Edition, ©1967-1973, p. 57, right hand lever ref. 2950.

WheelGoods Corporation, "The Handbook of Cyclology" Sixth Edition, ©1967-1973, p. 52, Huret "Luxe" No. 700.

Primary Examiner—Wallace R. Burke

Assistant Examiner—Ruth E. Takemoto

[57] CLAIM

The ornamental design for an actuator for push-pull cables or electric switches for bicycles, as shown.

DESCRIPTION

FIG. 1 is an end elevational view of an actuator for a push-pull cable or electric switch for bicycles showing my new design;

FIG. 2 is a side elevational view thereof;

FIG. 3 is a side elevational view thereof, from the opposite side of FIG. 2;

FIG. 4 is a perspective view showing the top and a side and end thereof;

FIG. 5 is an end elevational view thereof, from the end opposed to FIG. 1;

FIG. 6 is a top plan view thereof; and

FIG. 7 is a bottom plan view thereof.

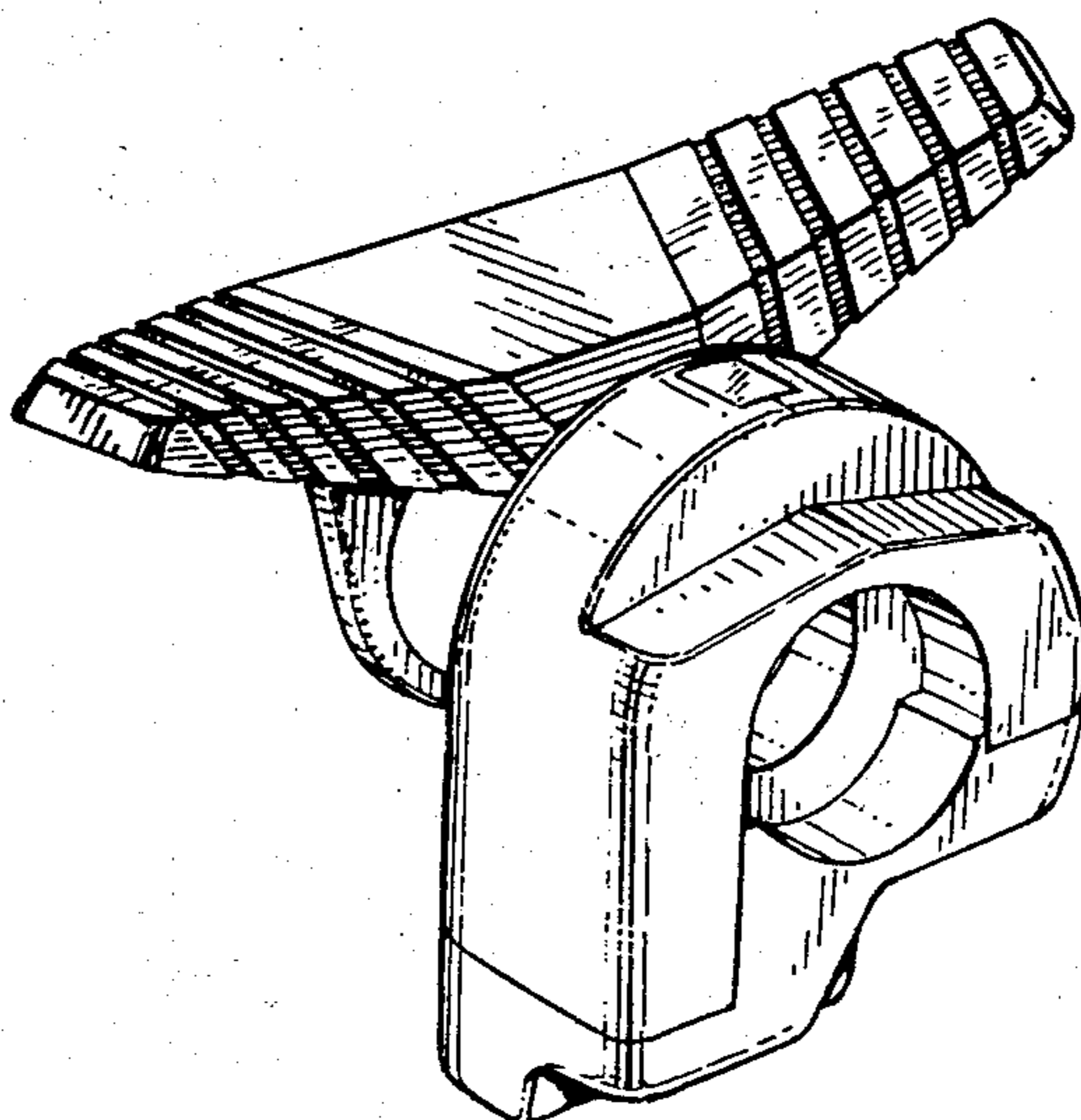

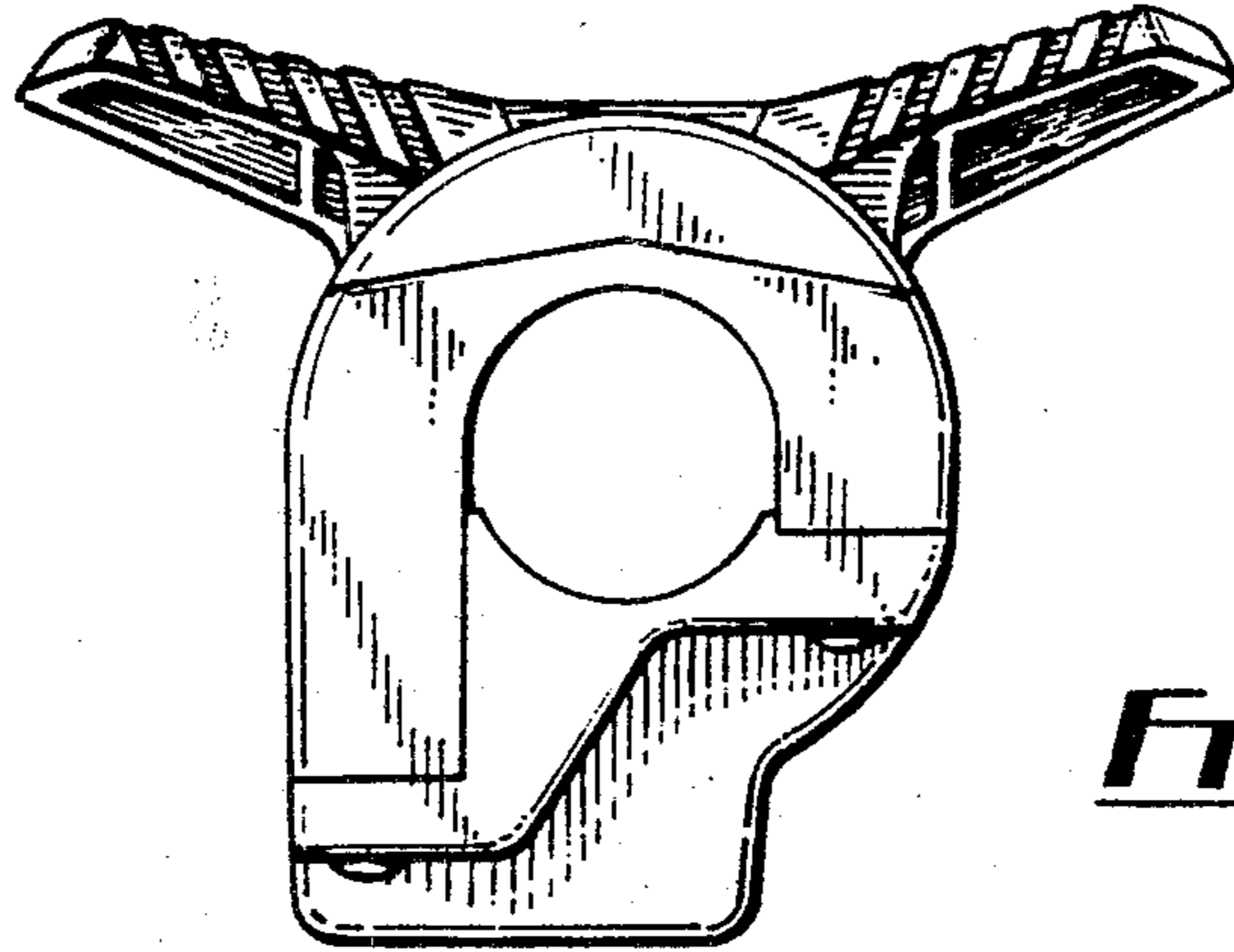

FIG. 1

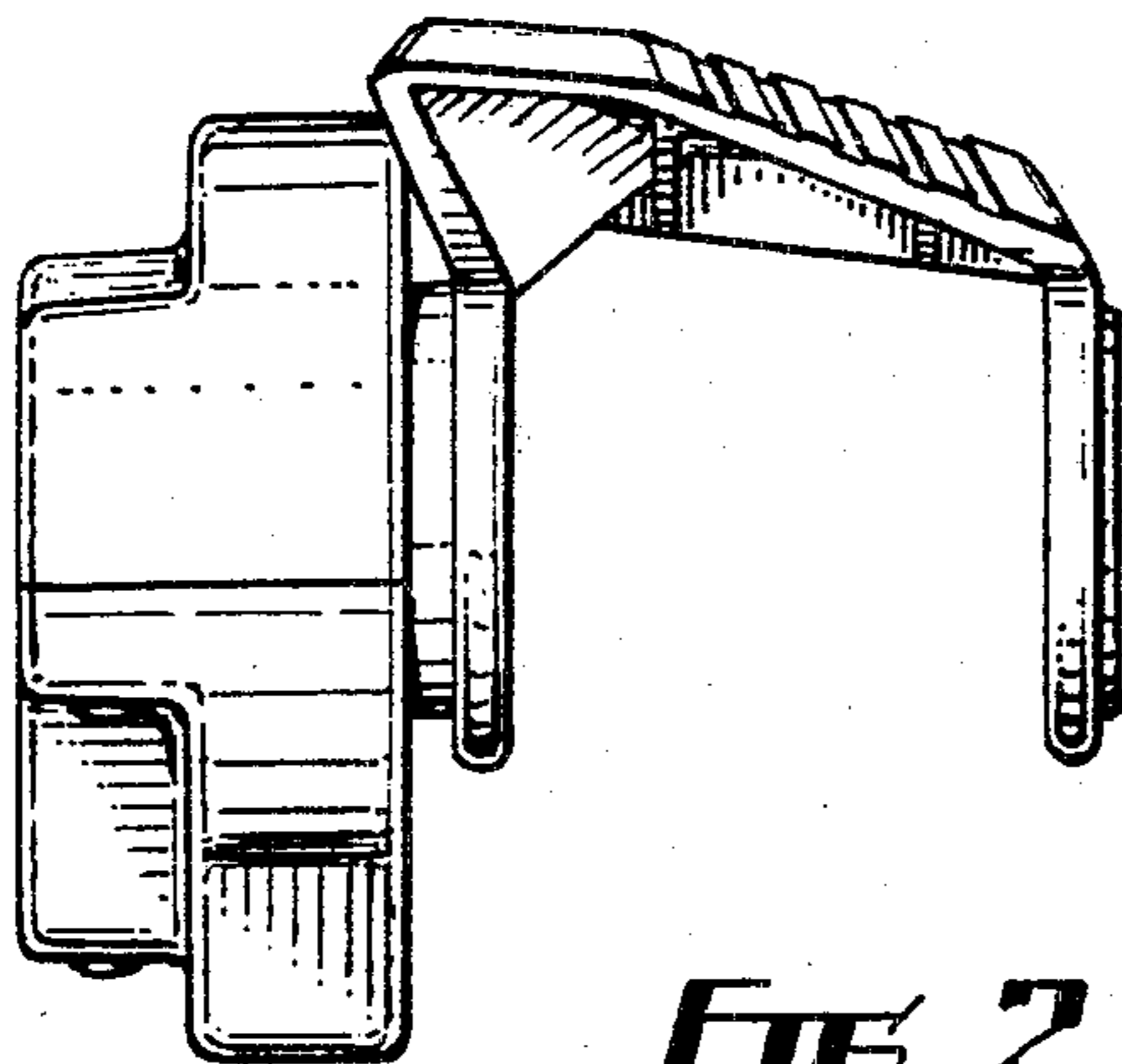

FIG. 2

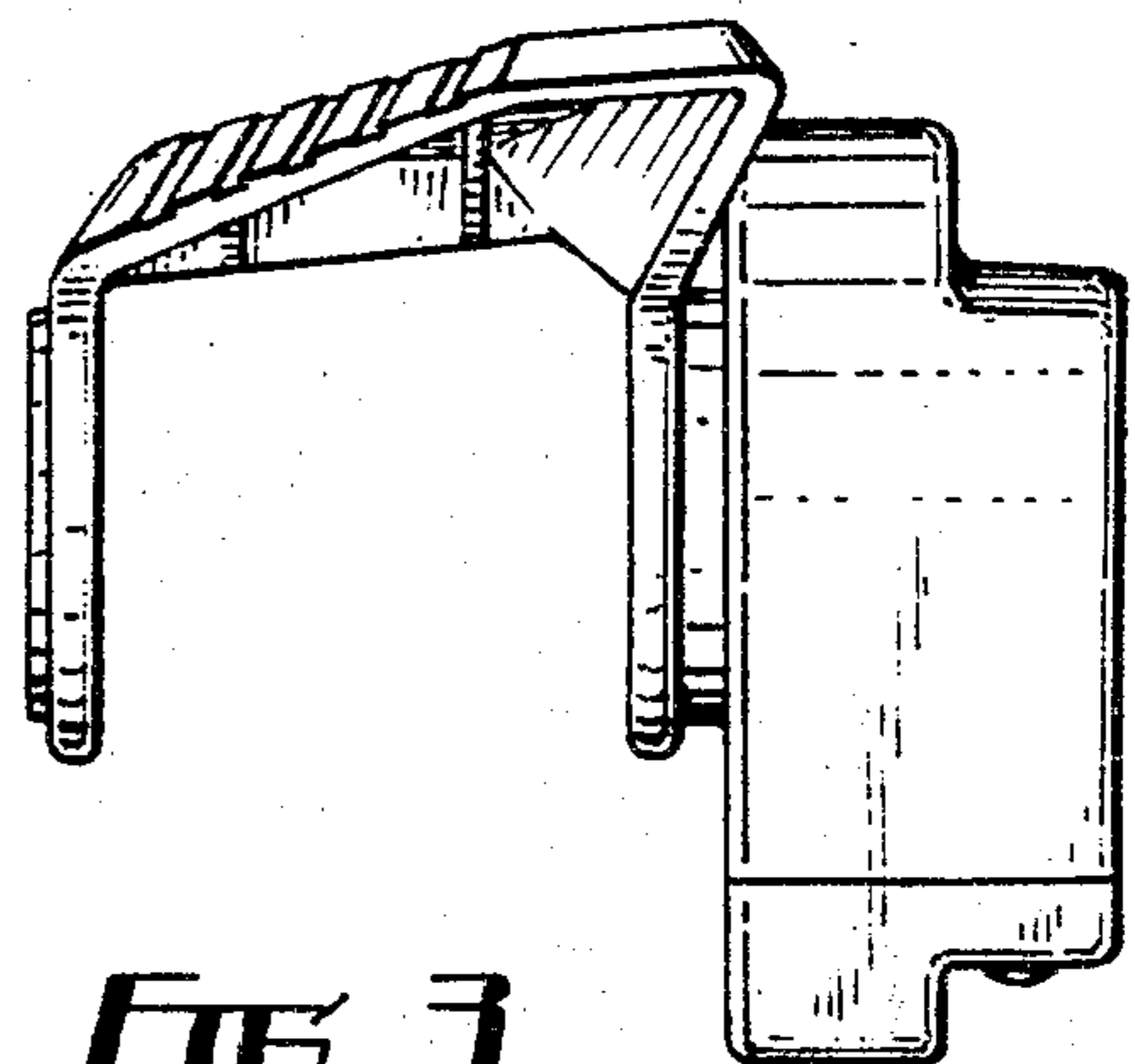

FIG. 3

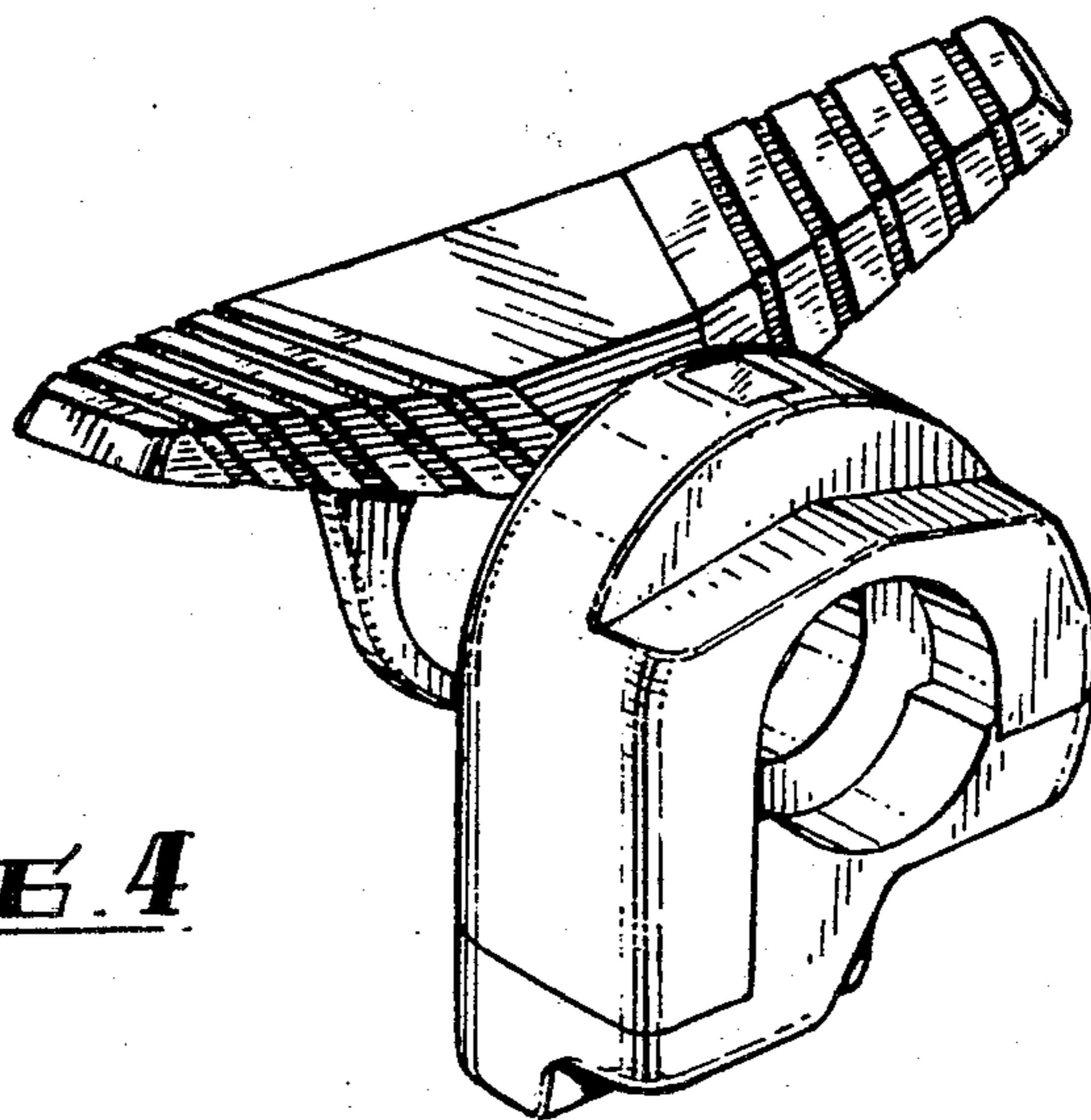

FIG. 4

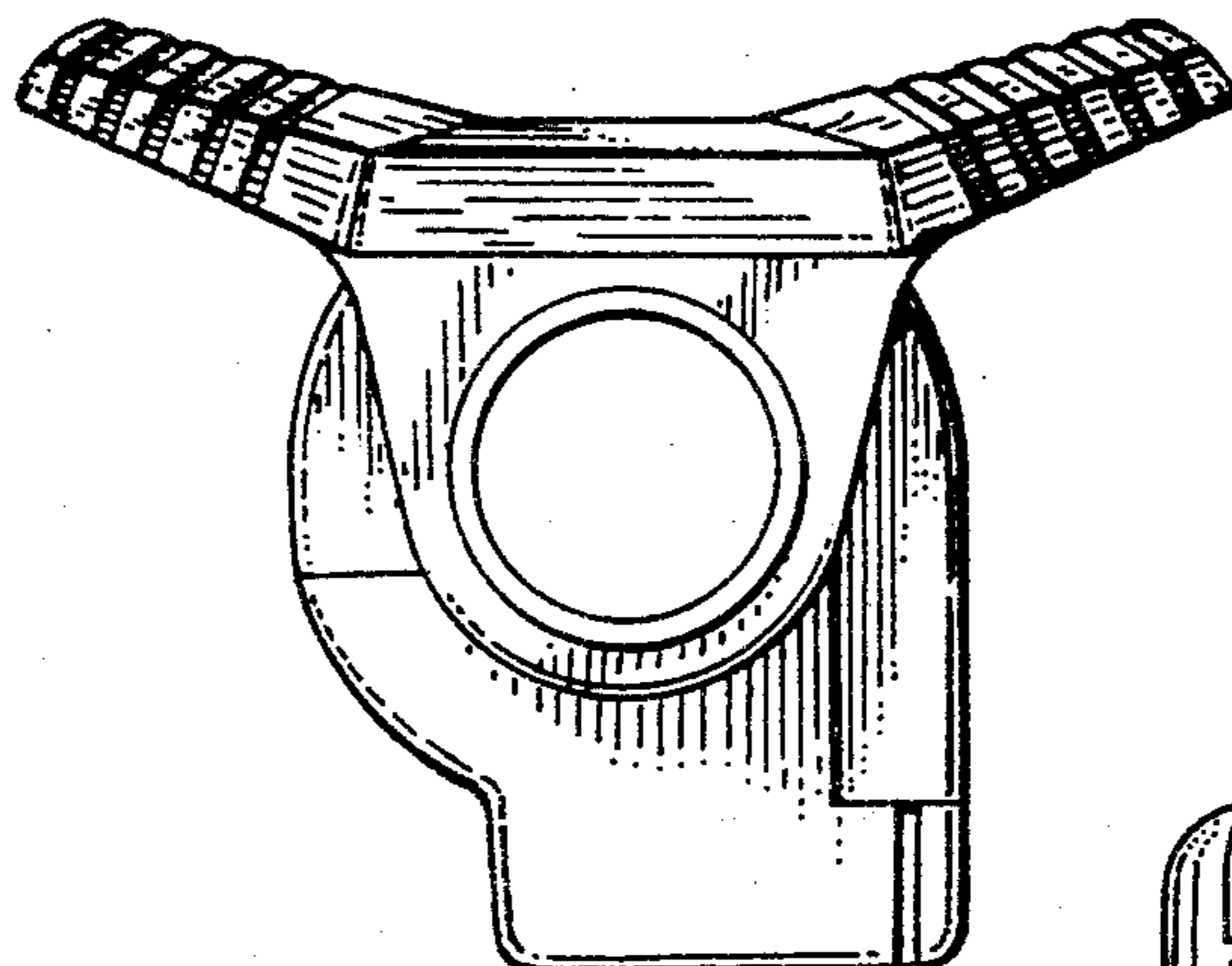

FIG. 5

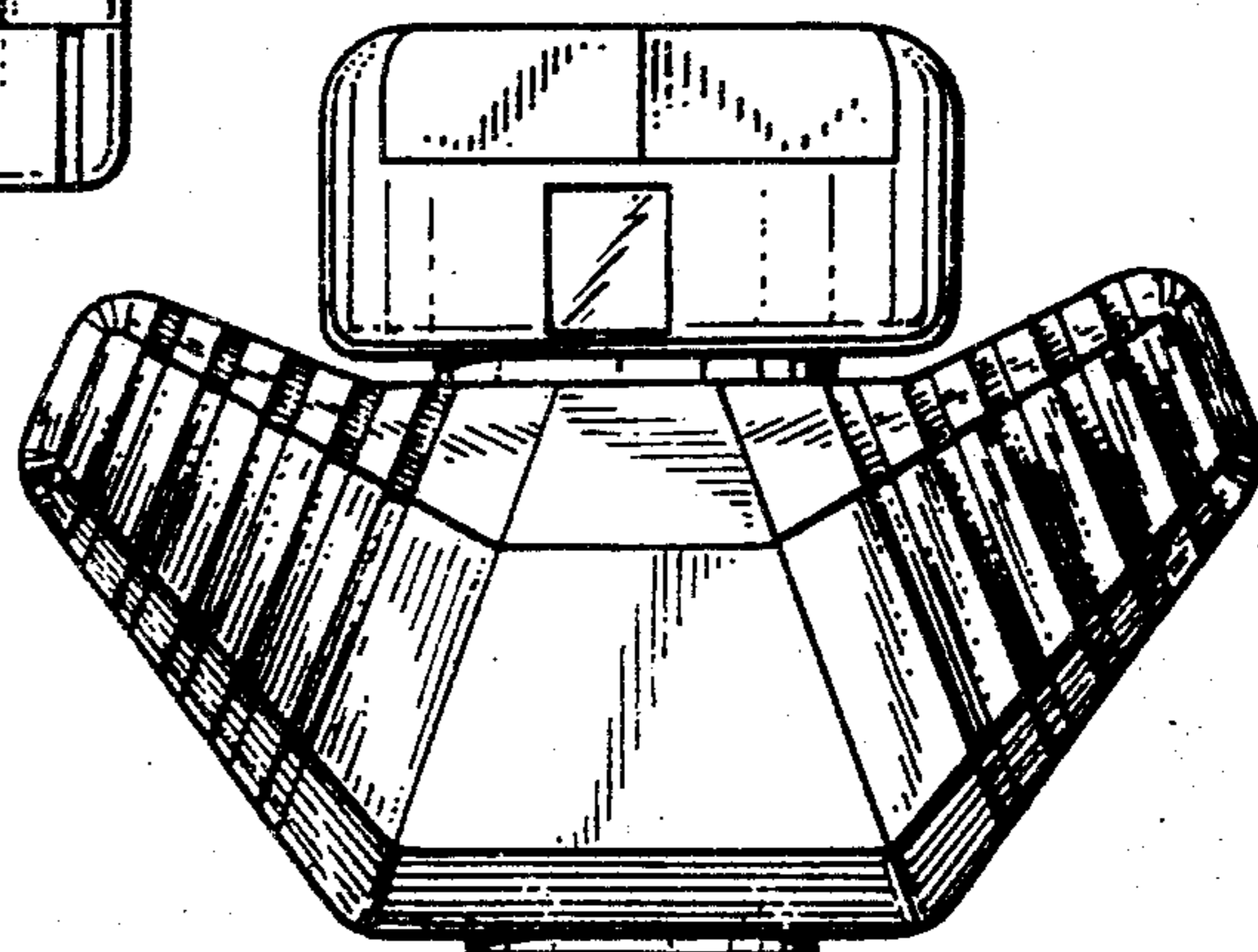

FIG. 6

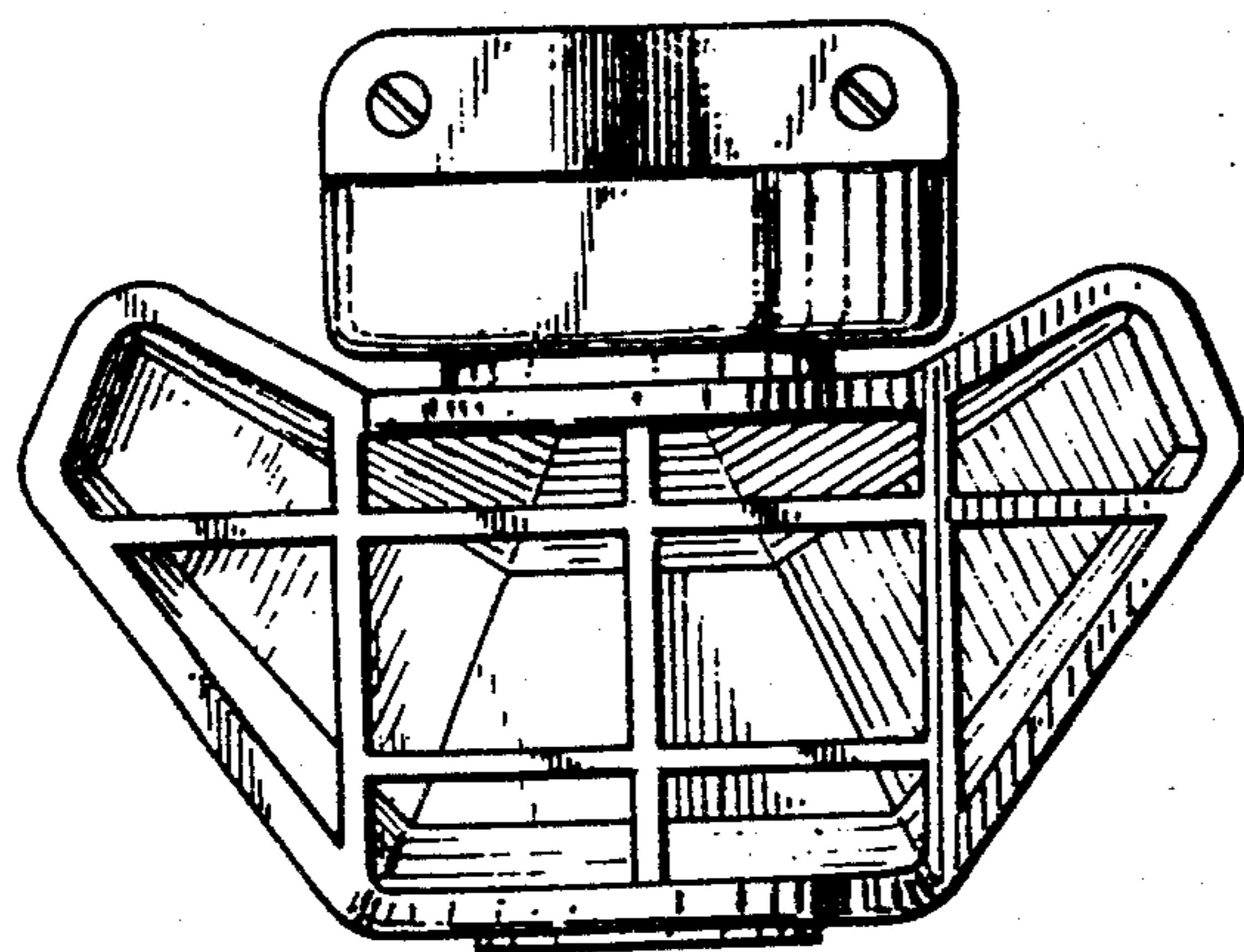

FIG. 7