

[54] PRECISION MEASURING DEVICE

[56] References Cited

[75] Inventors: Phillip J. Kronzer, Los Gatos; Nick Caputo, San Jose; Bernard M. Combs, Los Altos; Andrew Conrad, Campbell; James Kalani; Timothy L. Kronzer, both of Los Gatos, all of Calif.

U.S. PATENT DOCUMENTS

| | | | | |
|------------|--------|-----------|-------|----------|
| D. 192,384 | 3/1962 | Wiegel | | D10/71 X |
| D. 201,768 | 7/1965 | Conover | | D10/62 |
| 2,537,704 | 1/1951 | Reinhart | | 33/169 R |
| 3,251,133 | 5/1966 | Turtschan | | 33/169 R |
| 3,319,339 | 5/1967 | Marconi | | 33/169 R |
| 4,599,801 | 7/1986 | Kronzer | | 33/169 R |

[73] Assignee: K & K Manufacturing, Inc., Campbell, Calif.

Primary Examiner—Nelson C. Holtje
Attorney, Agent, or Firm—Claude A. S. Hamrick

[**] Term: 14 Years

[57] CLAIM

The ornamental design for a precision measuring device, substantially as shown and described.

[21] Appl. No.: 663,763

DESCRIPTION

[22] Filed: Oct. 22, 1984

[52] U.S. Cl. D10/73; D10/70

[58] Field of Search D10/70, 73; 33/548, 33/560, 169 R, 170

FIG. 1 is a right front perspective view of a precision measuring device showing my new design; FIG. 2 is a front elevational view thereof; FIG. 3 is a right side elevational view thereof; FIG. 4 is a top plan view thereof; FIG. 5 is a rear elevational view thereof; and FIG. 6 is a bottom plan view thereof.

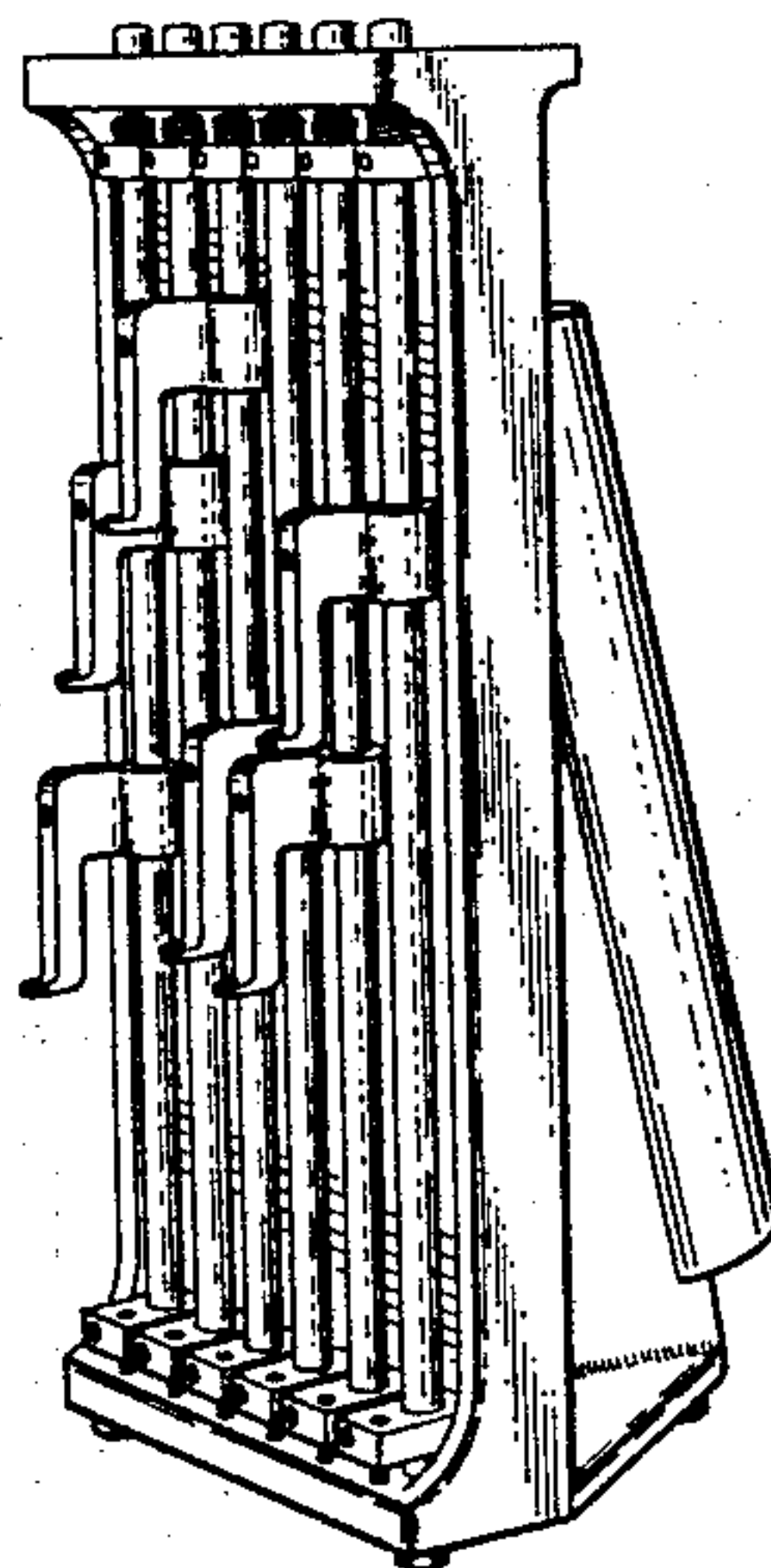

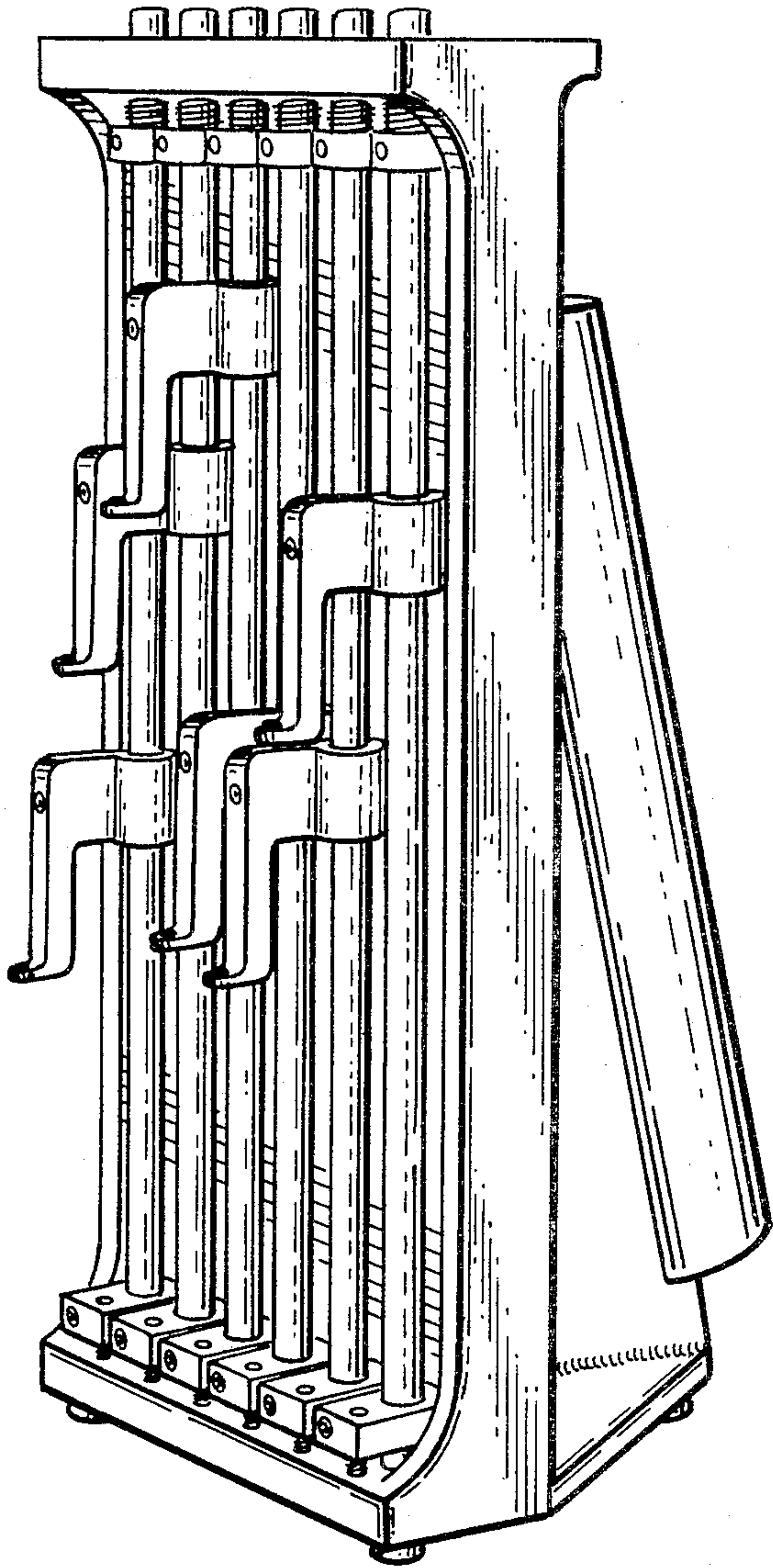

Fig. 1

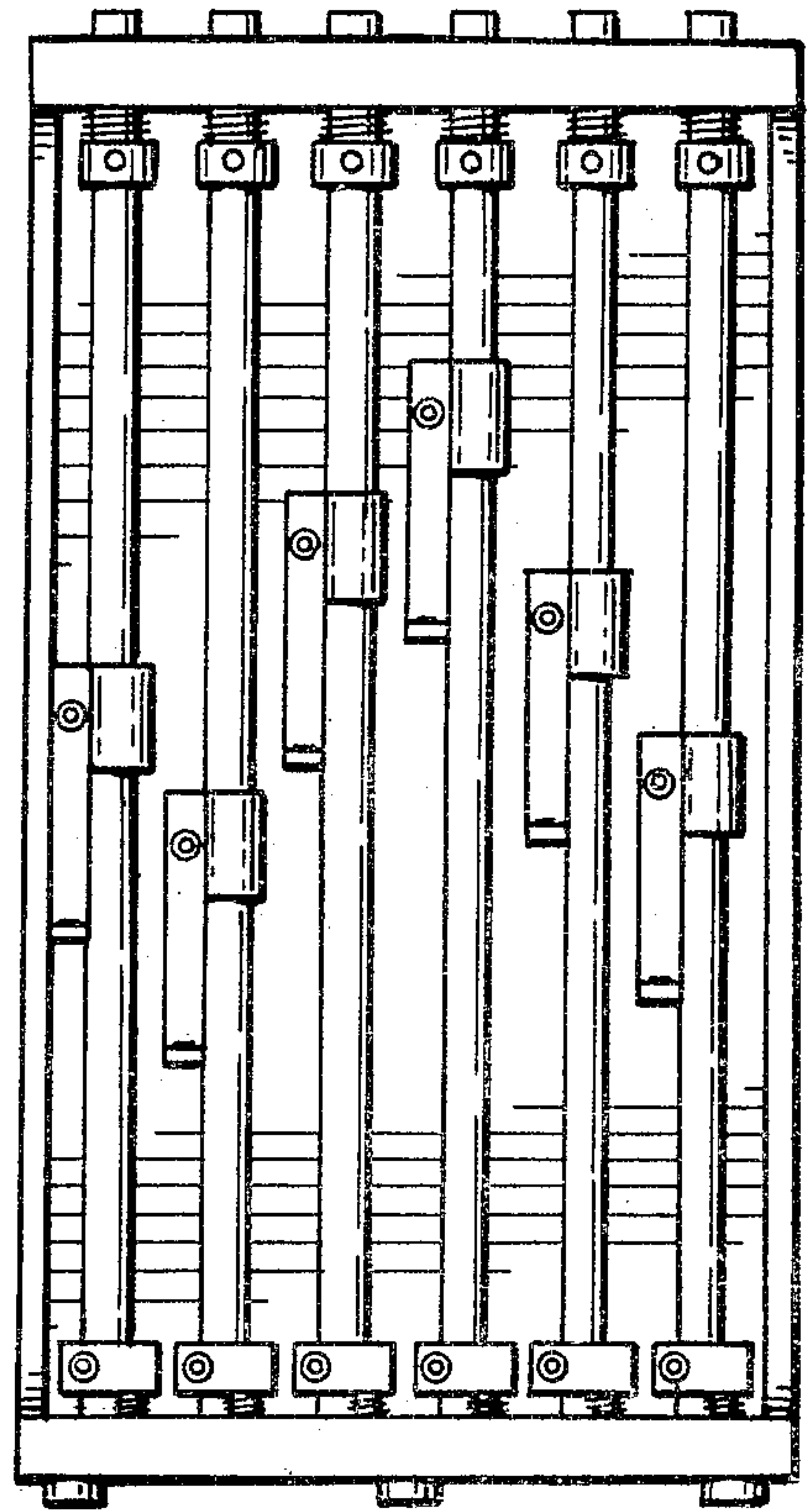

Fig. 2

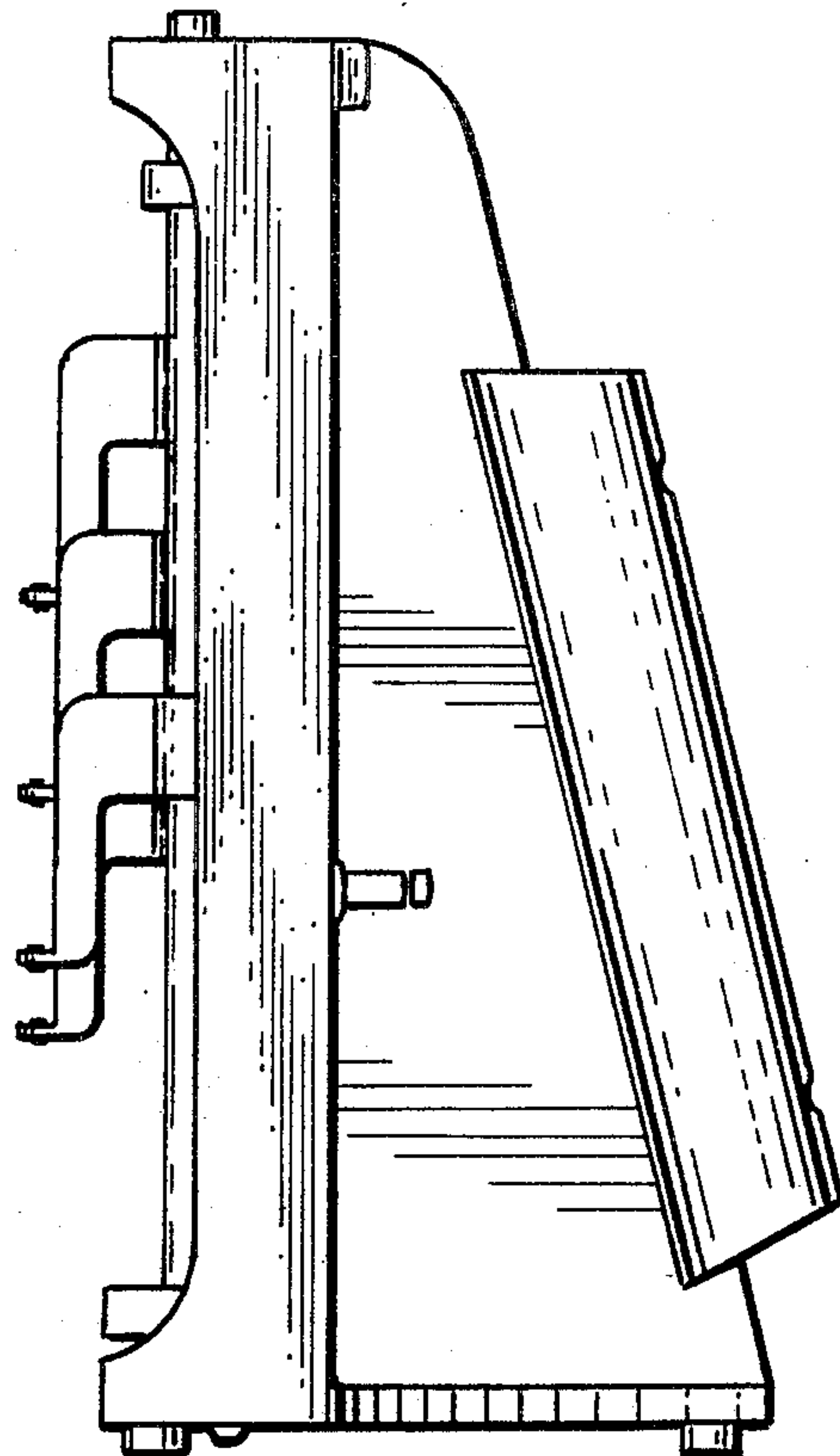

Fig. 3

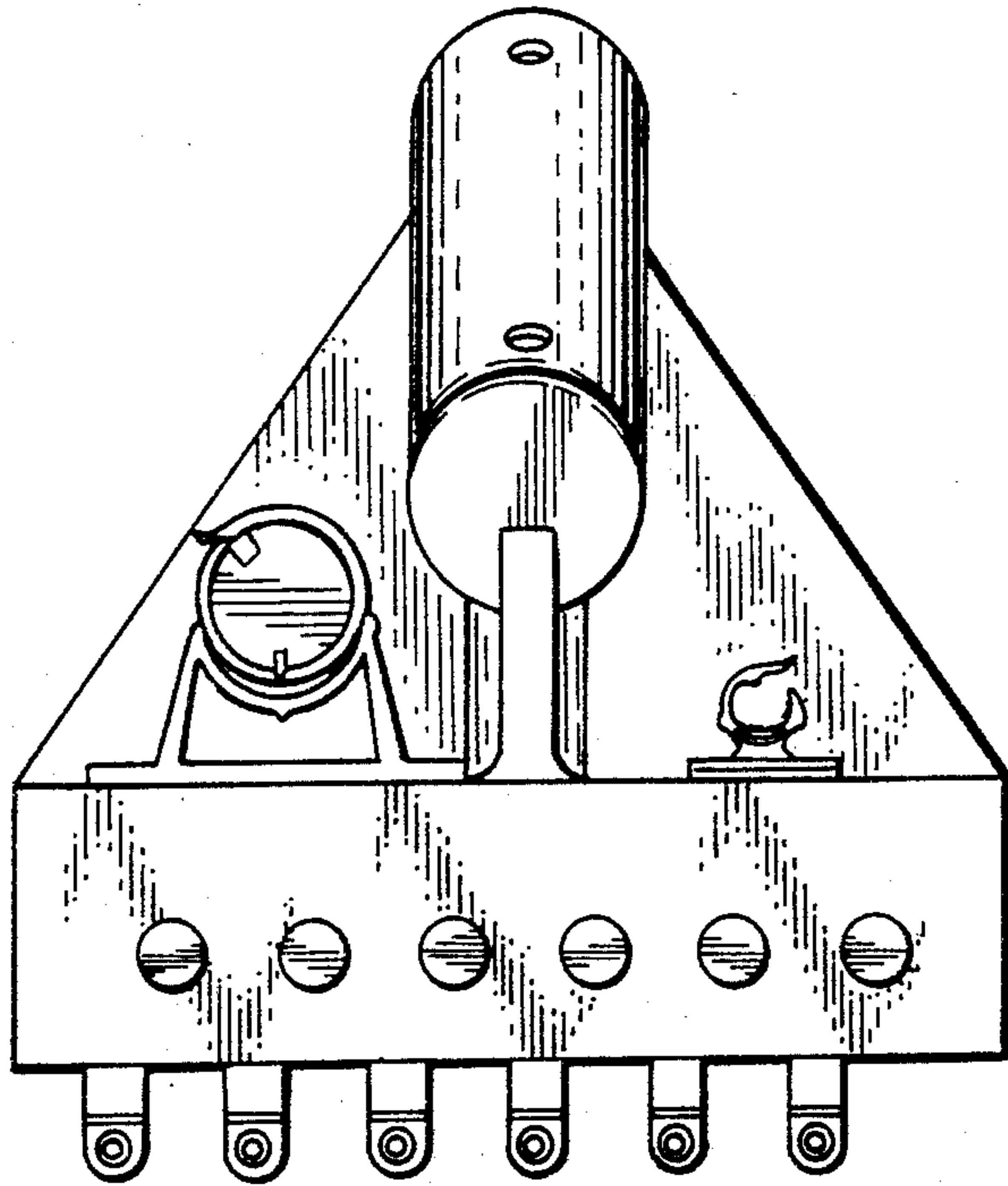

Fig. 4

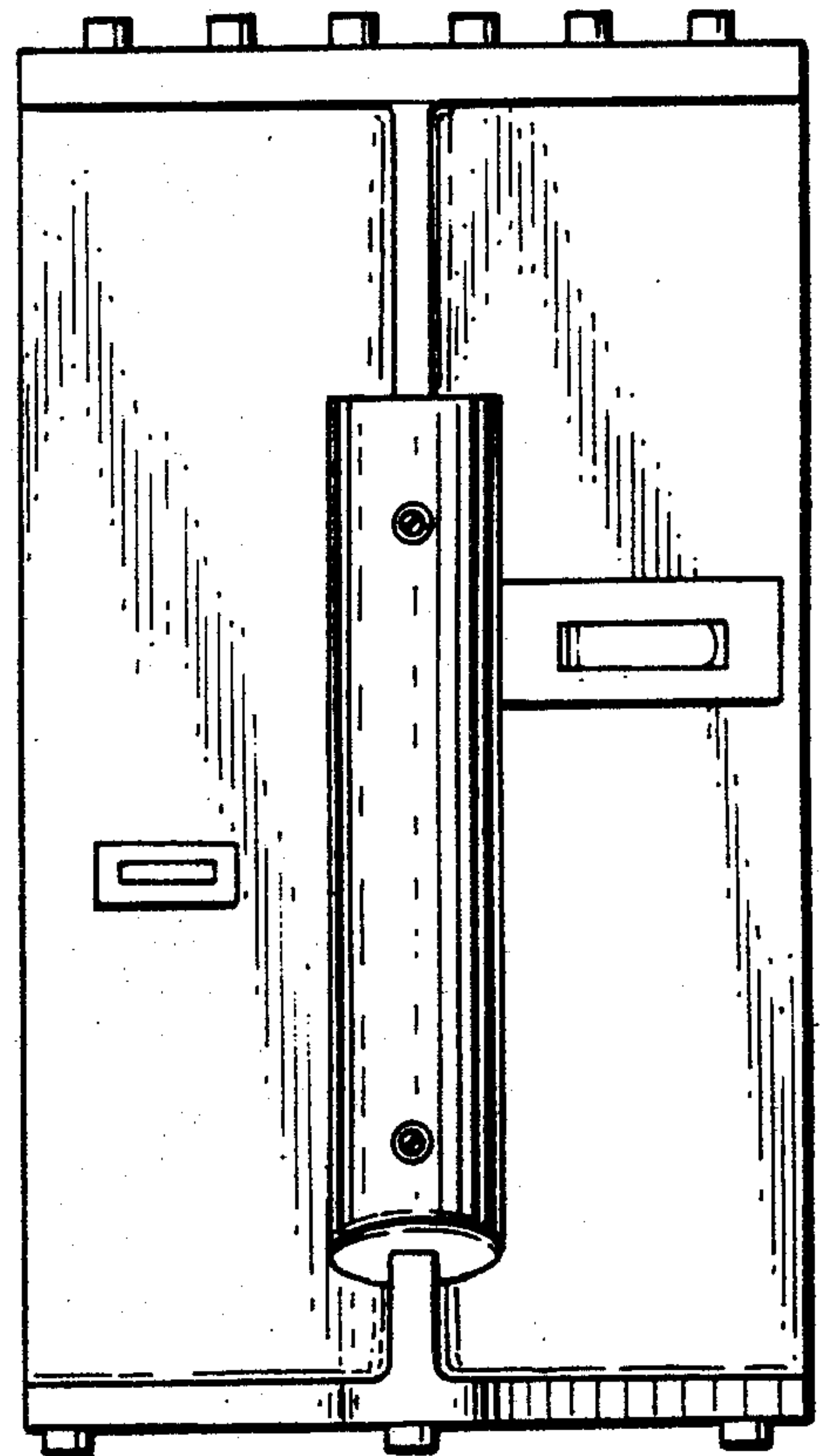

Fig. 5

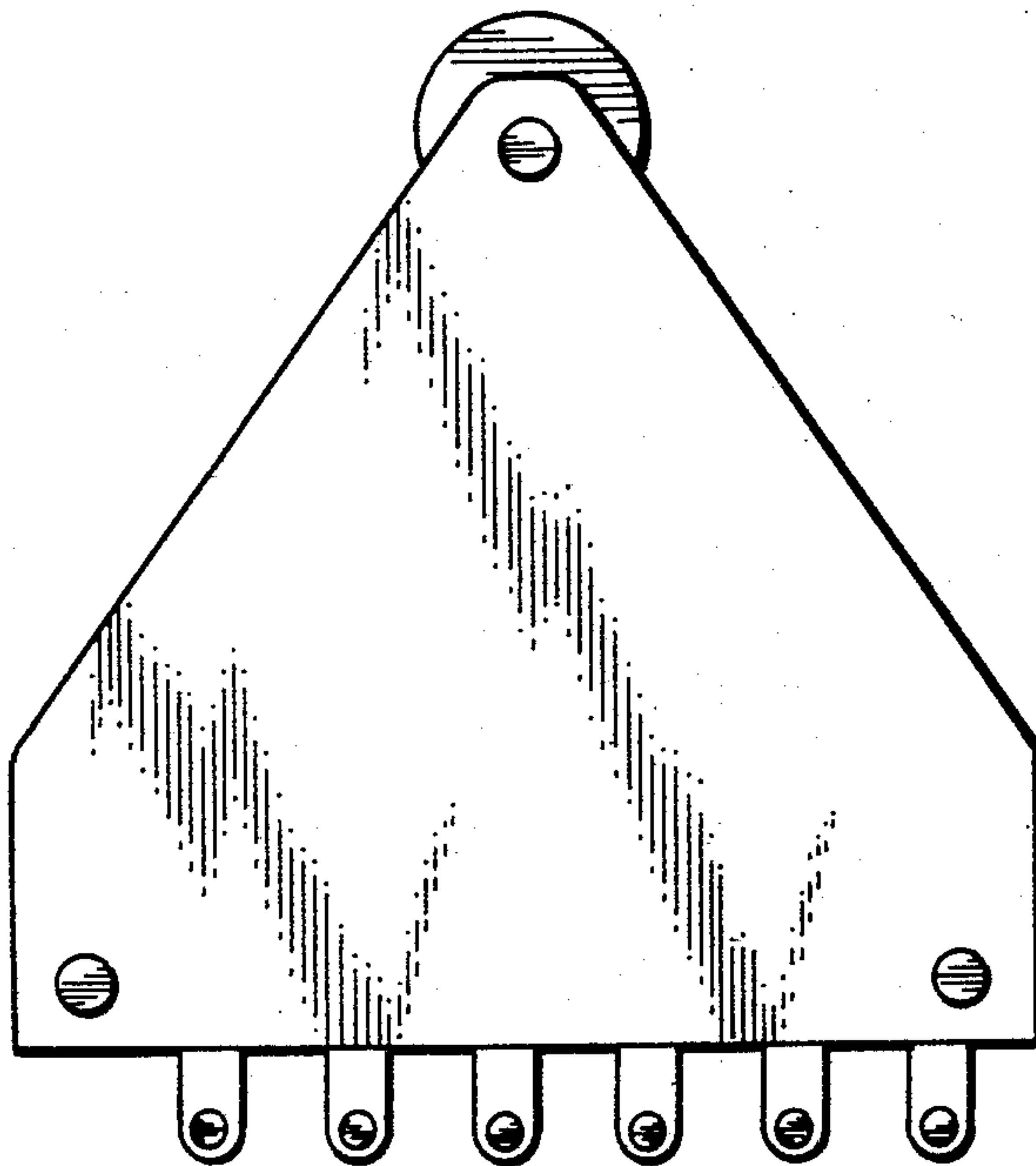

Fig. 6