

[54] **COMBINED PLATFORM TRUCK AND
HAND TRUCK DOLLY**

[76] Inventor: **Phillip G. Ruffin**, 1522 S. Florence,
Wichita, Kans. 67209

[**] Term: **14 Years**

[21] Appl. No.: **635,193**

[22] Filed: **Jul. 27, 1984**

[52] U.S. Cl. **D34/17; D34/26**

[58] Field of Search **D34/17, 26, 23;
280/47.18, 47.27, 47.2, 47.17, 47.34**

[56] **References Cited**

U.S. PATENT DOCUMENTS

D. 249,032	8/1978	Tarran	D34/17
D. 273,522	4/1984	Zastera	D34/26
D. 278,373	4/1985	Rousseau	D34/26
3,785,669	1/1974	Doheny	D34/17
4,009,891	3/1977	Jensen	280/47.2
4,358,124	11/1982	Geschwender	280/47.18

4,588,197 5/1986 Benedetto, Jr. 280/47.27

Primary Examiner—James M. Gandy
Assistant Examiner—Kay H. Chin
Attorney, Agent, or Firm—Phillip A. Rein

[57] **CLAIM**

The ornamental design for a combined platform truck and hand truck dolly, as shown and described.

DESCRIPTION

FIG. 1 is a top plan view of a combined platform truck and hand truck dolly showing my new design; FIG. 2 is a front elevational view thereof; FIG. 3 is a side elevational view thereof with the opposite side thereof being identical; FIG. 4 is a bottom plan view thereof; FIG. 5 is a rear elevational view thereof; FIG. 6 is a perspective view thereof, in an alternate position for use as a container platform truck; FIG. 7 is a perspective view thereof, in an another alternate position for use as a hand truck dolly.

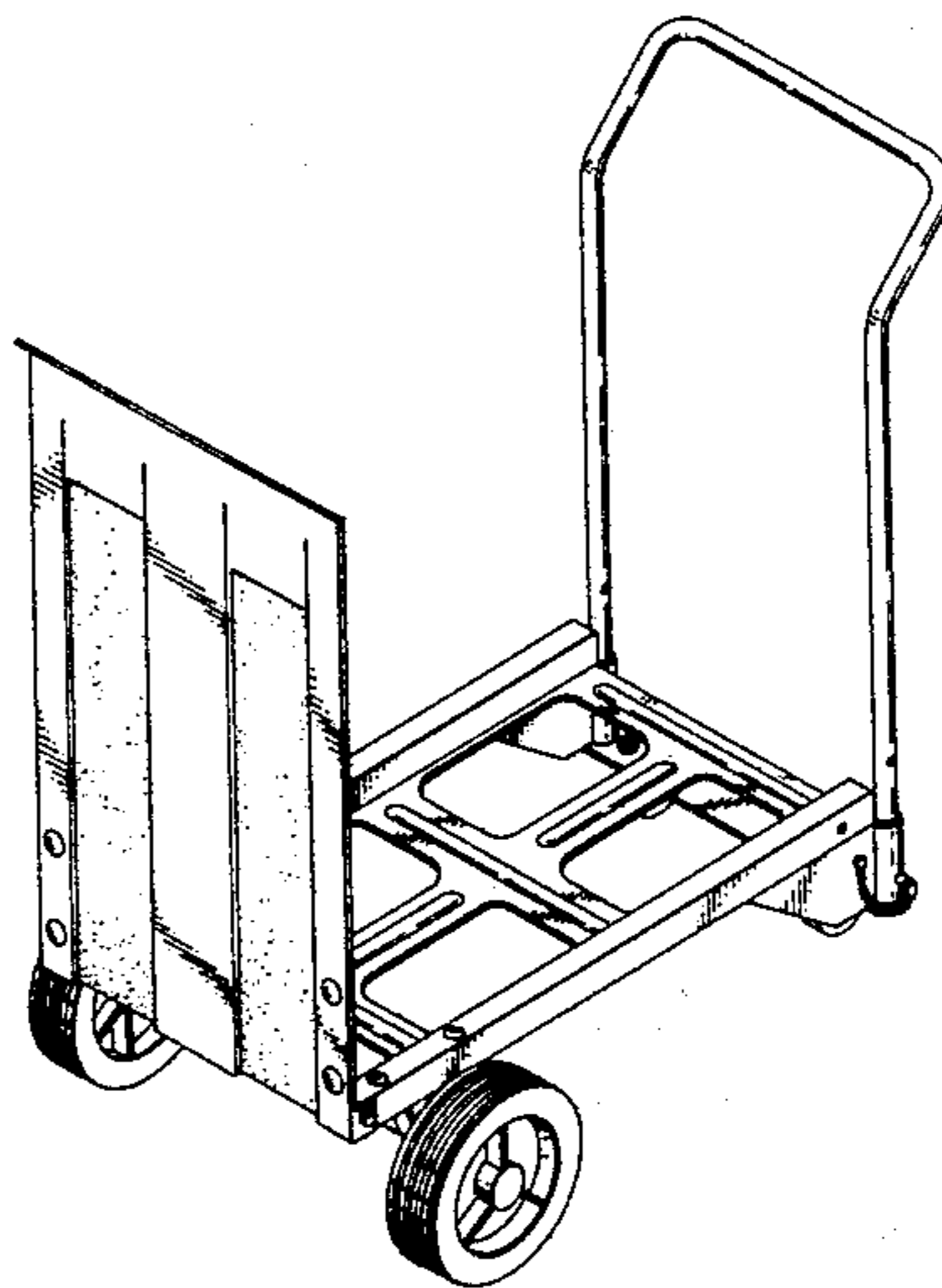

FIG. 1.

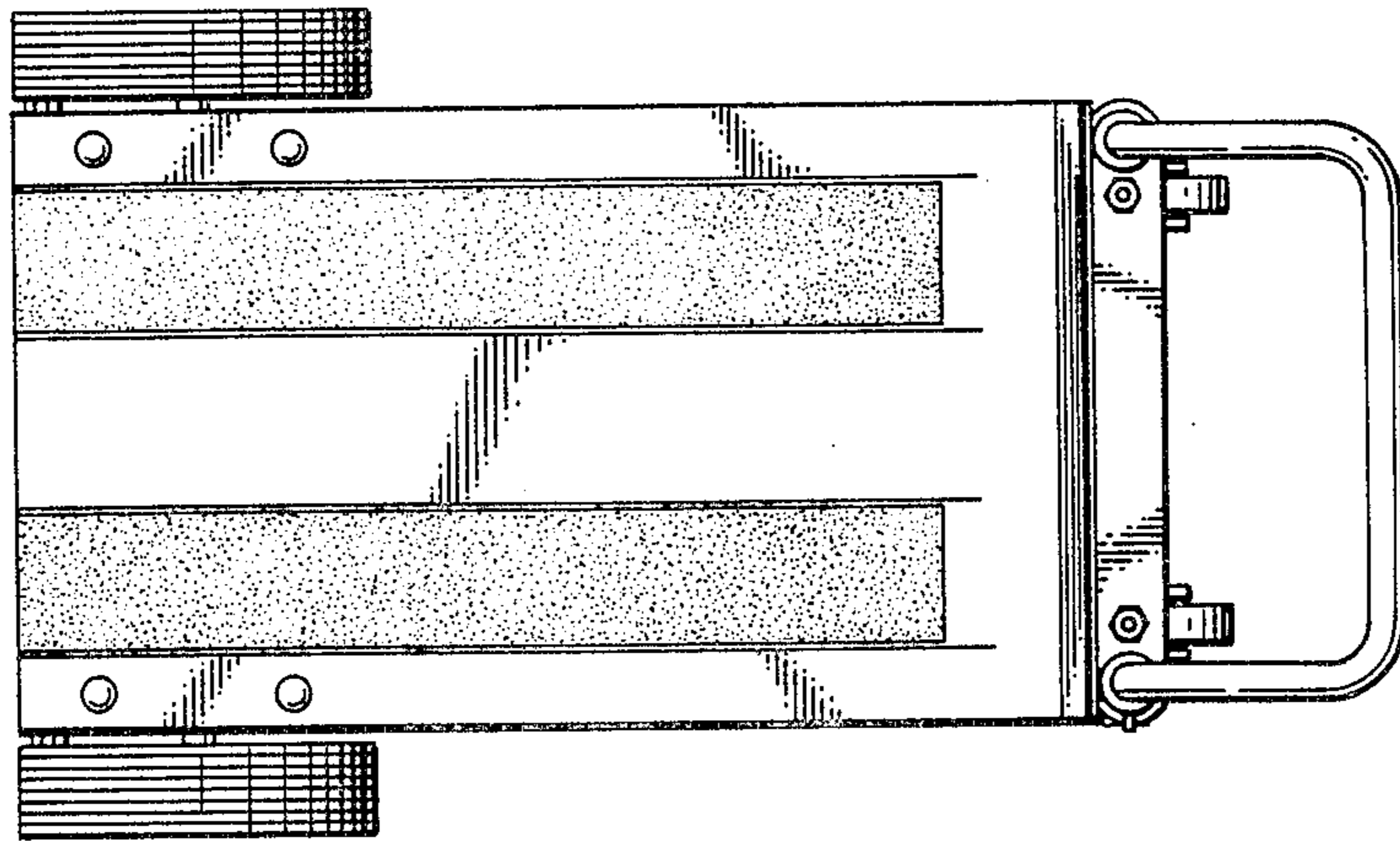

FIG. 2.

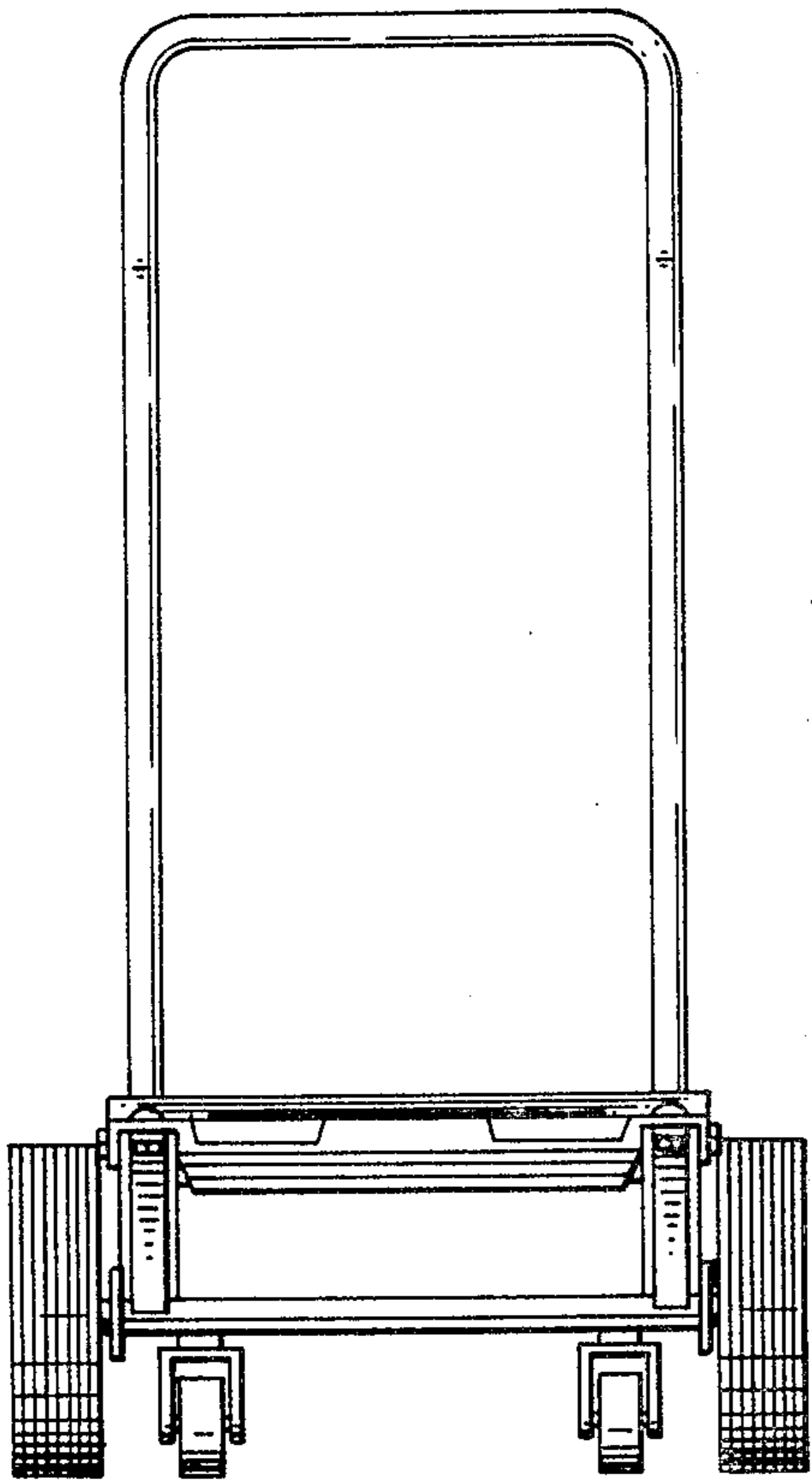

FIG. 3.

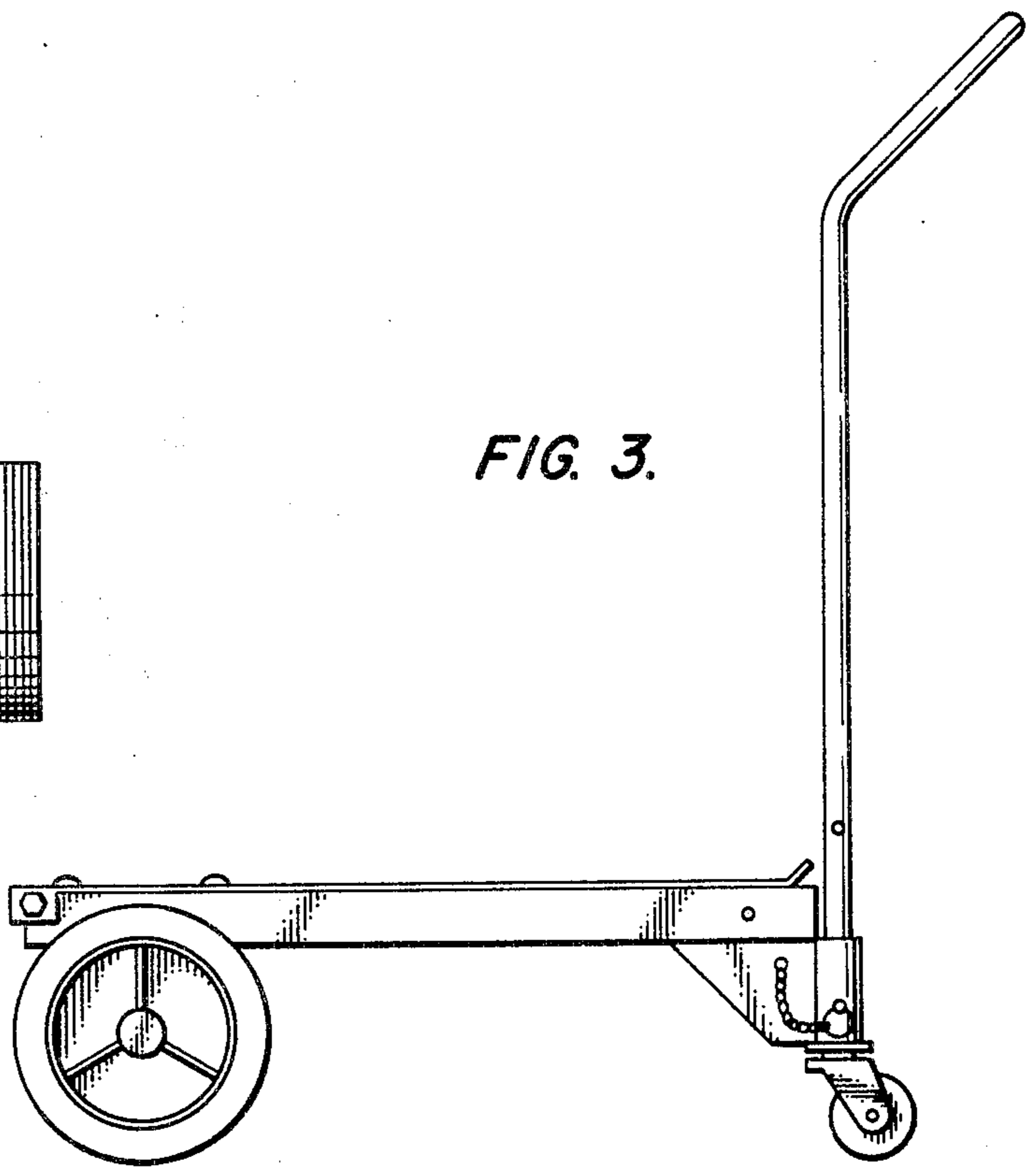

FIG. 4.

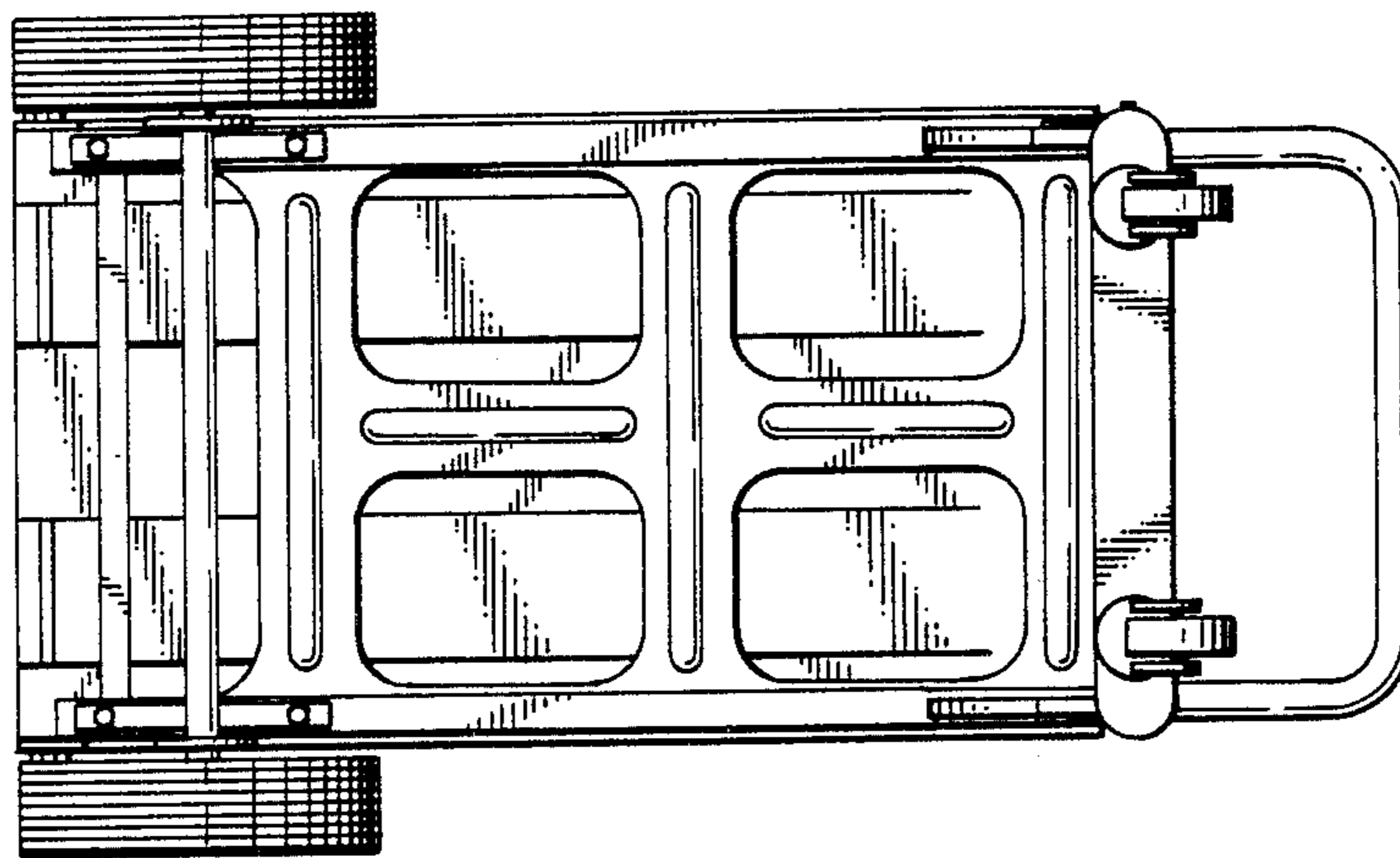

FIG. 6.

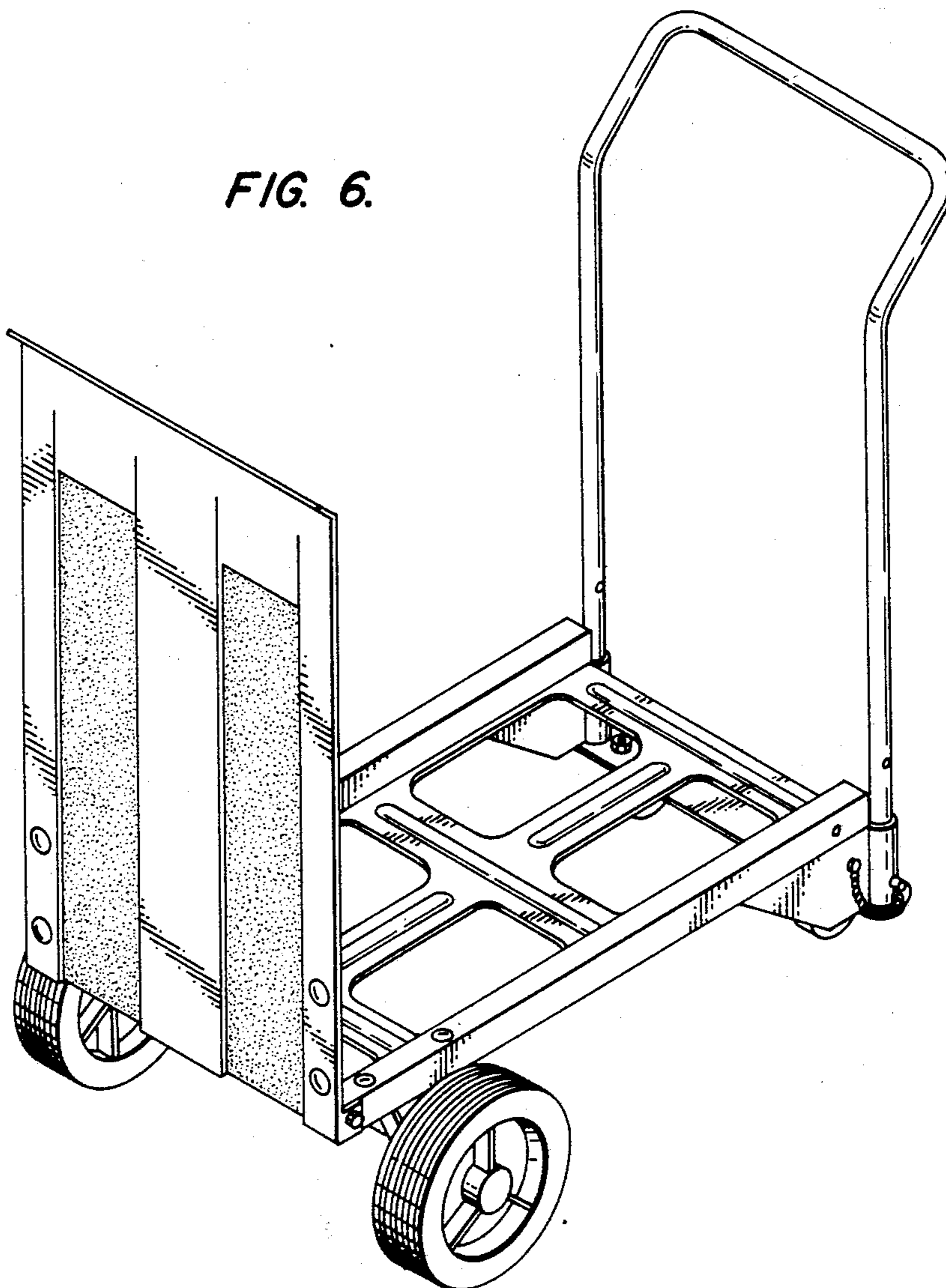

FIG. 5.

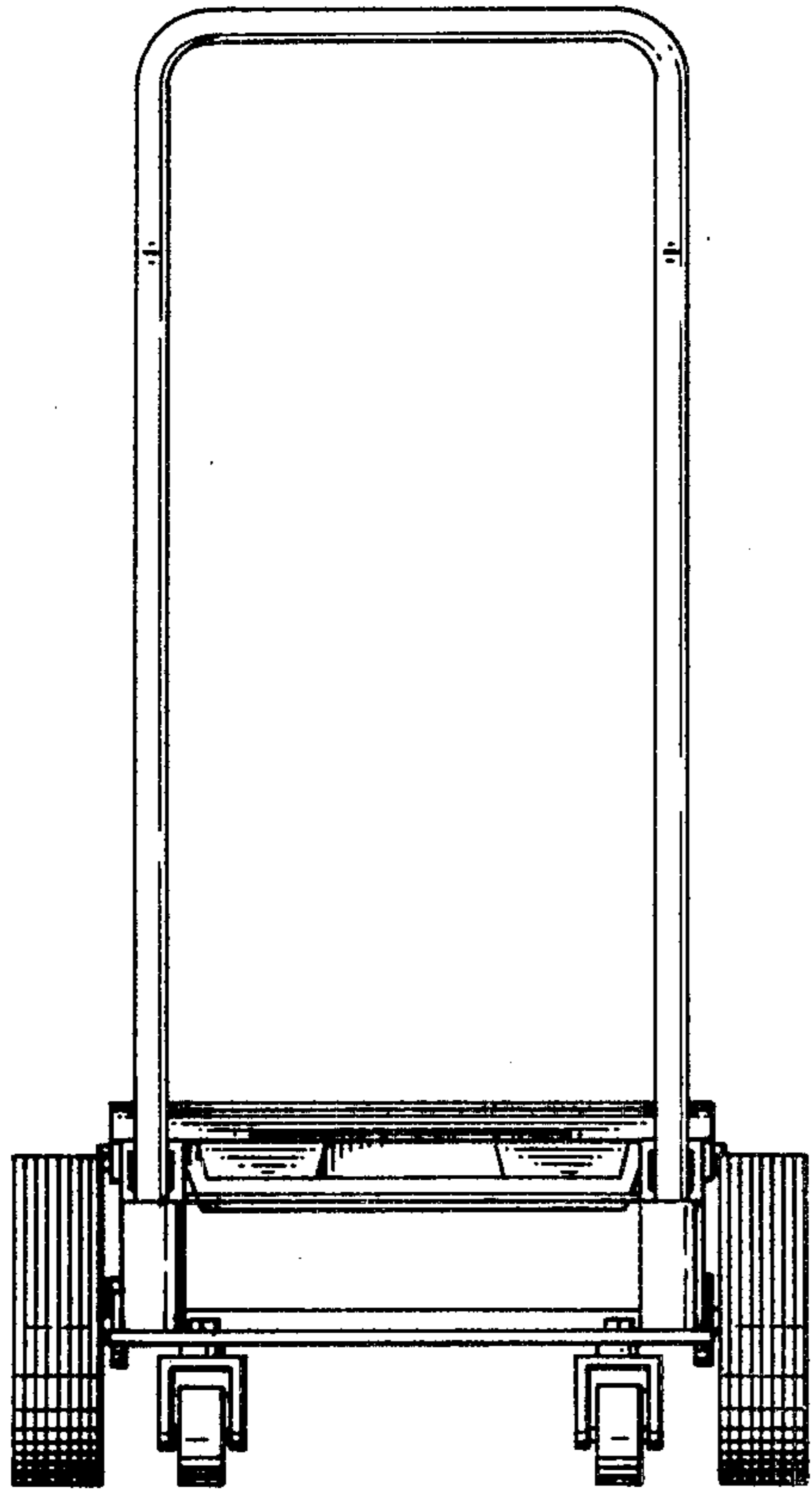

FIG. 7.

