

[54] TIRE FOR A VEHICLE WHEEL

[75] Inventor: Giuliano Ghilardi, Sesto San Giovanni, Italy

[73] Assignee: Societa' Pneumatici Pirelli S.p.A., Italy

[**] Term: 14 Years

[21] Appl. No.: 613,531

[22] Filed: May 24, 1984

[30] Foreign Application Priority Data

Dec. 6, 1983 [IT] Italy 23757/83[U]

[52] U.S. Cl. D12/142

[58] Field of Search D12/141-143; 152/209 R, 209 D

[56] References Cited

PUBLICATIONS

1979 Tread Design Guide, p. 172, Pirelli SN 55, US Tire, top center of page.

1983 Tread Design Guide, p. 149, Alliance All Steel Radial 245 Tire, top center of page. Modern Tire Dealer, 8/83, p. 39, Michelin Tire, center of page.

Primary Examiner—James M. Gandy
Attorney, Agent, or Firm—Stevens, Davis, Miller & Mosher

[57] CLAIM

The ornamental design for a tire for a vehicle wheel, as shown and described.

DESCRIPTION

FIG. 1 is a perspective view of a tire for a vehicle wheel showing my new design it being understood that the tread pattern is repeated throughout the circumference of the tire as shown schematically by solid line, the opposite side being the same as that shown; FIG. 2 is a front elevational view thereof; and FIG. 3 is a side elevational view thereof on a reduced scale, the opposite side being a mirror image of that shown.

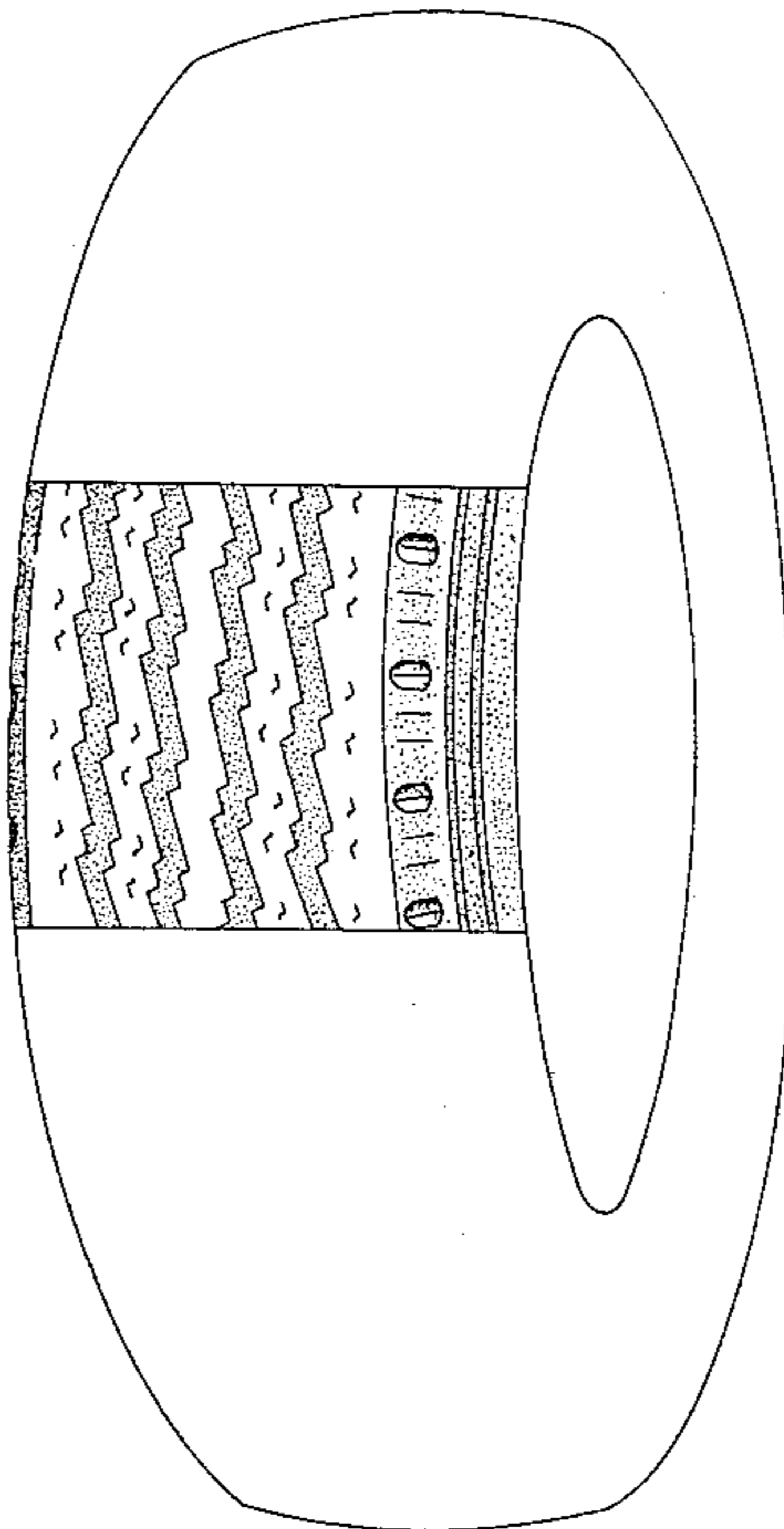

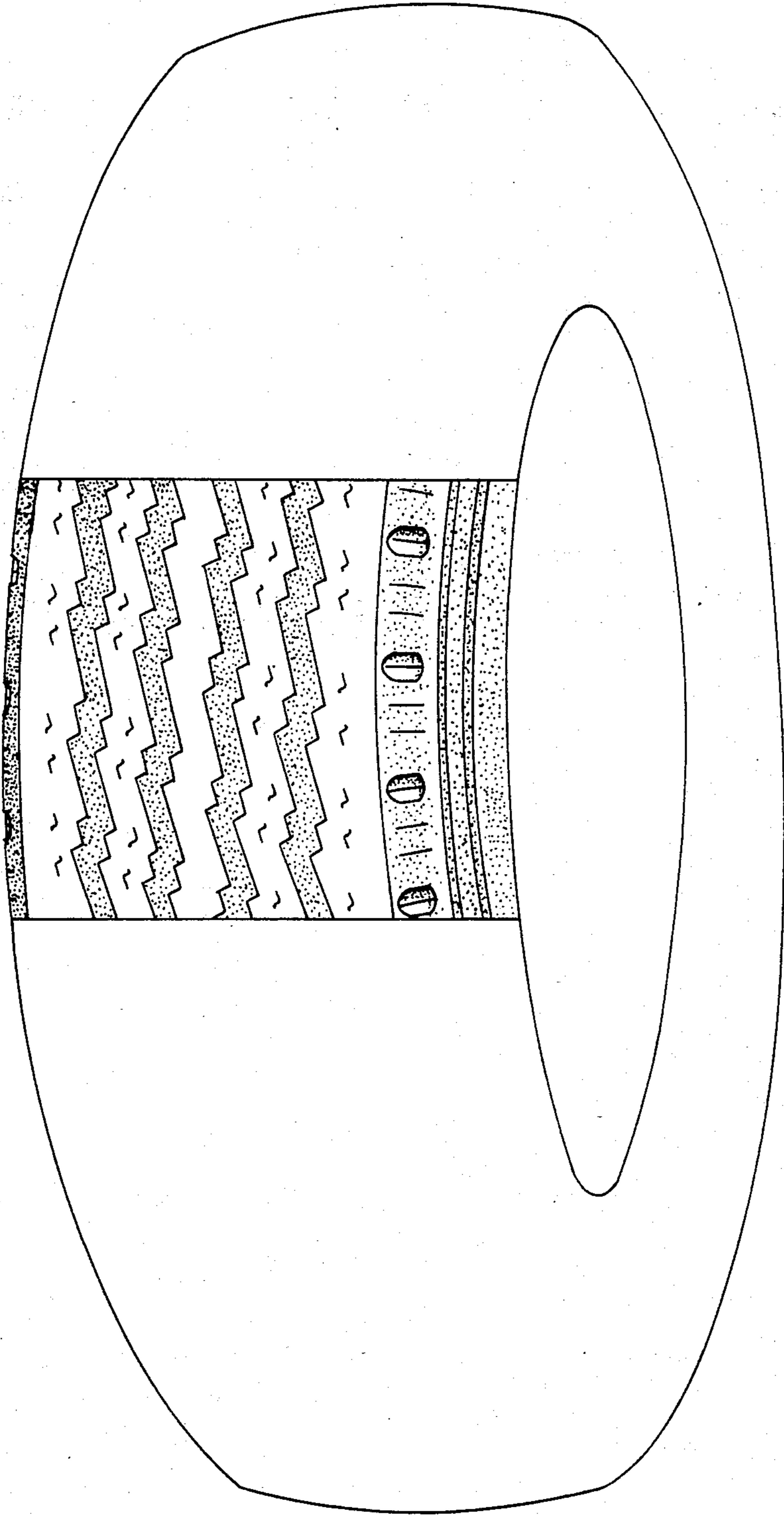

FIG 1

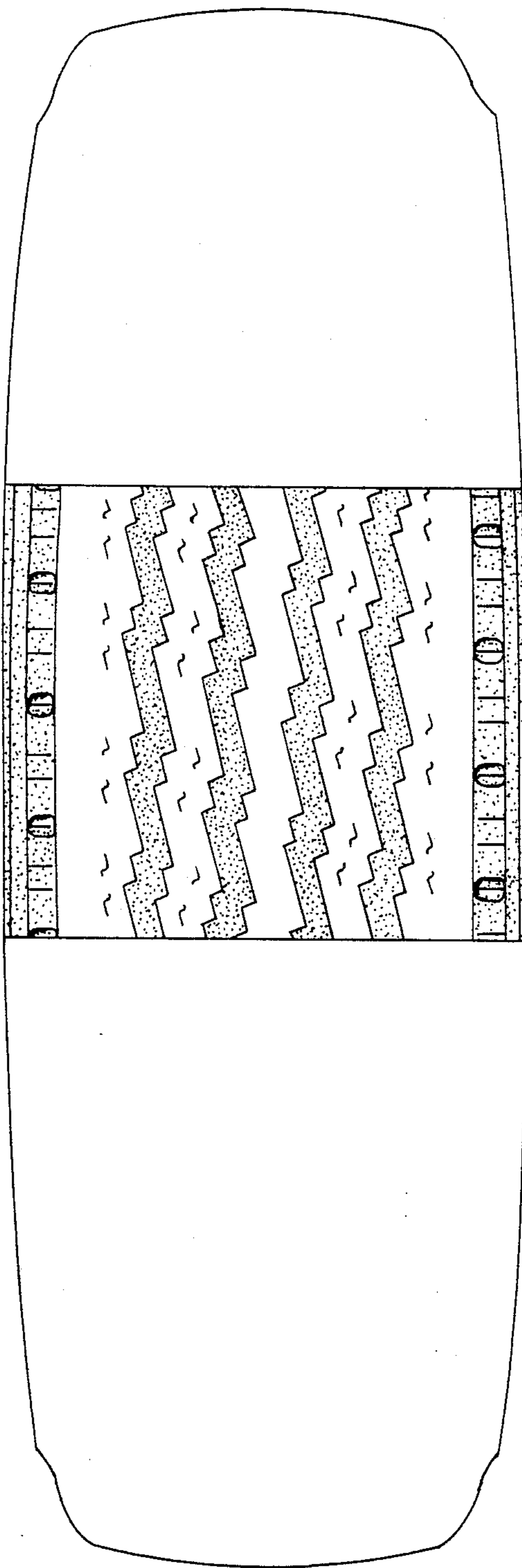

FIG 2

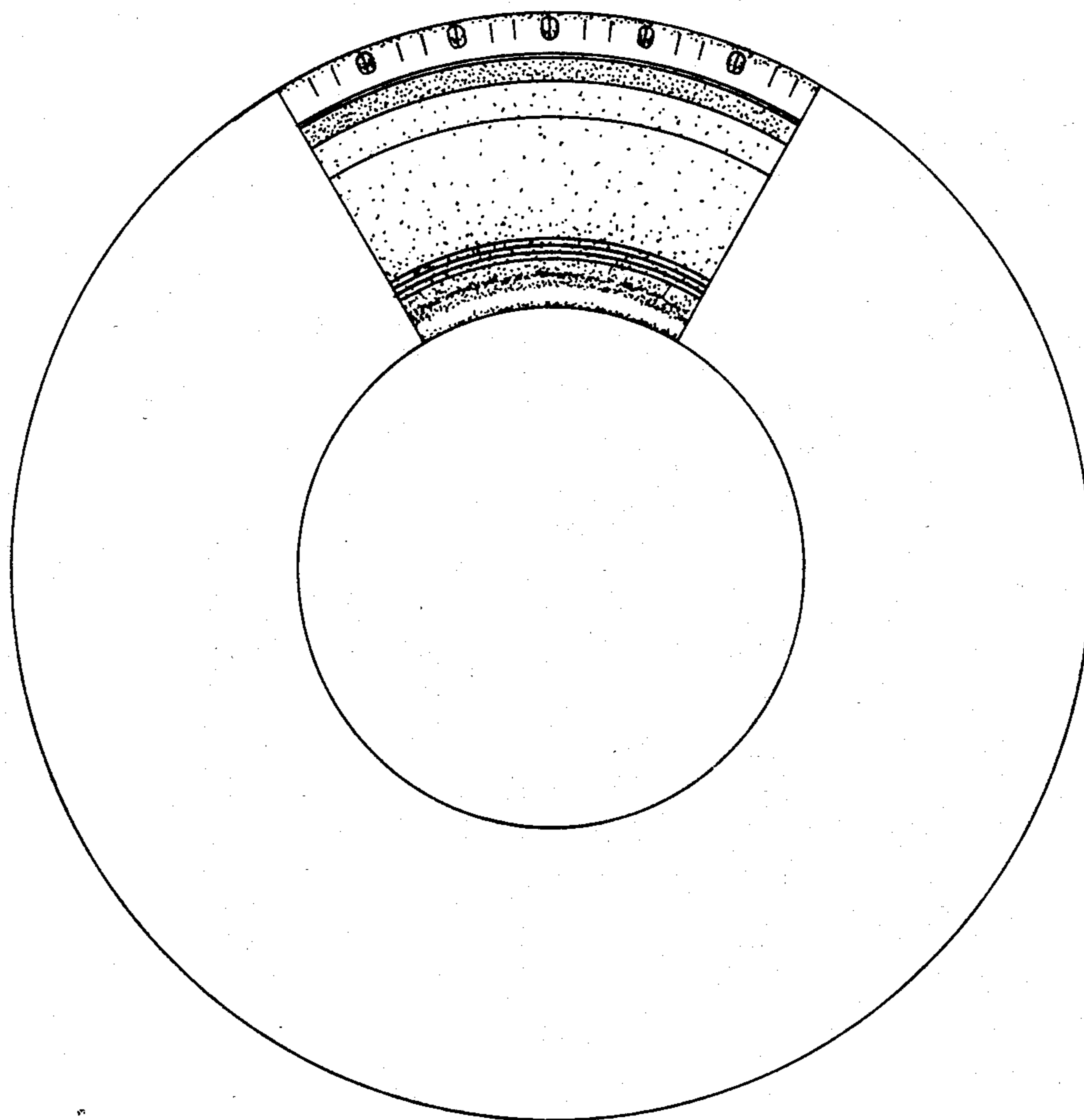

FIG 3