

[54] **ELECTRONIC KEYBOARD MUSICAL INSTRUMENT**

[75] **Inventor: Mario Bellini, Milan, Italy**

[73] **Assignee: Nippon Gakki Seizo Kabushiki Kaisha, Shizuoka, Japan**

[**] **Term: 14 Years**

[21] **Appl. No.: 619,019**

[22] **Filed: Jun. 11, 1984**

[30] **Foreign Application Priority Data**

Dec. 17, 1983 [JP] Japan 58-54413
[52] **U.S. Cl.** **D17/1; D17/5**
[58] **Field of Search** **D17/1, 2, 5, 6, 7, 99; 84/DIG. 7, 1.1, 1.01, 423 R, 433**

[56] **References Cited**

U.S. PATENT DOCUMENTS

D. 222,113 9/1971 Novaco D17/5
D. 265,832 8/1982 Kira et al. D17/5
D. 276,534 11/1984 Bontempi D17/6
D. 282,850 4/1986 Futami D17/1

OTHER PUBLICATIONS

Music Trades, June 1983, p. 37, Korg Personal Keyboard.

Music Trades, Feb. 1983, p. 65, Casiotone 701 Keyboard.

Primary Examiner—Bernard Ansher
Assistant Examiner—Theodore M. Shooman
Attorney, Agent, or Firm—Weingarten, Schurgin, Gagnebin & Hayes

[57] **CLAIM**

The ornamental design for electronic keyboard musical instrument, as shown and described.

DESCRIPTION

FIG. 1 is a top, front and right side perspective view of an electronic keyboard musical instrument showing my new design;

FIG. 2 is a bottom, rear and left side perspective view thereof;

FIG. 3 is a right side elevational view thereof;

FIG. 4 is a top plan view thereof;

FIG. 5 is a front elevational view thereof; and

FIG. 6 is a top, front and right side perspective view thereof, illustrated with the cover and speakers in the closed position.

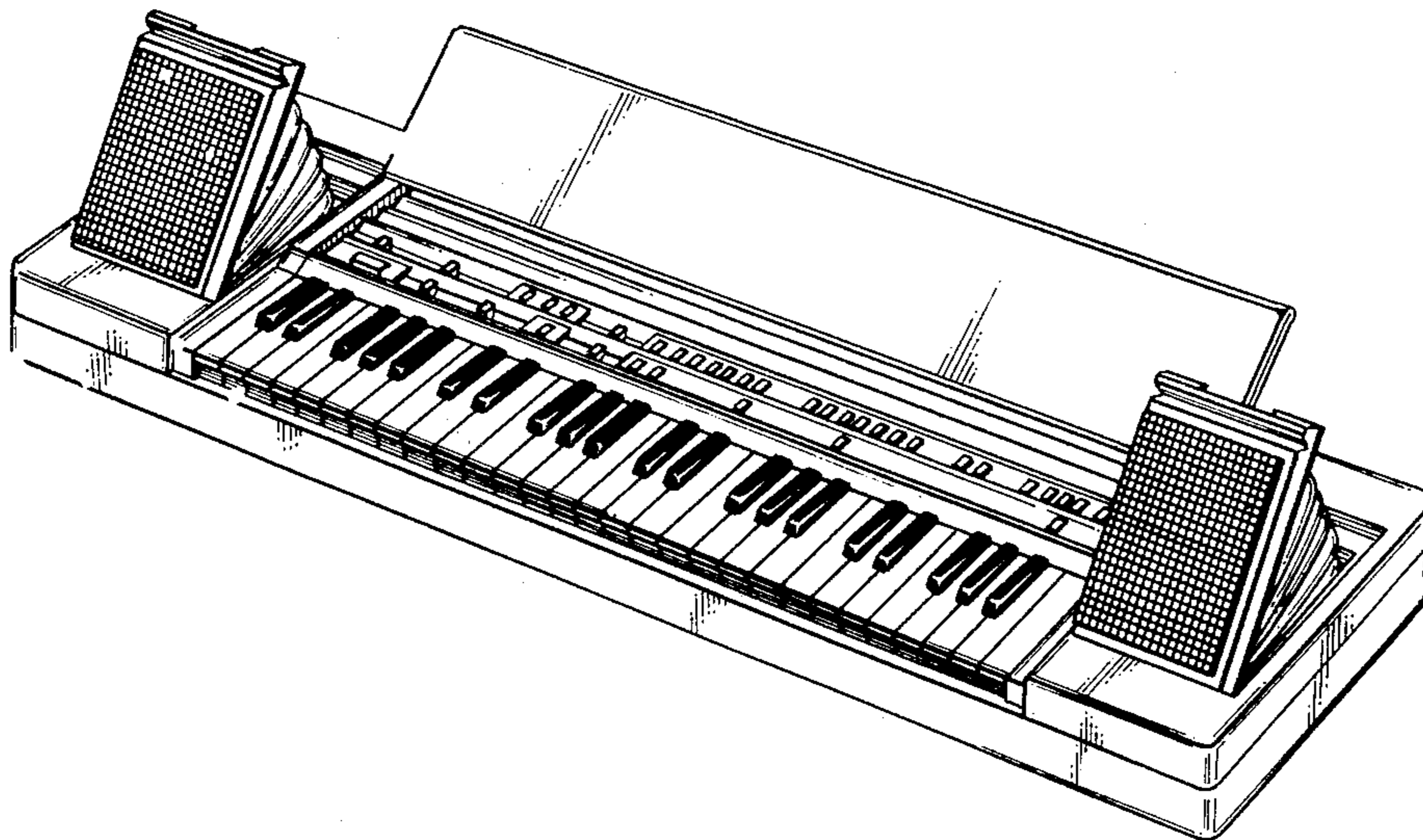

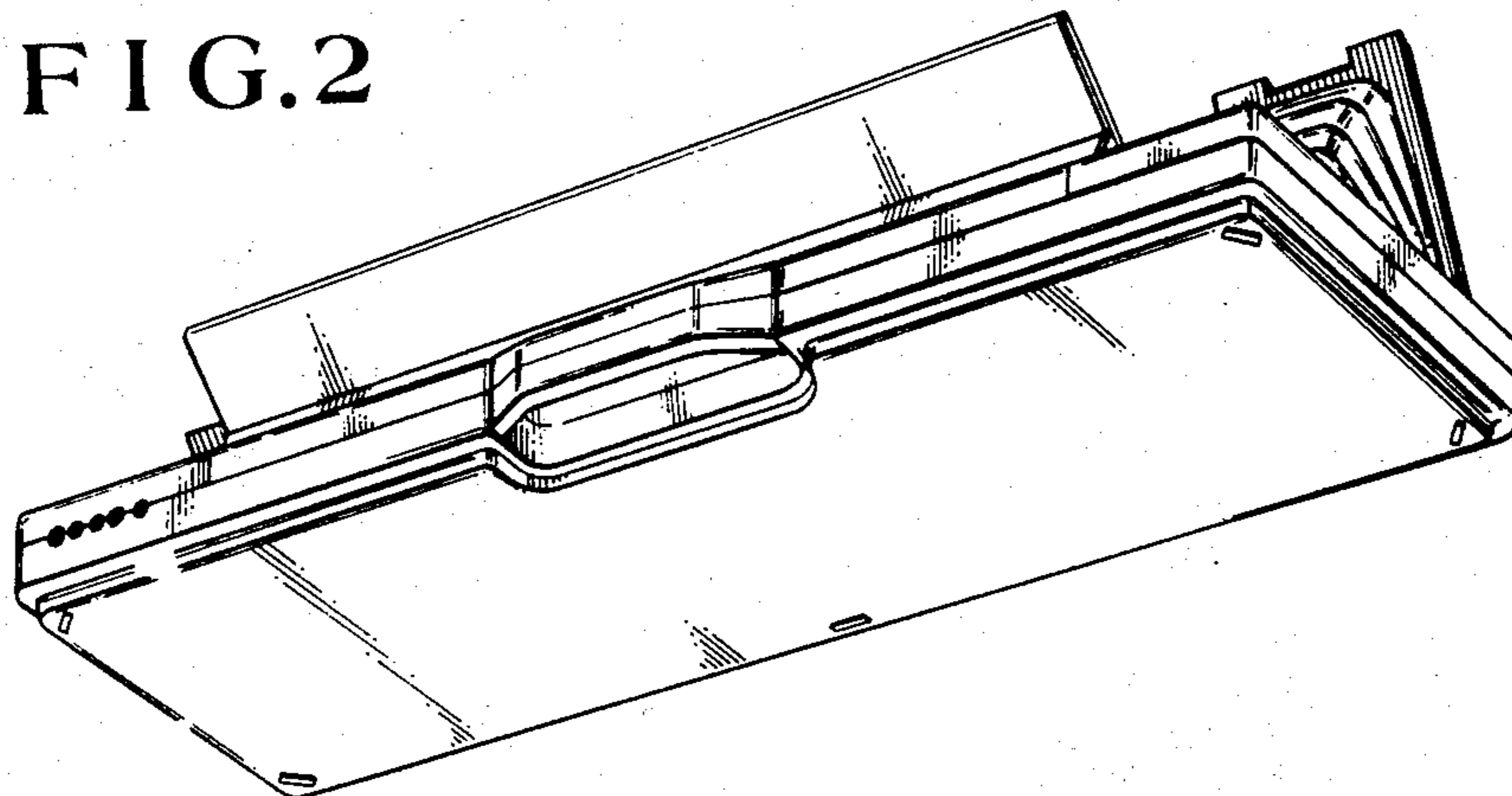
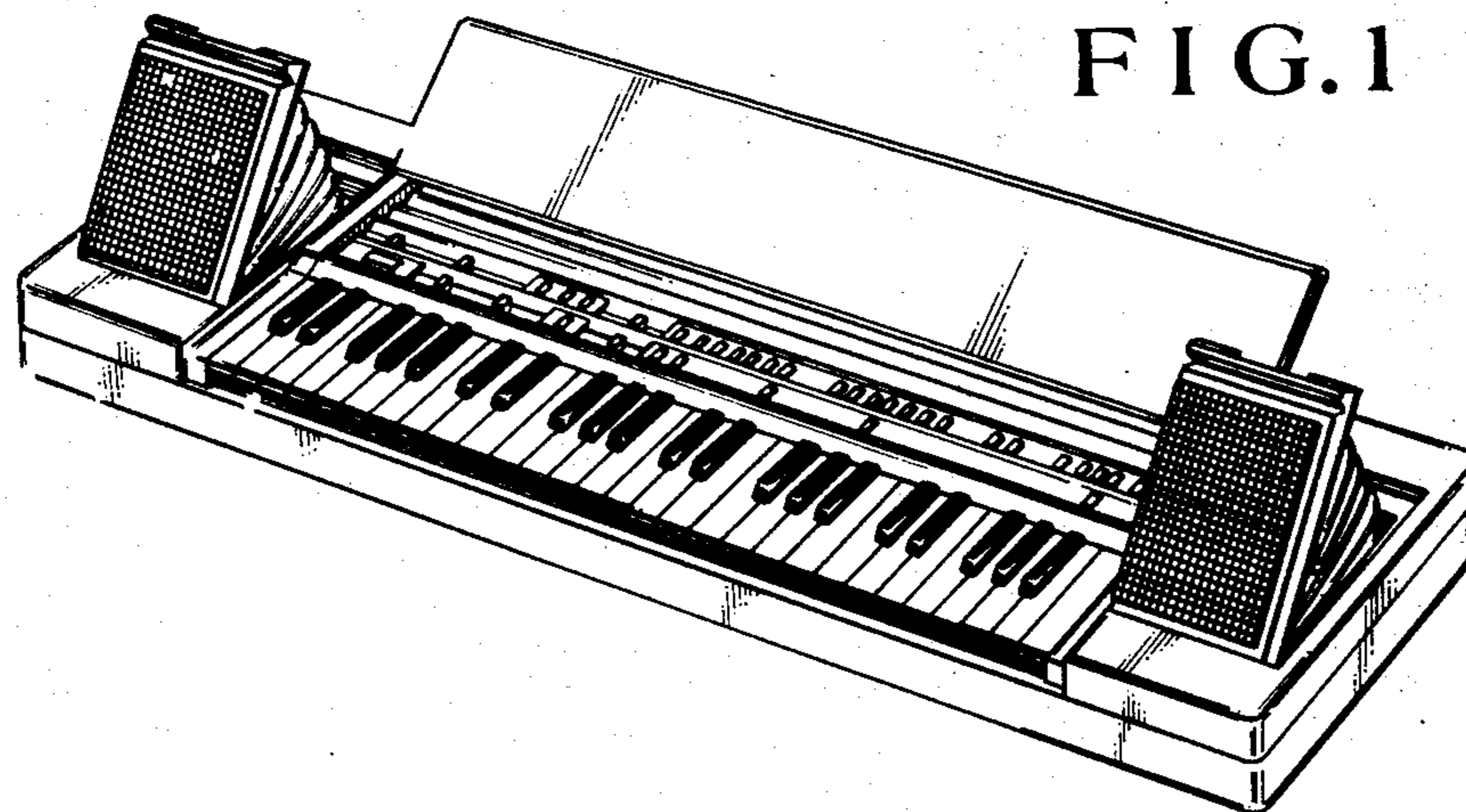

FIG. 3

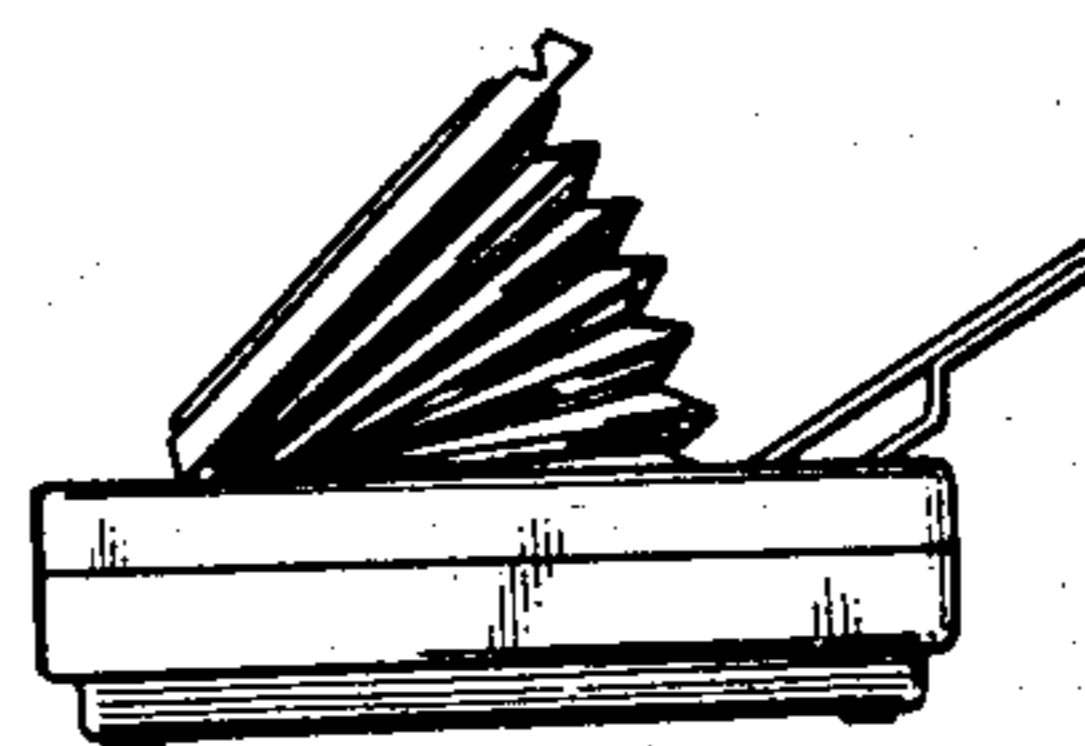

FIG. 4

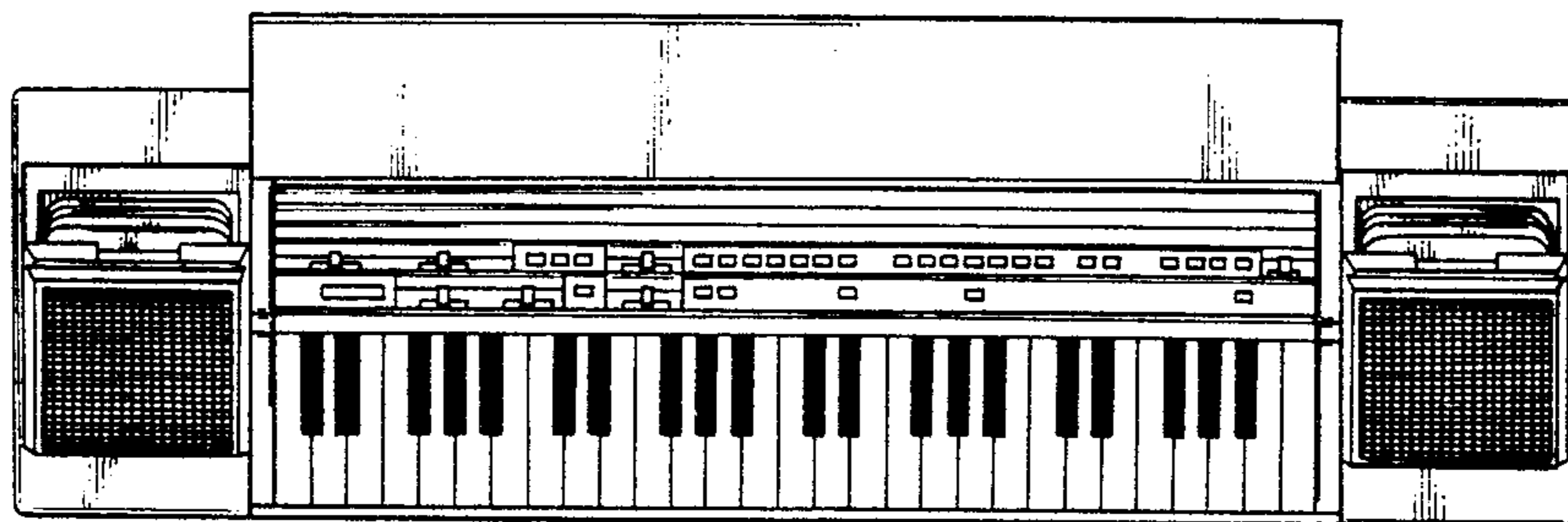

FIG. 5

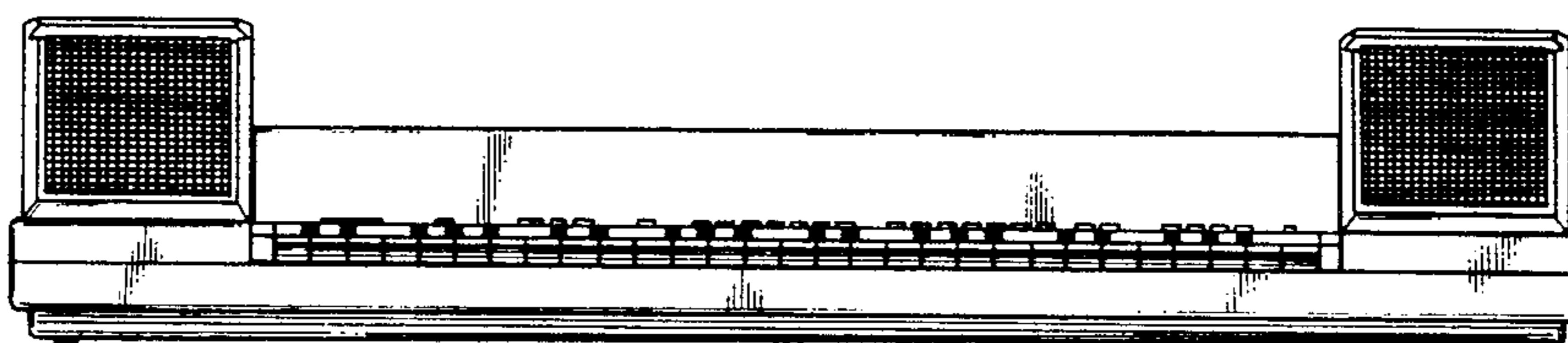

FIG. 6

