

# United States Patent [19]

Gary et al.

[11] Patent Number: **Des. 289,392**

[45] Date of Patent: **\*\* Apr. 21, 1987**

[54] SAILBOAT

[76] Inventors: **Harold L. Gary; Douglas B. Gary,**  
both of 887 Silverpines, Houston,  
Tex. 77062

[\*\*] Term: **14 Years**

[21] Appl. No.: **619,024**

[22] Filed: **Jun. 11, 1984**

[52] U.S. Cl. .... **D12/304**

[58] Field of Search ..... **D12/300, 302, 303, 304,**  
**D12/306; 114/61, 39, 39 R, 283**

[56] **References Cited**

**U.S. PATENT DOCUMENTS**

D. 185,822	8/1959	Hall	.....	D71/1
3,016,861	1/1962	Brown	.....	114/61
3,139,058	6/1964	Robinson	.....	114/61
3,236,202	2/1966	Quady et al.	.....	114/66.5
3,265,026	8/1966	Hamilton	.....	114/61
3,430,595	3/1969	Tulleners	.....	114/61
3,517,632	6/1970	Gray	.....	114/61
3,604,382	9/1971	Sorrenti	.....	114/61
3,788,257	1/1974	Miller	.....	114/39
3,910,214	10/1975	Holter	.....	114/61

3,917,022	11/1975	Brooks, Jr.	.....	114/61
4,286,533	9/1981	Sanner	.....	114/61
4,392,444	7/1983	Andersson	.....	114/39
4,562,785	1/1986	Priam-Doizi	.....	114/39

*Primary Examiner*—James M. Gandy  
*Assistant Examiner*—Kay H. Chin  
*Attorney, Agent, or Firm*—Arnold, White & Durkee

[57] **CLAIM**

The ornamental design for a sailboat, as shown and described.

**DESCRIPTION**

FIG. 1 is a perspective view of a sailboat showing our new design;  
FIG. 2 is a side elevational view thereof, the opposite side being a mirror image of that shown;  
FIG. 3 is a rear elevational view thereof;  
FIG. 4 is a front elevational view thereof;  
FIG. 5 is a top plan view thereof;  
FIG. 6 is a bottom plan view thereof.  
The broken line illustration of a mast and sail shown in FIGS. 1 and 2, and a mast shown in FIGS. 3 and 4 is for illustrative purposes only and forms no part of the claimed design.

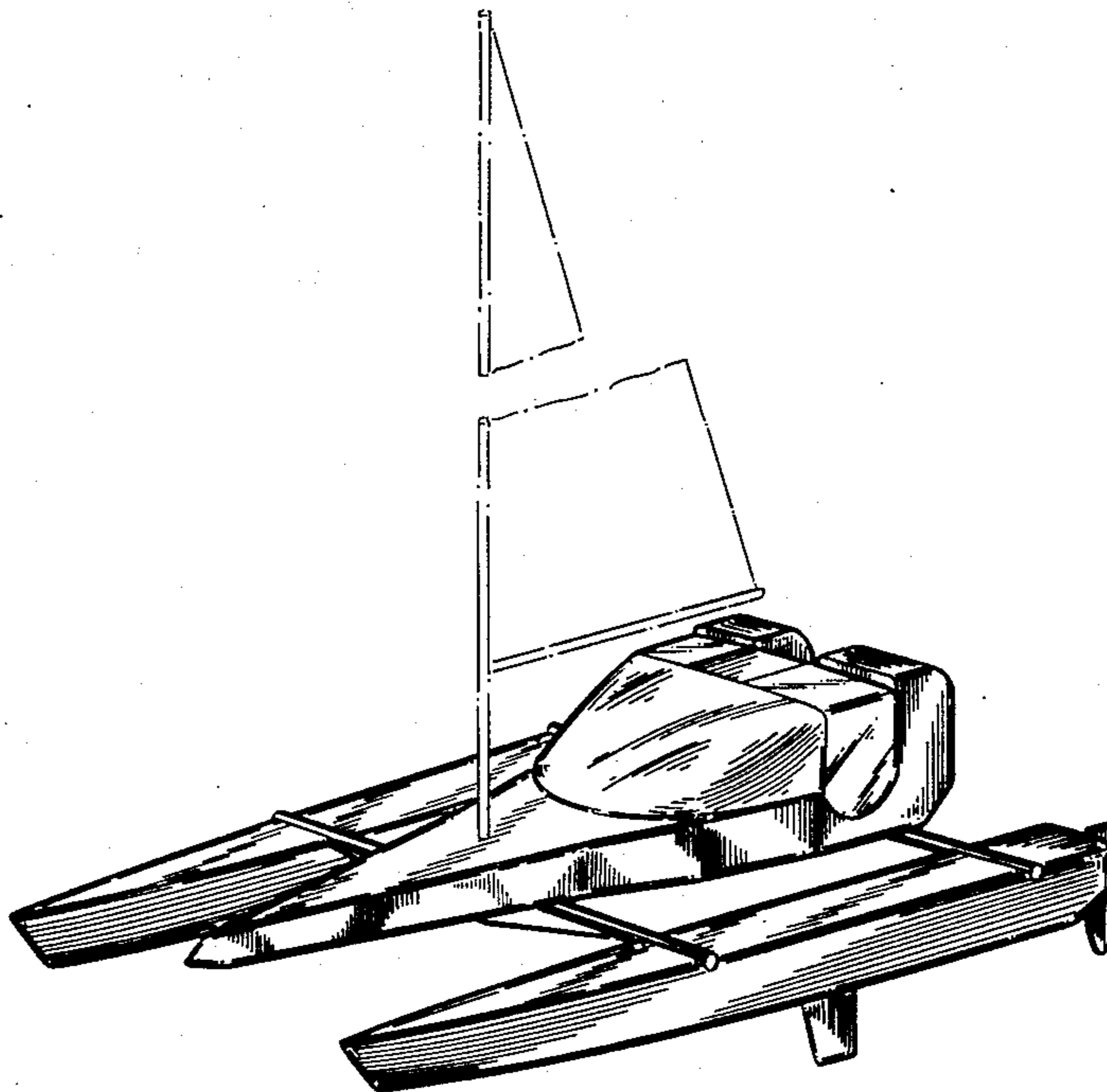

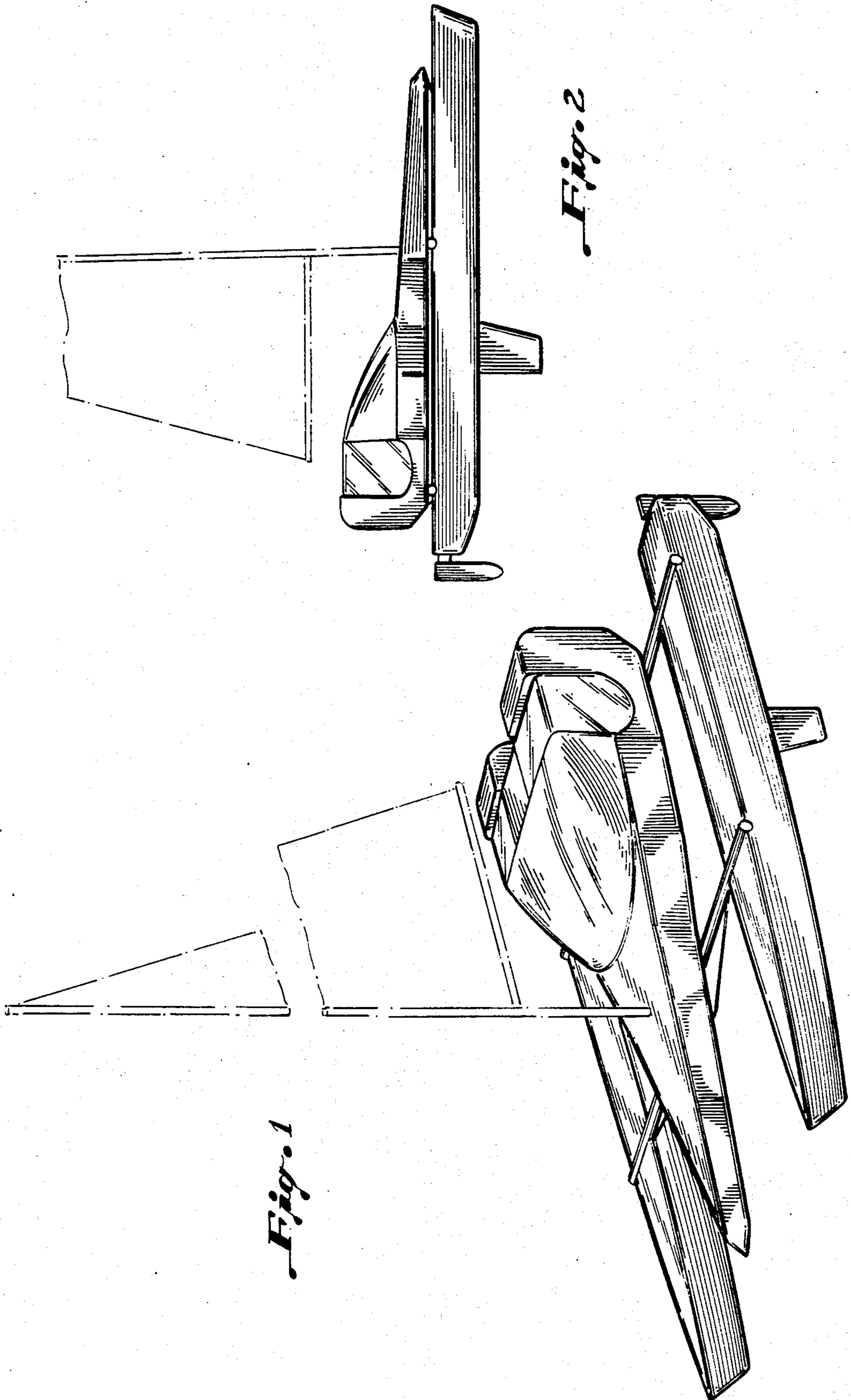

*Fig. 1*

*Fig. 2*

