

[54] **OUTBOARD MOTOR**

[75] **Inventors:** Yoshio Mikado, Saitama; Jun Ito; Masayuki Ohsumi, both of Tokyo, all of Japan

[73] **Assignee:** Honda Giken Kogyo Kabushiki Kaisha, Tokyo, Japan

[*] **Notice:** The portion of the term of this patent subsequent to Apr. 7, 2001 has been disclaimed.

[**] **Term:** 14 Years

[21] **Appl. No.:** 683,408

[22] **Filed:** Dec. 19, 1984

[30] **Foreign Application Priority Data**

Jun. 19, 1984 [JP]	Japan	59-25258
[52] U.S. Cl.		D15/4
[58] Field of Search		D15/4; 206/319;
		123/195 C, 195 P; 440/49-53, 59, 63, 76, 77, 78, 84, 900

[56] **References Cited**

U.S. PATENT DOCUMENTS

D. 175,270	8/1955	Painter	D15/4
4,507,090	3/1985	Kobayashi et al.	440/52

OTHER PUBLICATIONS

Johnson Engine Catalogue (Feb. 1977), p. 24--"Seahorse 4".
Ocean Life (3/20/84) p. 329--"Tohatsu 12", #M12C Outboard Engine.

Primary Examiner—Wallace R. Burke
Assistant Examiner—Brian N. Vinson
Attorney, Agent, or Firm—Irving M. Weiner; Joseph P. Carrier; Pamela S. Burt

[57] **CLAIM**

The ornamental design for an outboard motor, as shown.

DESCRIPTION

FIG. 1 is a front elevational view of an outboard motor showing our new design;
FIG. 2 is a rear elevational view thereof;
FIG. 3 is a left side elevational view thereof;
FIG. 4 is a right side elevational view thereof;
FIG. 5 is a top plan view thereof; and
FIG. 6 is a bottom plan view thereof.

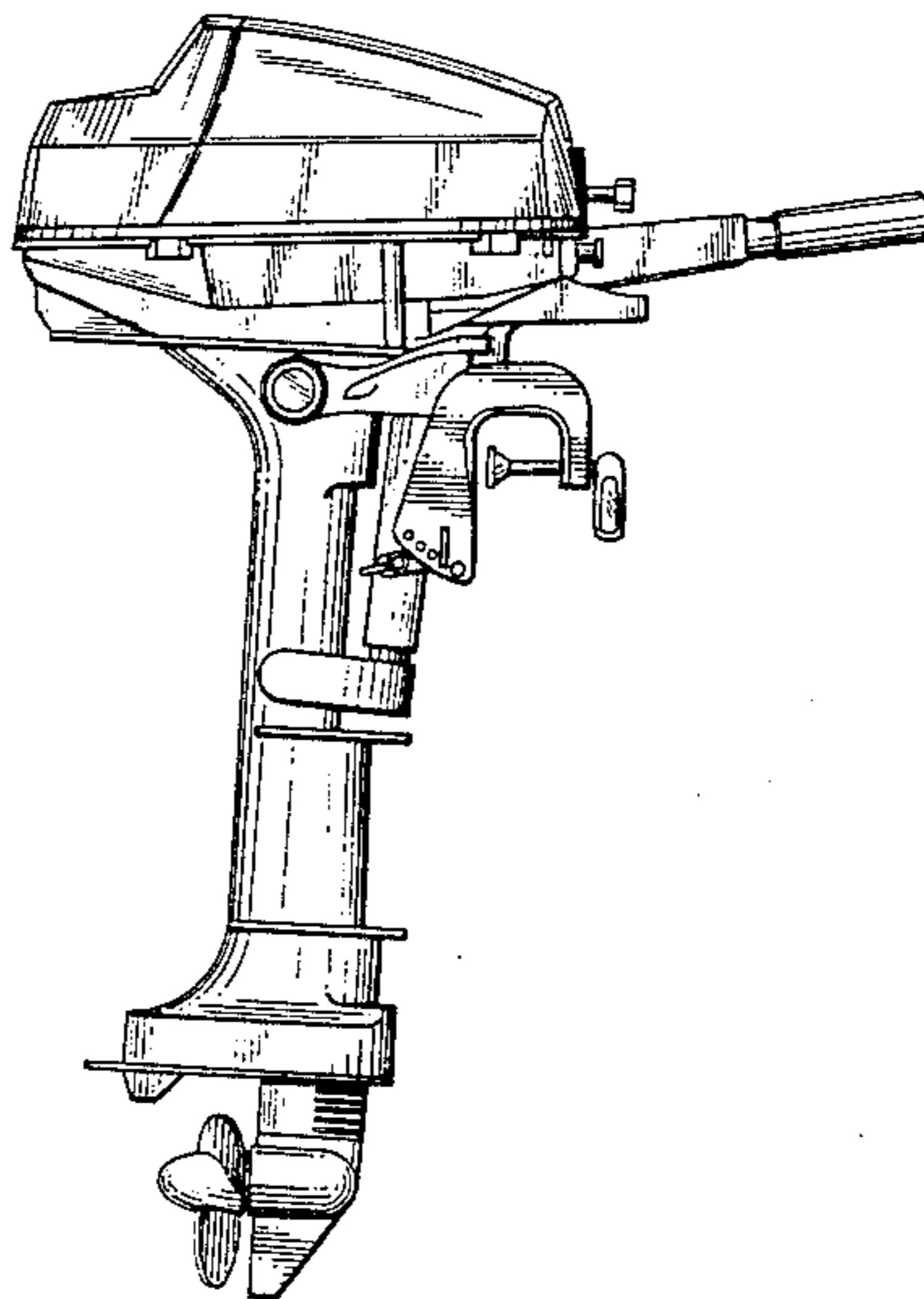

FIG. 1

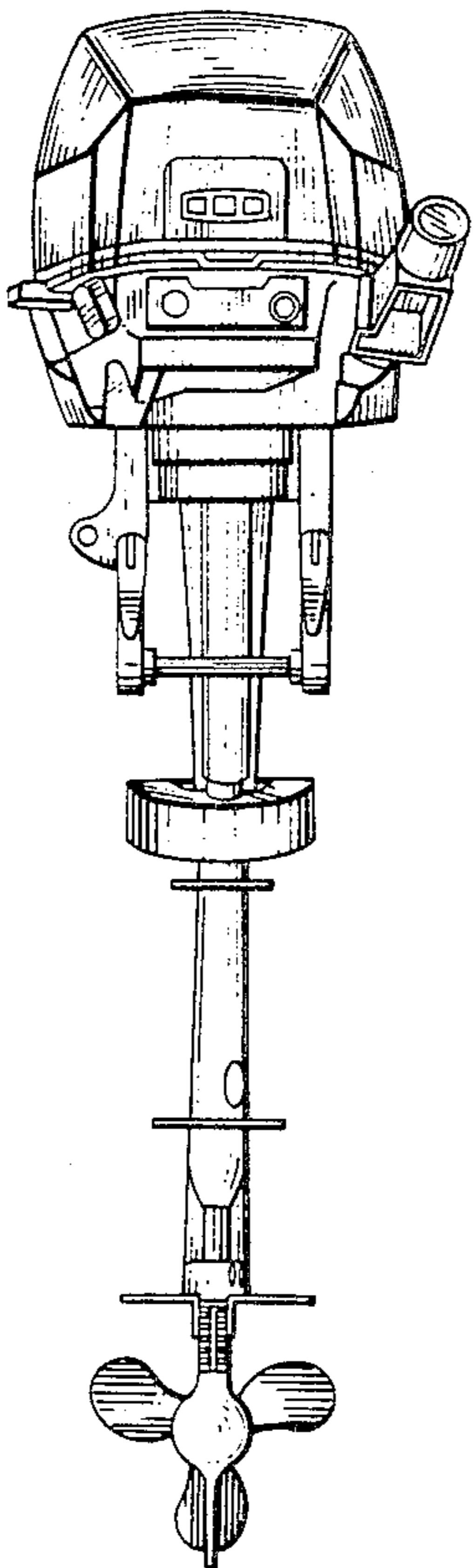

FIG. 2

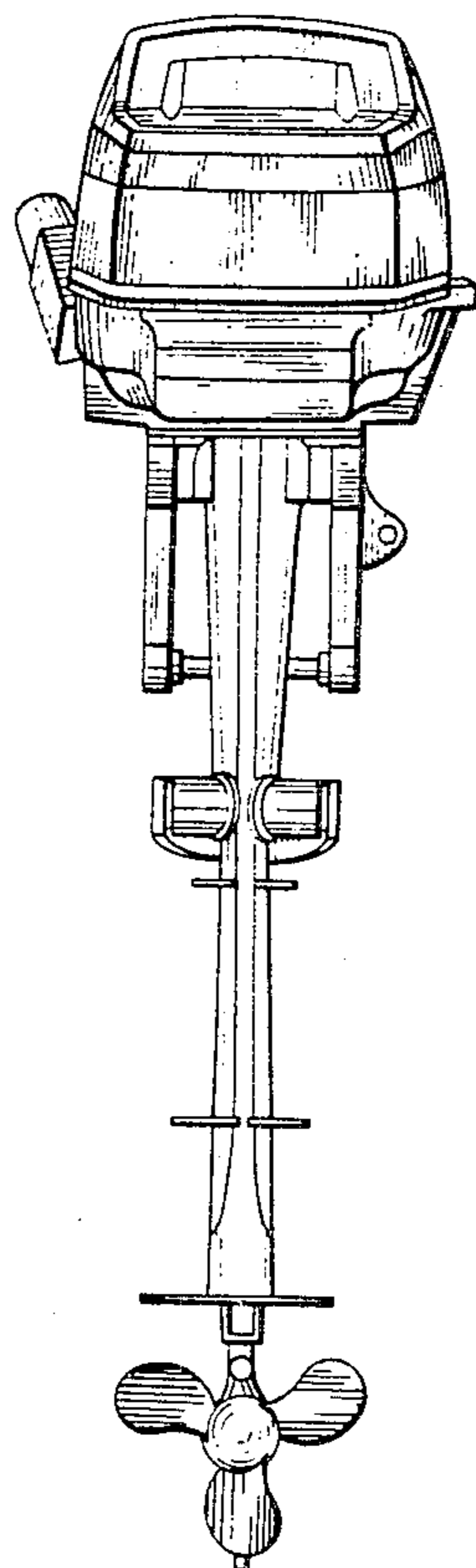

FIG. 3

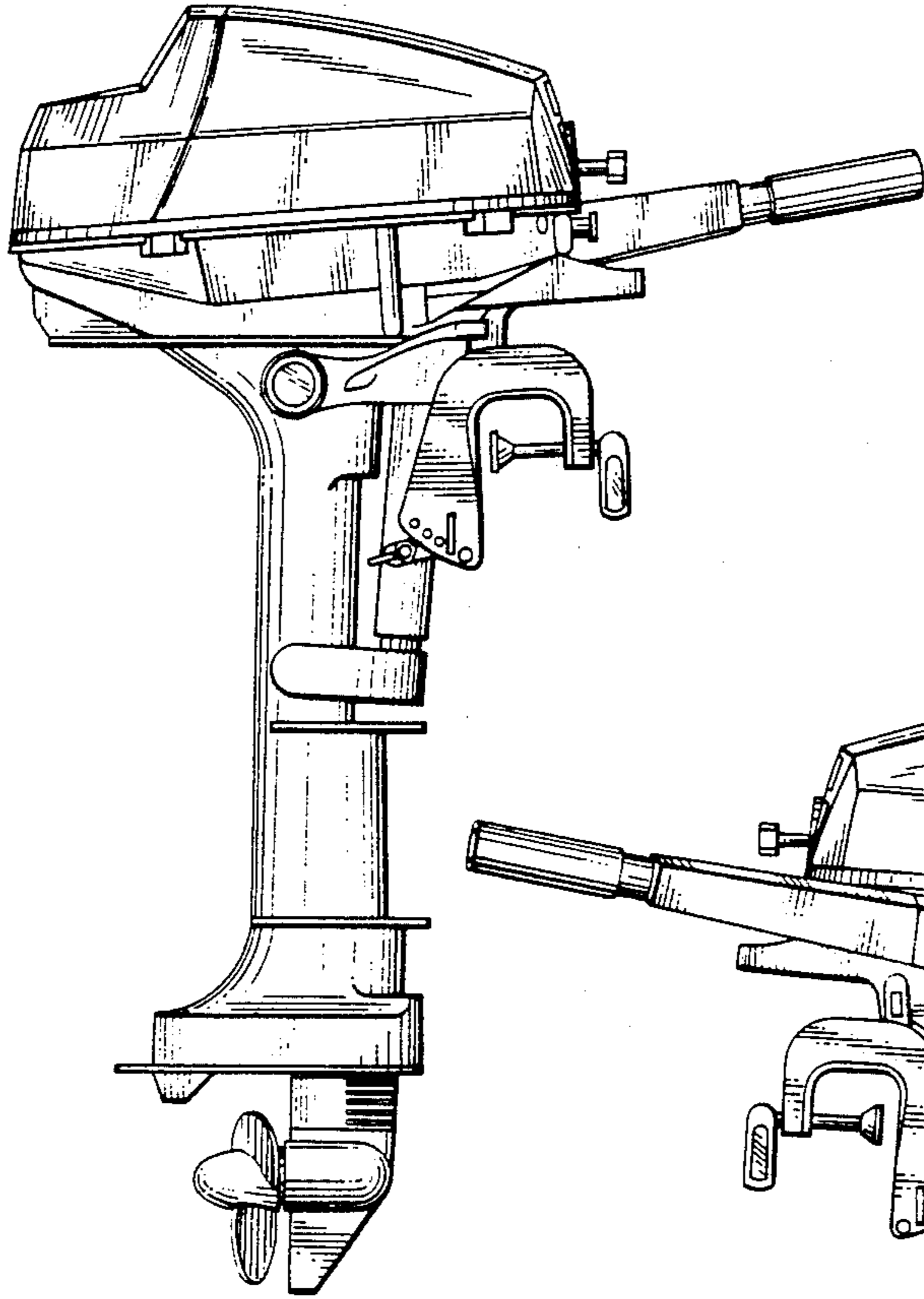

FIG. 4

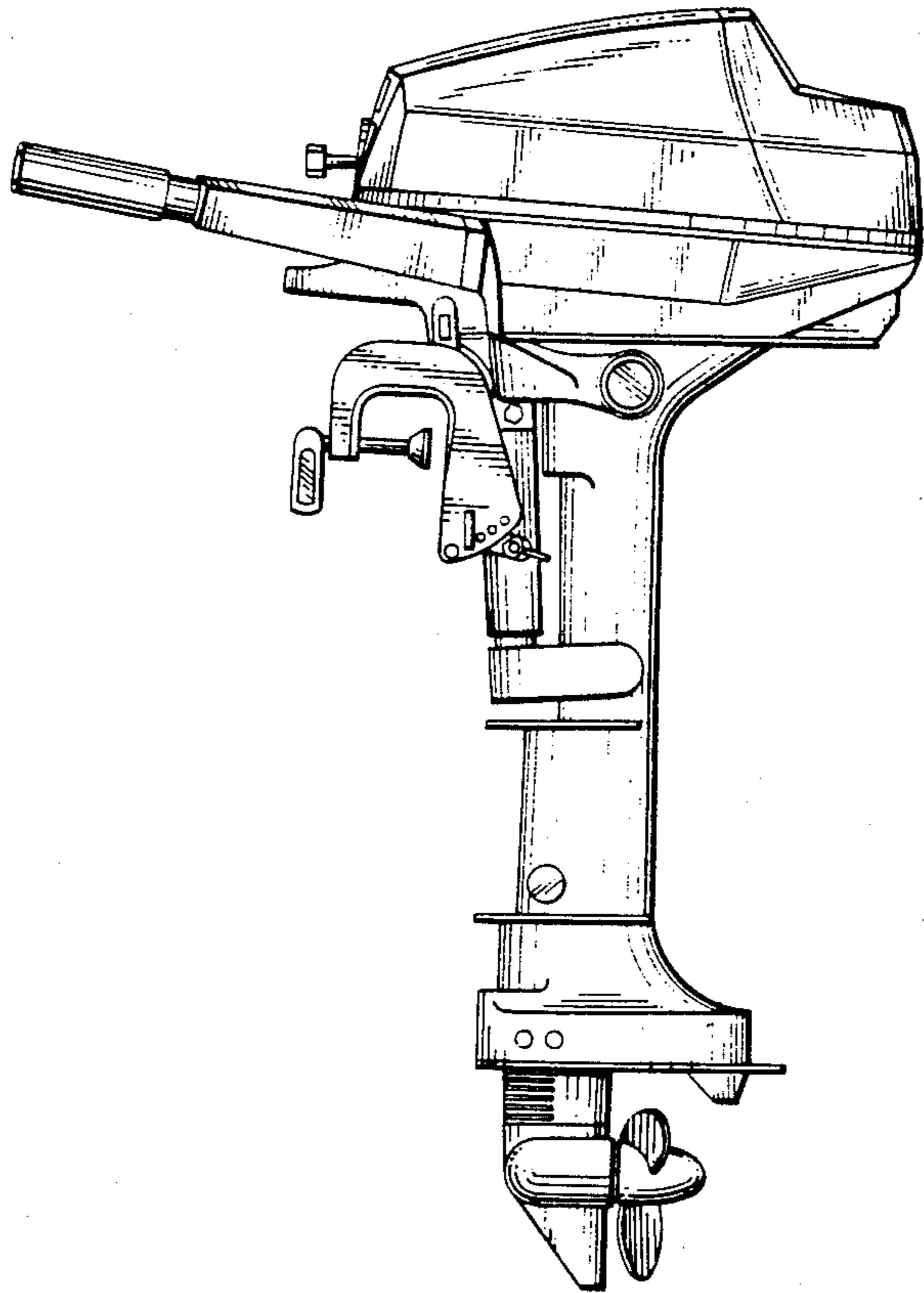

FIG. 5

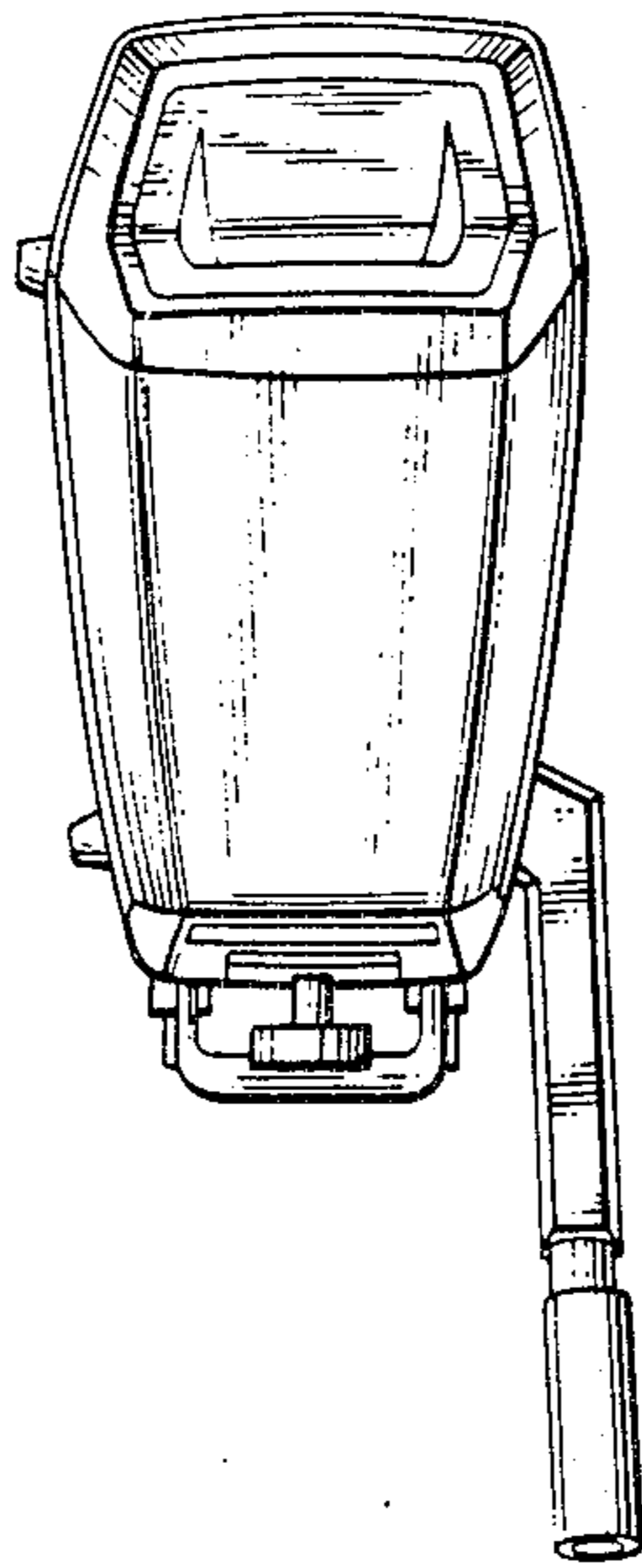

FIG. 6

