

[54] **SPARE TIRE HOLDER**

[76] **Inventor: Roy S. Bowman, R.R. 1, Box 120, Pipestone, Minn. 56164**

[\*\*] **Term: 14 Years**

[21] **Appl. No.: 681,808**

[22] **Filed: Dec. 14, 1984**

[52] **U.S. Cl. .... D12/202**

[58] **Field of Search ..... D12/202; 224/42.06, 224/42.12, 42.21, 42.24, 42.25, 42.26; 296/37.2**

[56] **References Cited**

**U.S. PATENT DOCUMENTS**

3,448,904 6/1969 Sahr ..... 224/42.21  
3,804,308 4/1974 Bodde ..... 224/42.06

**OTHER PUBLICATIONS**

J. C. Whitney Catalog No. 392B, ©1979, p. 42, Heavy

Duty Tire Carrier, top right side of page and Front Tire Carrier, center right side of page.

*Primary Examiner*—James M. Gandy  
*Attorney, Agent, or Firm*—Burd, Bartz & Gutenkauf

[57] **CLAIM**

The ornamental design for a spare tire holder, as shown and described.

**DESCRIPTION**

FIG. 1 is a perspective view of a spare tire holder of my new design;

FIG. 2 is a side elevation view thereof, the opposite side being a mirror image of that shown;

FIG. 3 is a front elevation view thereof;

FIG. 4 is a rear elevation view thereof;

FIG. 5 is a top plan view thereof; and

FIG. 6 is a bottom plan view thereof.

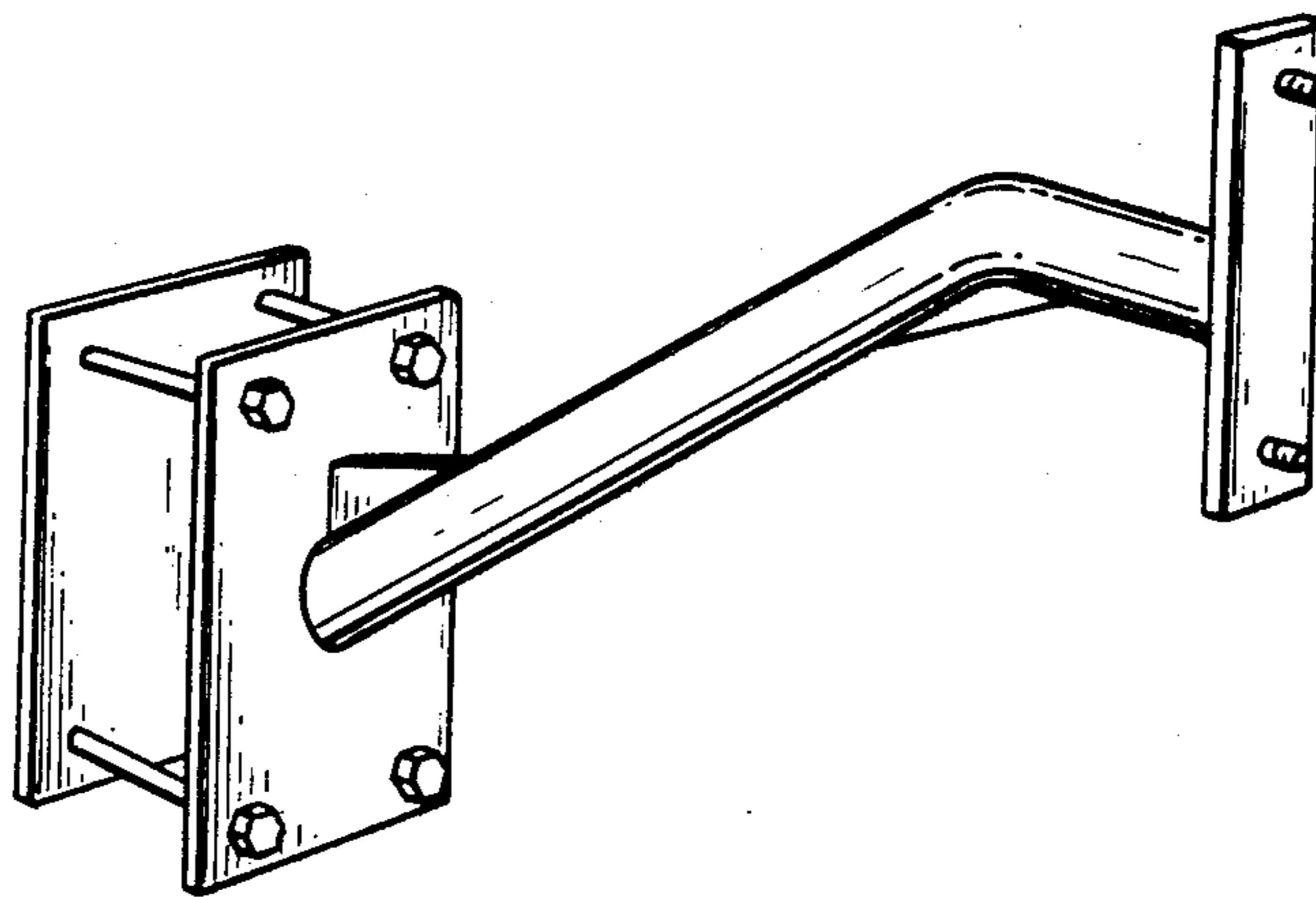

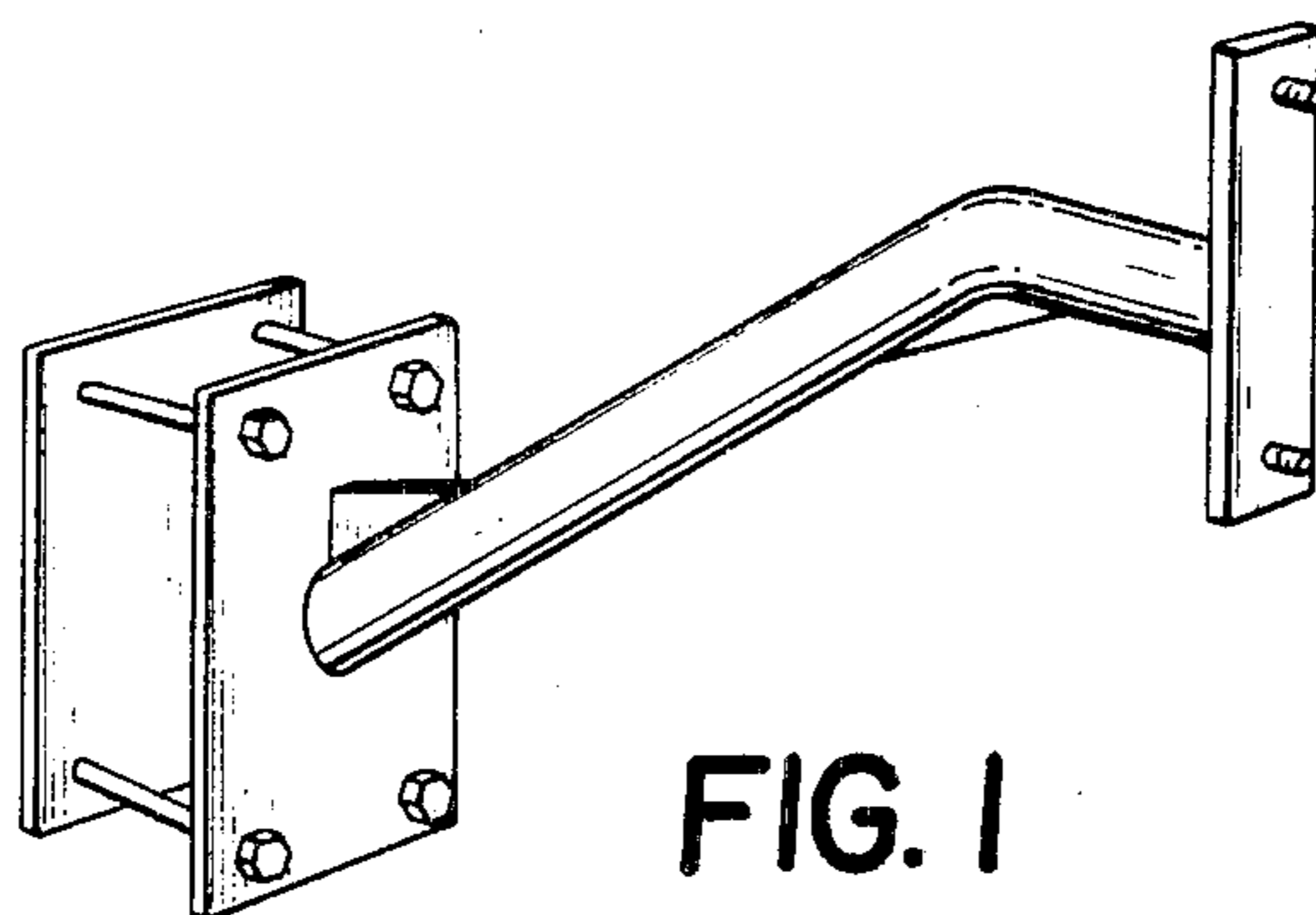

FIG. 1

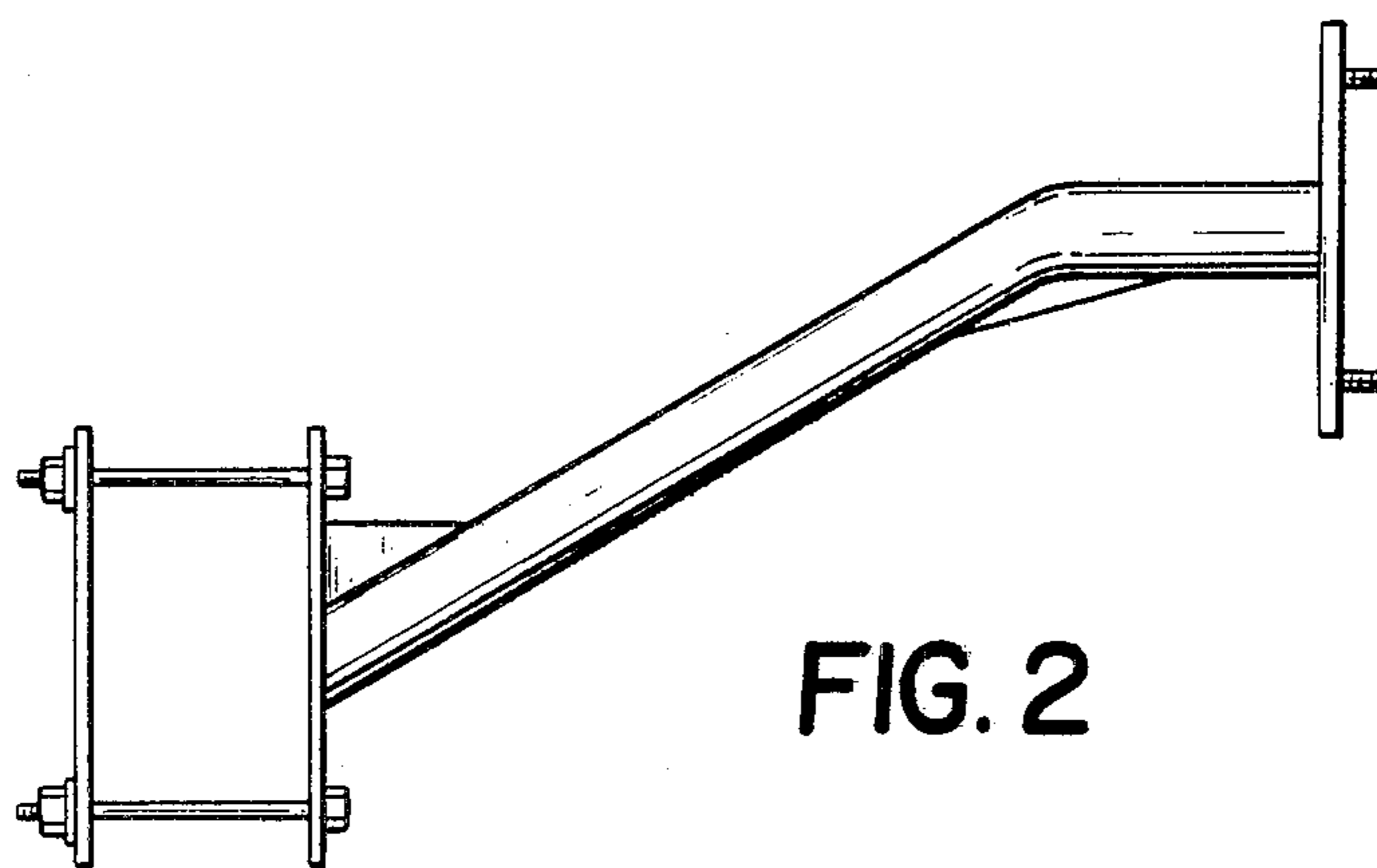

FIG. 2

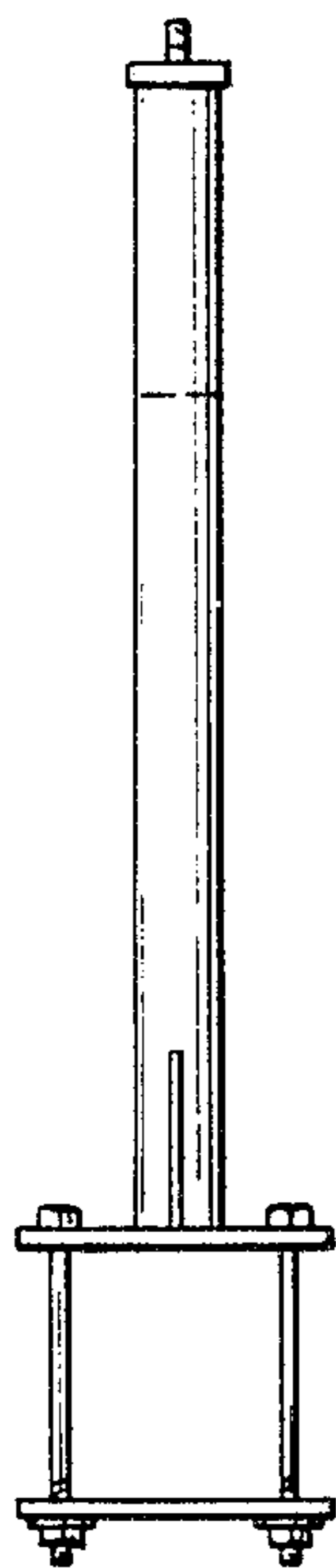

FIG. 5

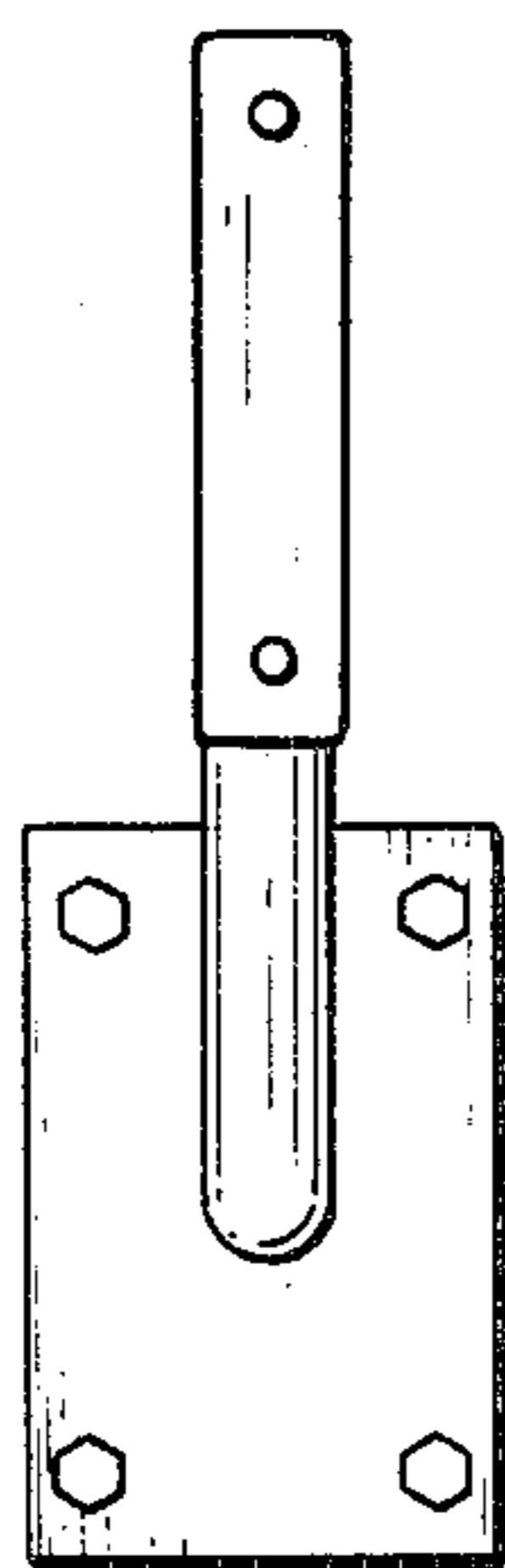

FIG. 3

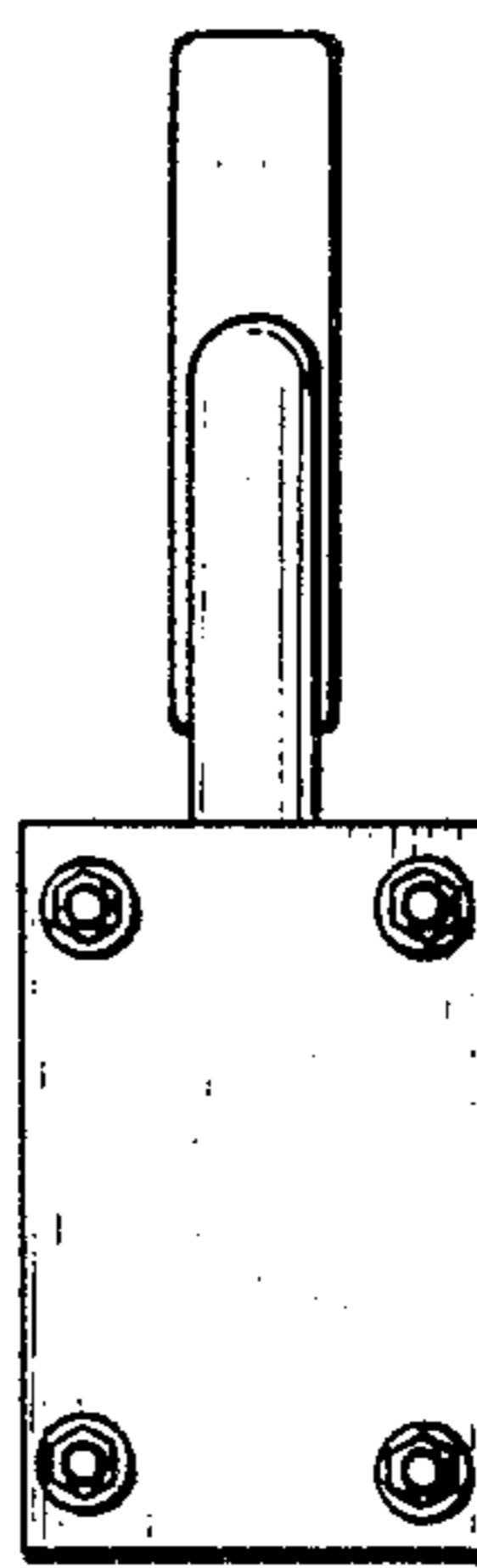

FIG. 4

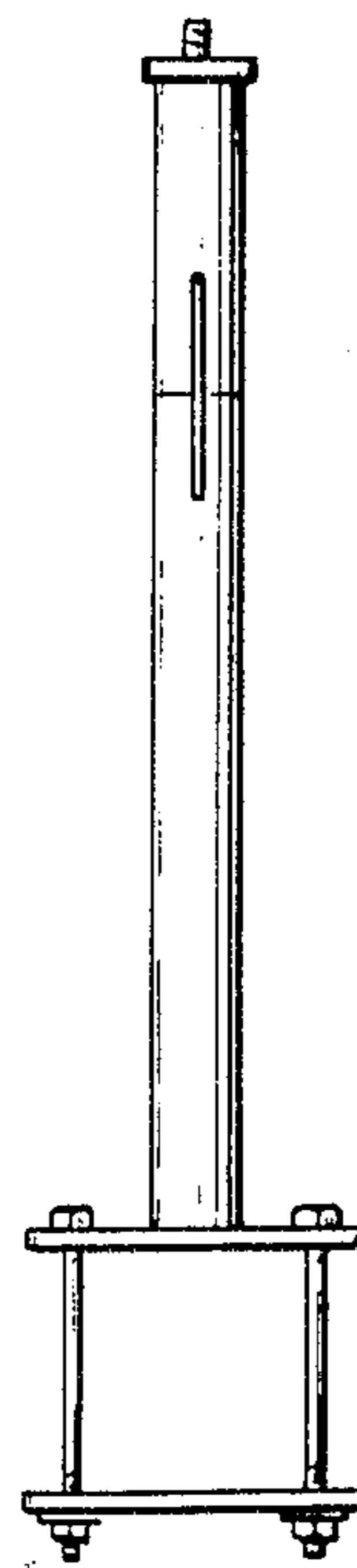

FIG. 6