

United States Patent [19]

Tomkin et al.

[11] Patent Number: **Des. 288,968**

[45] Date of Patent: **** Mar. 24, 1987**

[54] **AUTOMOBILE BRAKE LIGHT**

[75] Inventors: **Douglas Tomkin, Happy Valley;**
Mica Pavlovic, Shatin, both of Hong
Kong

[73] Assignee: **Redondo Investment Limited,**
Monrovia, Liberia

[**] Term: **14 Years**

[21] Appl. No.: **703,773**

[22] Filed: **Feb. 21, 1985**

[52] U.S. Cl. **D26/28**

[58] Field of Search **D26/28-36;**
362/61, 80, 83, 397; 340/87

[56] **References Cited**

U.S. PATENT DOCUMENTS

D. 230,626 3/1974 Heenan et al. **D26/28**
D. 231,120 4/1974 Shanok et al. **D26/28**
D. 269,464 6/1983 Caroli **D26/28**

D. 274,269 6/1984 Shanklin **D26/28**
D. 274,371 6/1984 Shanklin **D26/28**
4,463,411 7/1984 Proctor **362/61**
4,575,782 3/1986 Levine et al. **340/87 X**

Primary Examiner—Susan J. Lucas
Attorney, Agent, or Firm—David H. Semmes; Warren E.
Olsen

[57] **CLAIM**

The ornamental design for an automobile brake light, as shown and described.

DESCRIPTION

FIG. 1 is a top front perspective view of an automobile brake light showing our new design;
FIG. 2 is a front elevational view thereof;
FIG. 3 is a bottom plan view thereof;
FIG. 4 is a rear elevational view thereof;
FIG. 5 is a top plan view thereof;
FIG. 6 is a right-hand side elevational view thereof;
FIG. 7 is a left-hand side elevational view thereof.

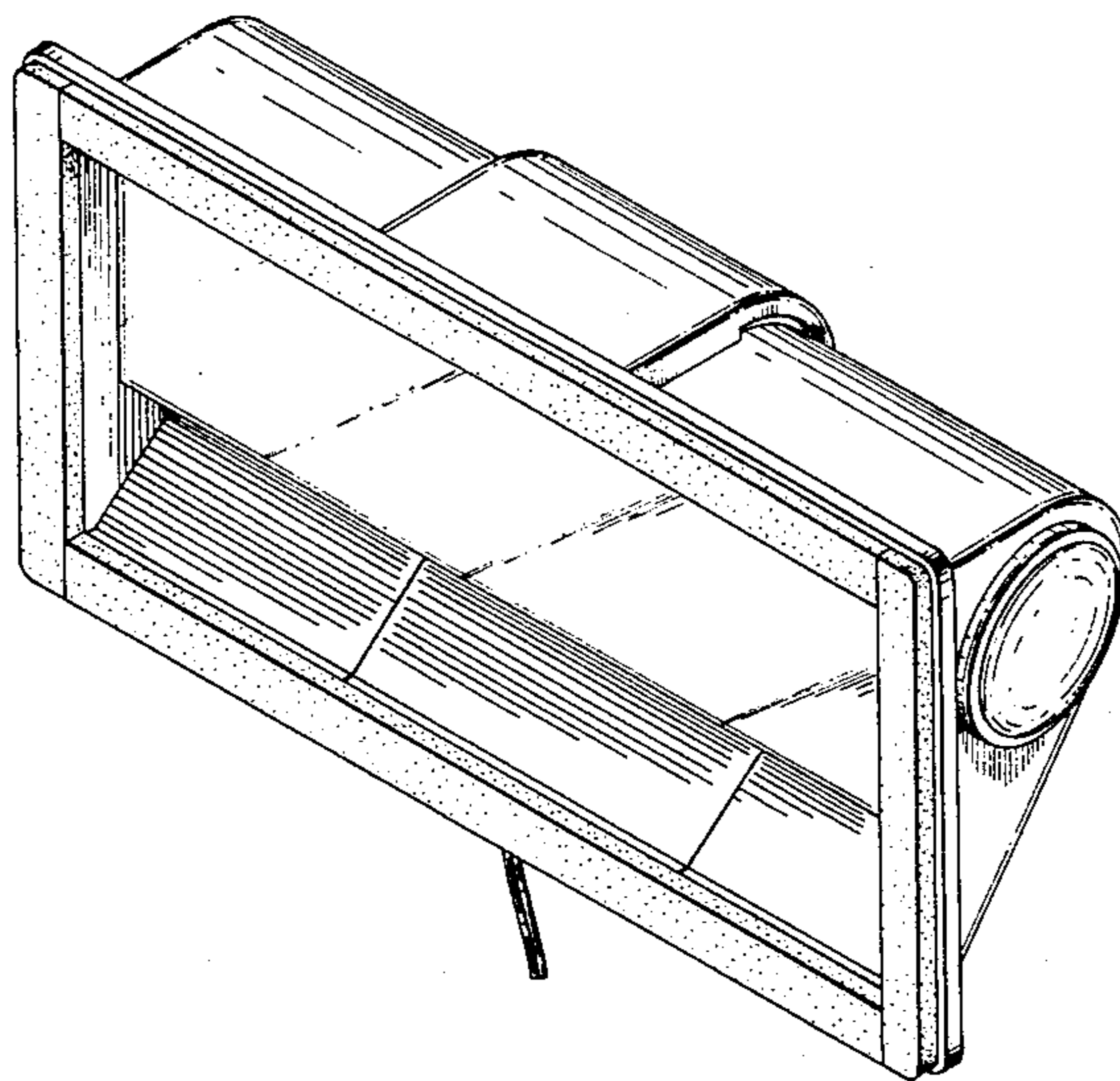

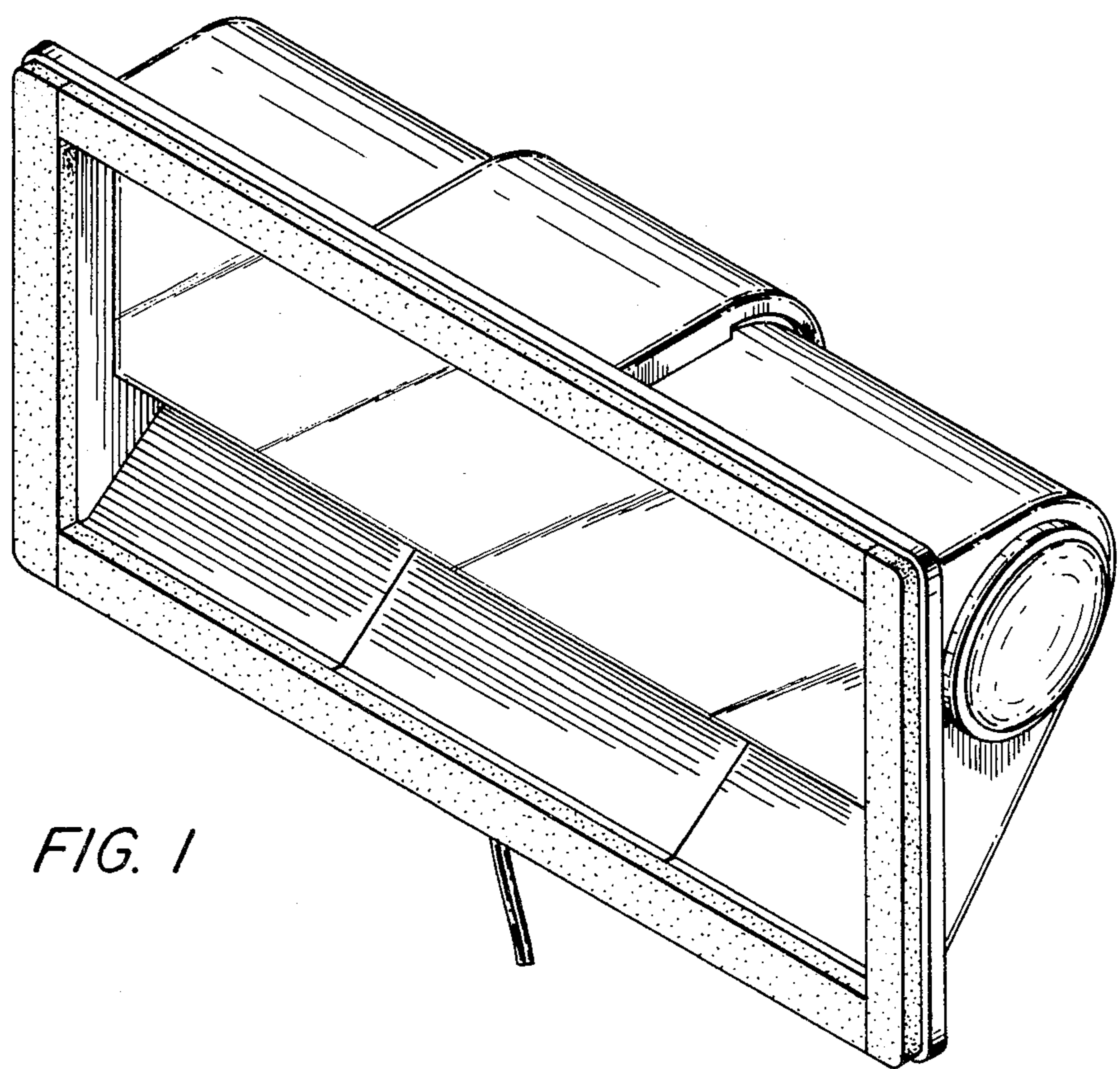

FIG. 1

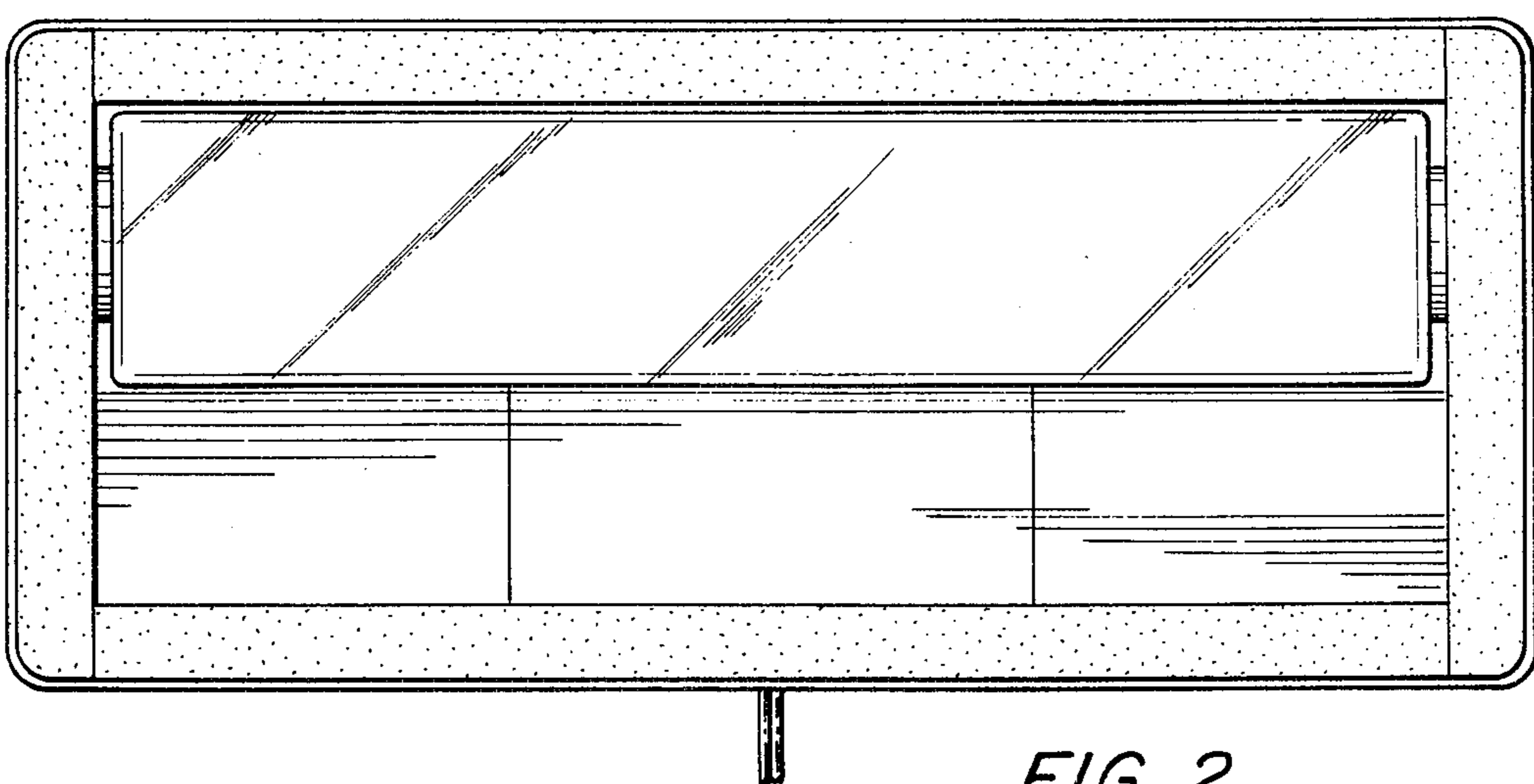

FIG. 2

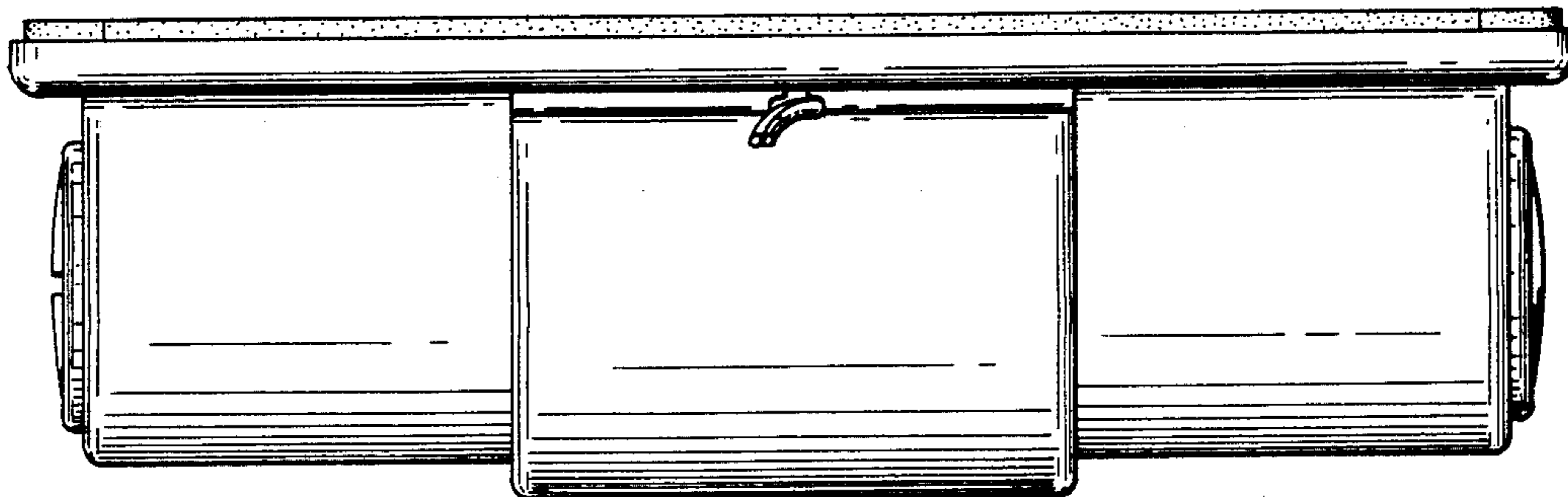

FIG. 3

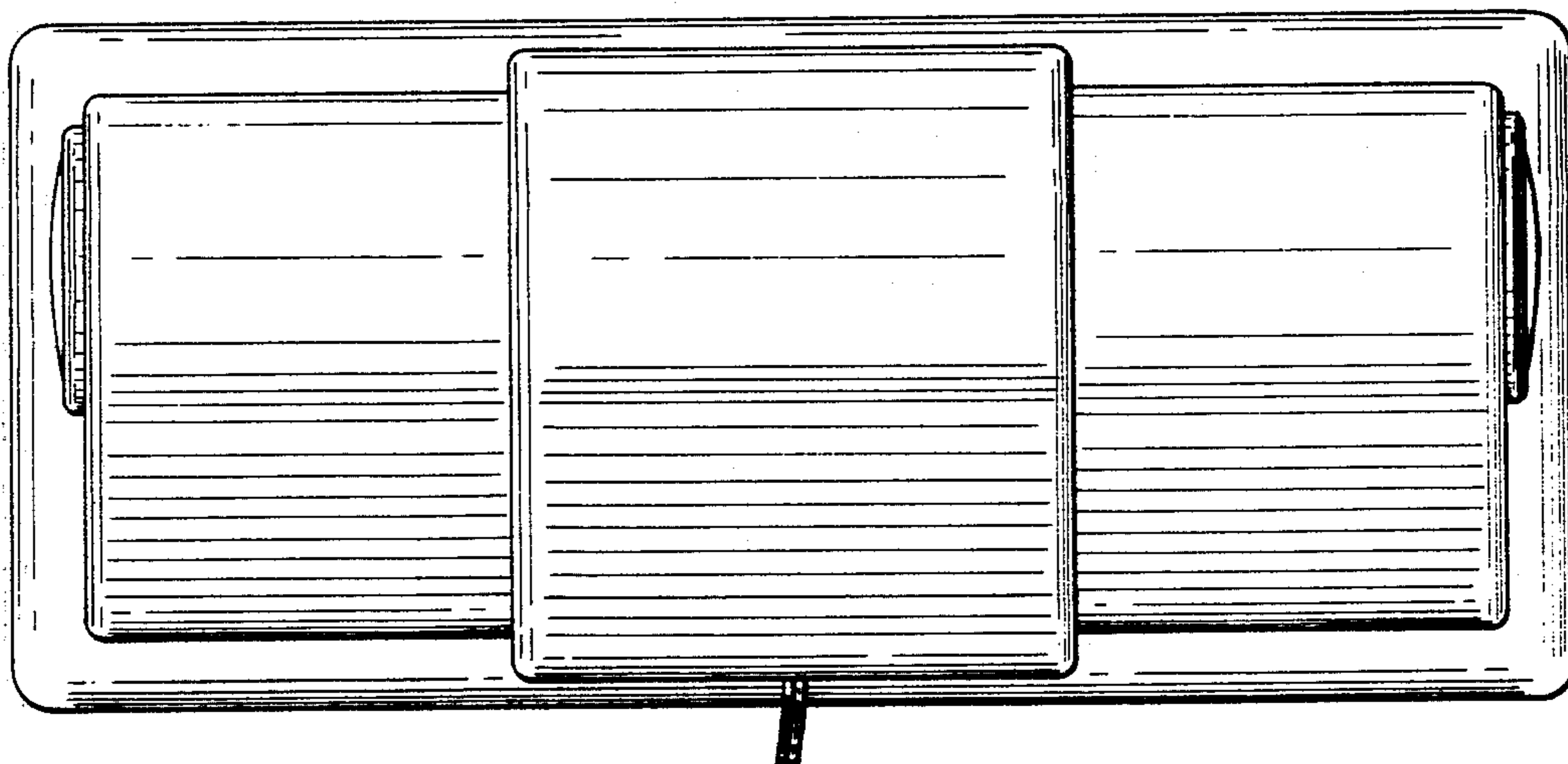

FIG. 4

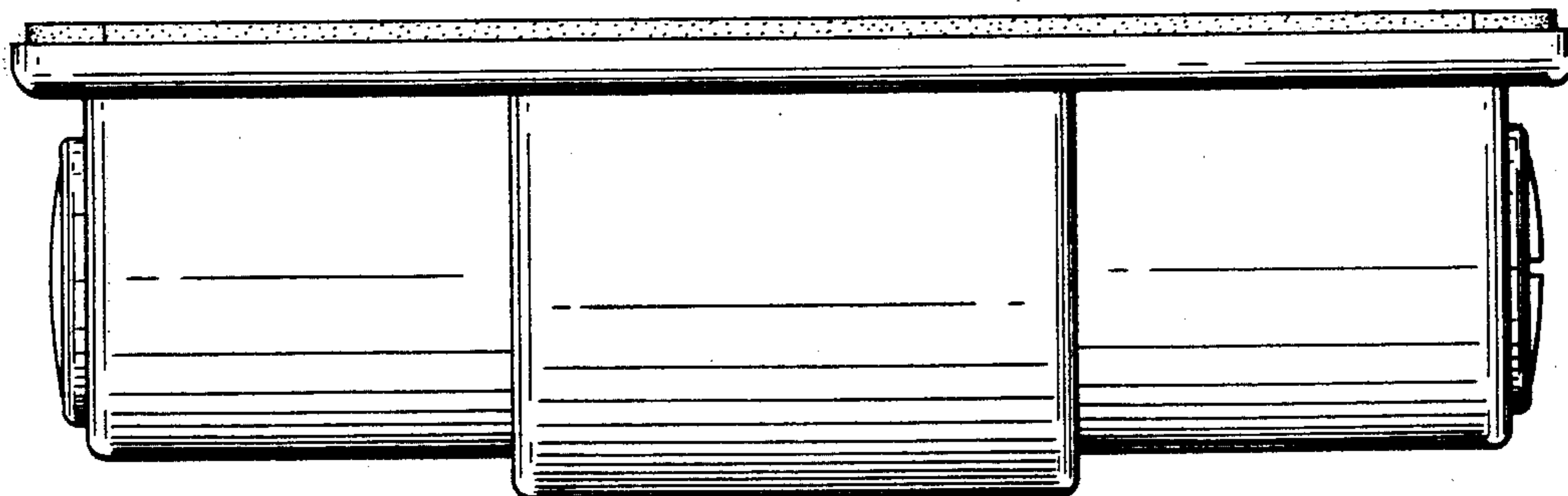

FIG. 5

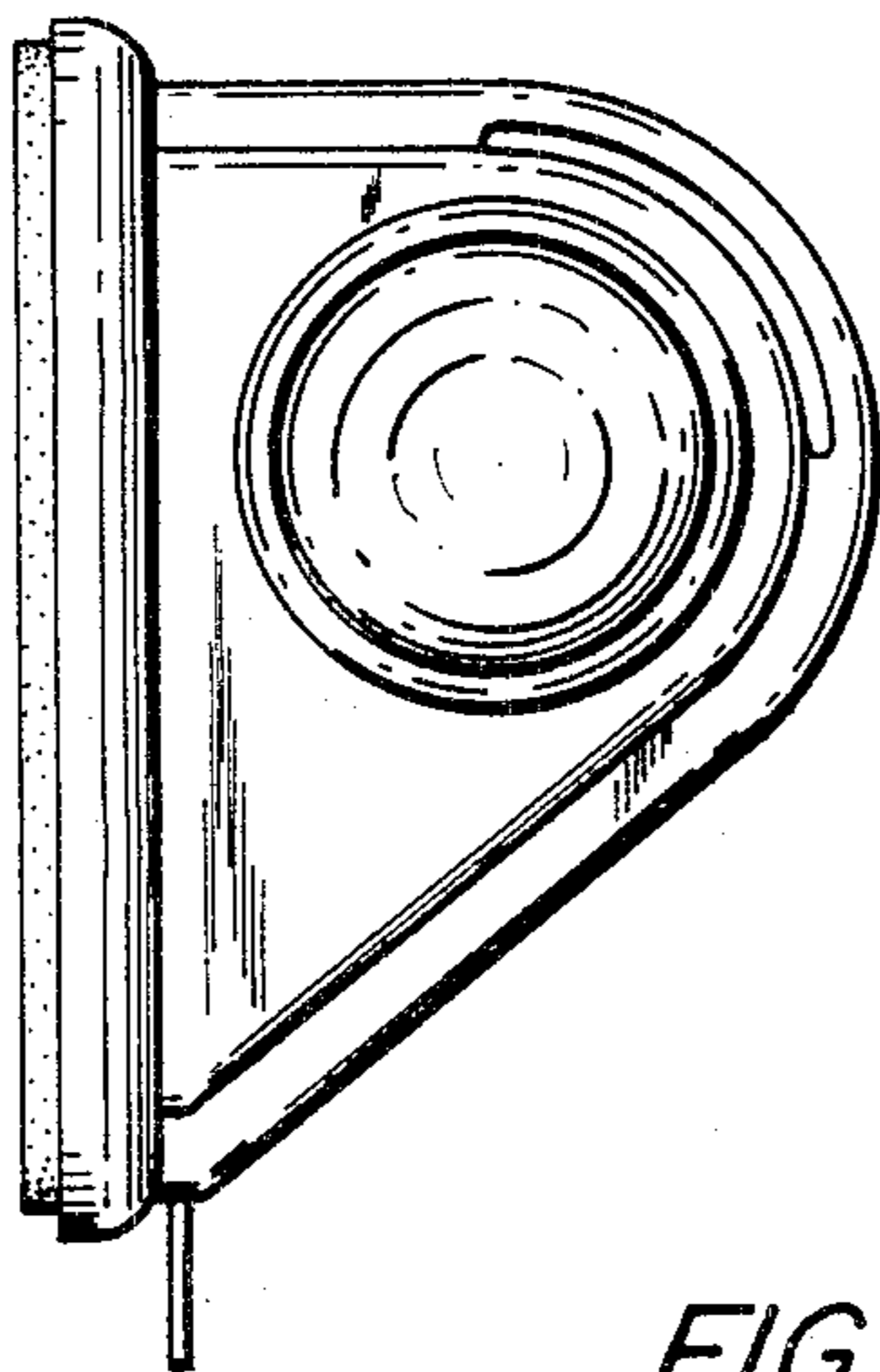

FIG. 6

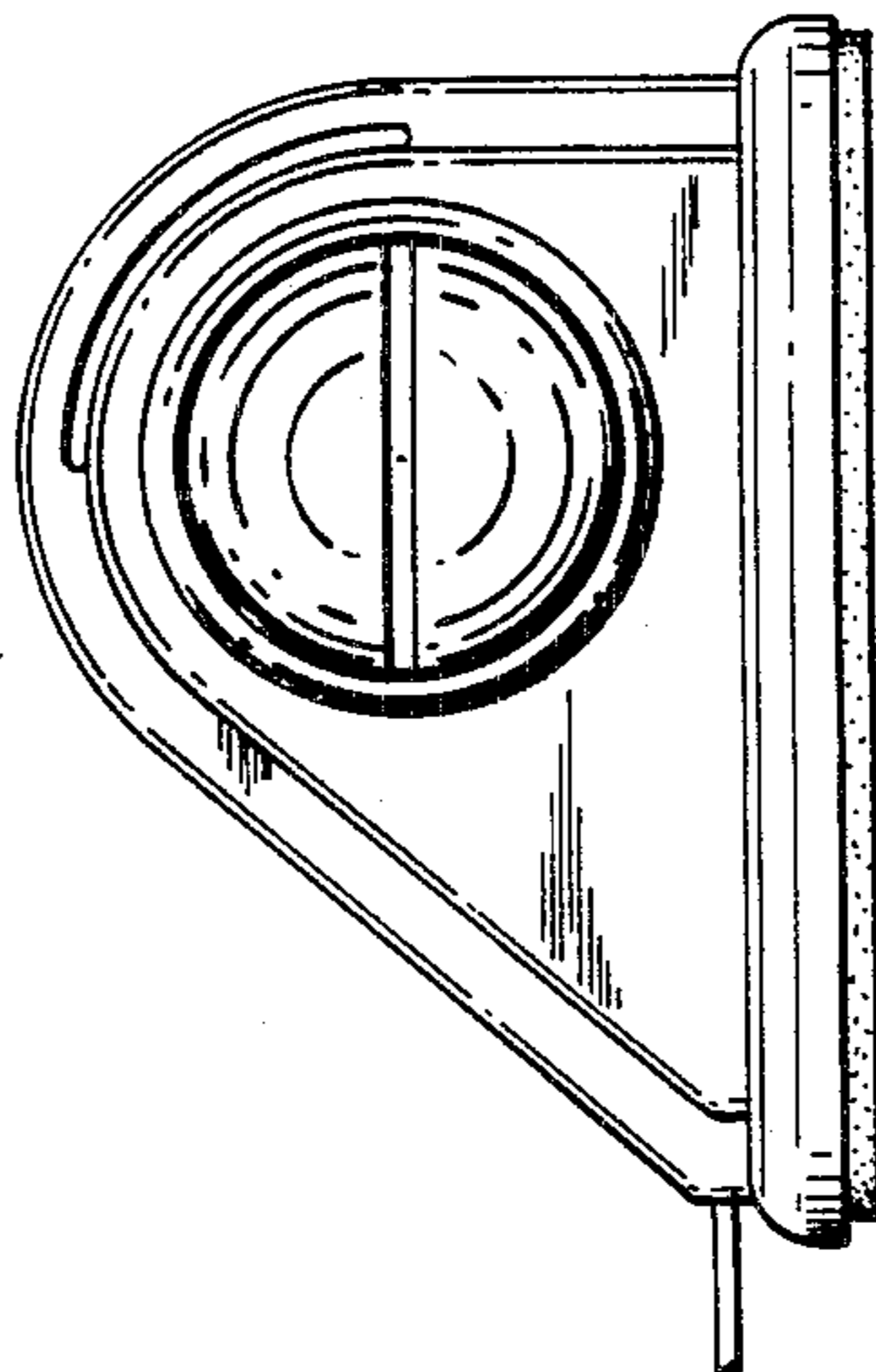

FIG. 7