

[54] LIGHT SENSITIVE NIGHT LIGHT

[75] Inventor: Stuart Naft, Easton, Md.

[73] Assignee: Black & Decker Inc., Newark, Del.

[**] Term: 14 Years

[21] Appl. No.: 581,623

[22] Filed: Feb. 21, 1984

[52] U.S. Cl. D26/26

[58] Field of Search D26/26; 362/226

[56] References Cited

U.S. PATENT DOCUMENTS

D. 274,369 6/1984 Schwartz D26/26

4,343,032 8/1982 Schwartz 362/226 X

Primary Examiner—Susan J. Lucas

Attorney, Agent, or Firm—Paul J. Lerner

[57] CLAIM

The ornamental design for a light sensitive night light, as shown and described.

DESCRIPTION

FIG. 1 is a top, front and right side perspective view of a light sensitive night light showing my new design;

FIG. 2 is a right side elevational view thereof on an enlarged scale, the left side being identical;

FIG. 3 is a front elevational view thereof on an enlarged scale;

FIG. 4 is a rear elevational view thereof on an enlarged scale;

FIG. 5 is a top plan view thereof on an enlarged scale;

FIG. 6 is a bottom plan view thereof on an enlarged scale;

FIG. 7 is a cross sectional view thereof taken along line 7—7 of FIG. 2.

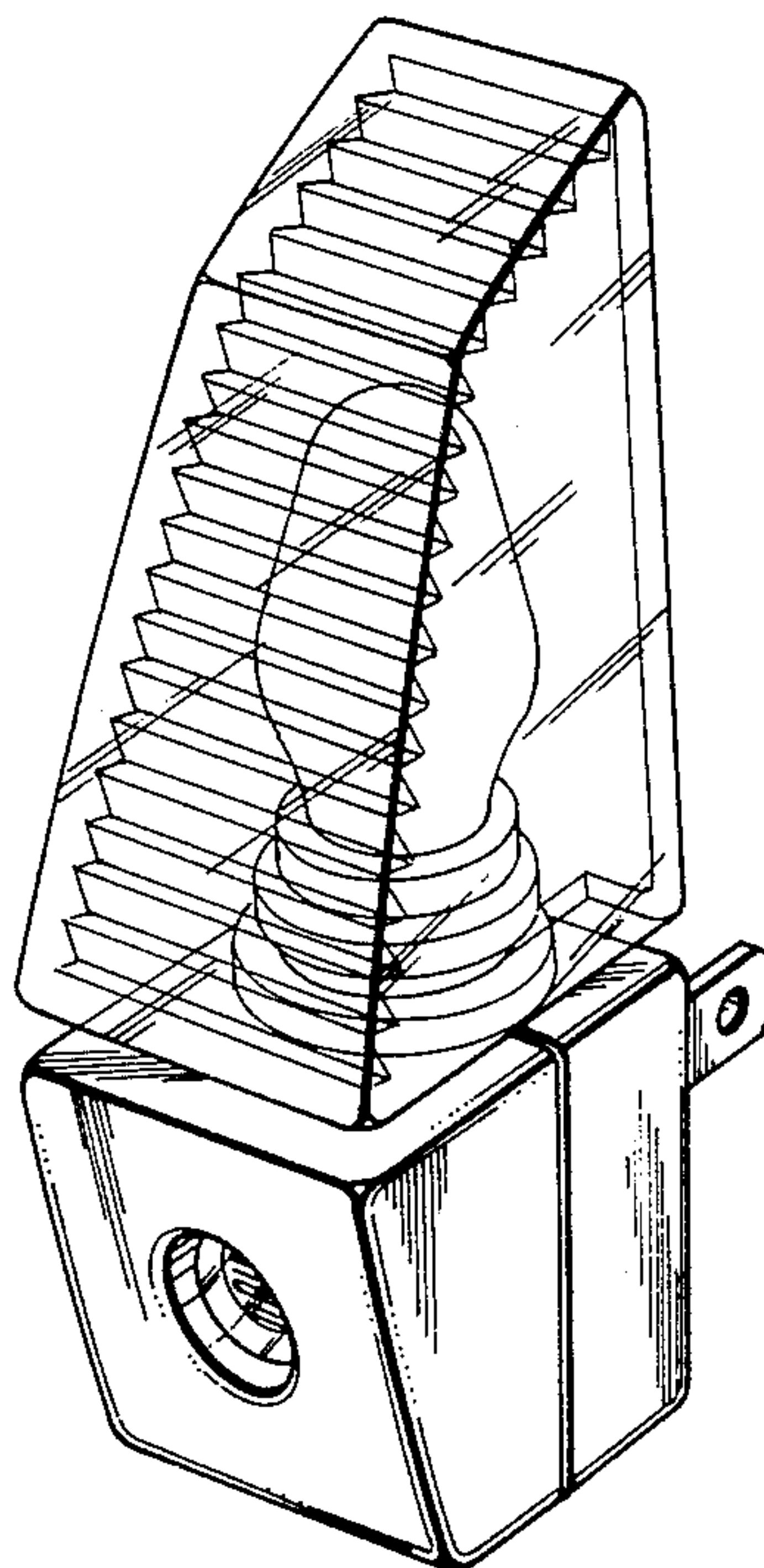

FIG. 1.

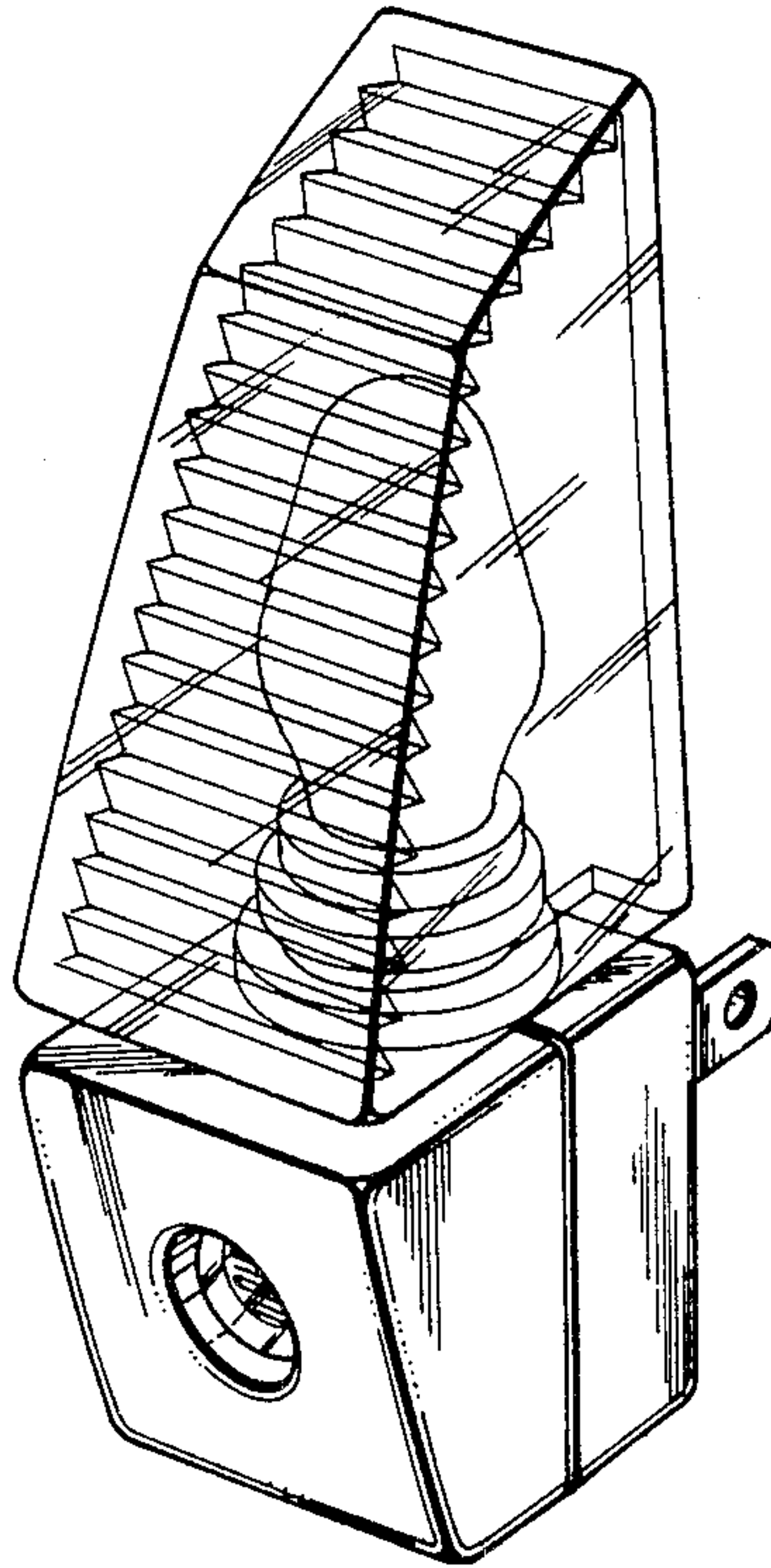

FIG. 2.

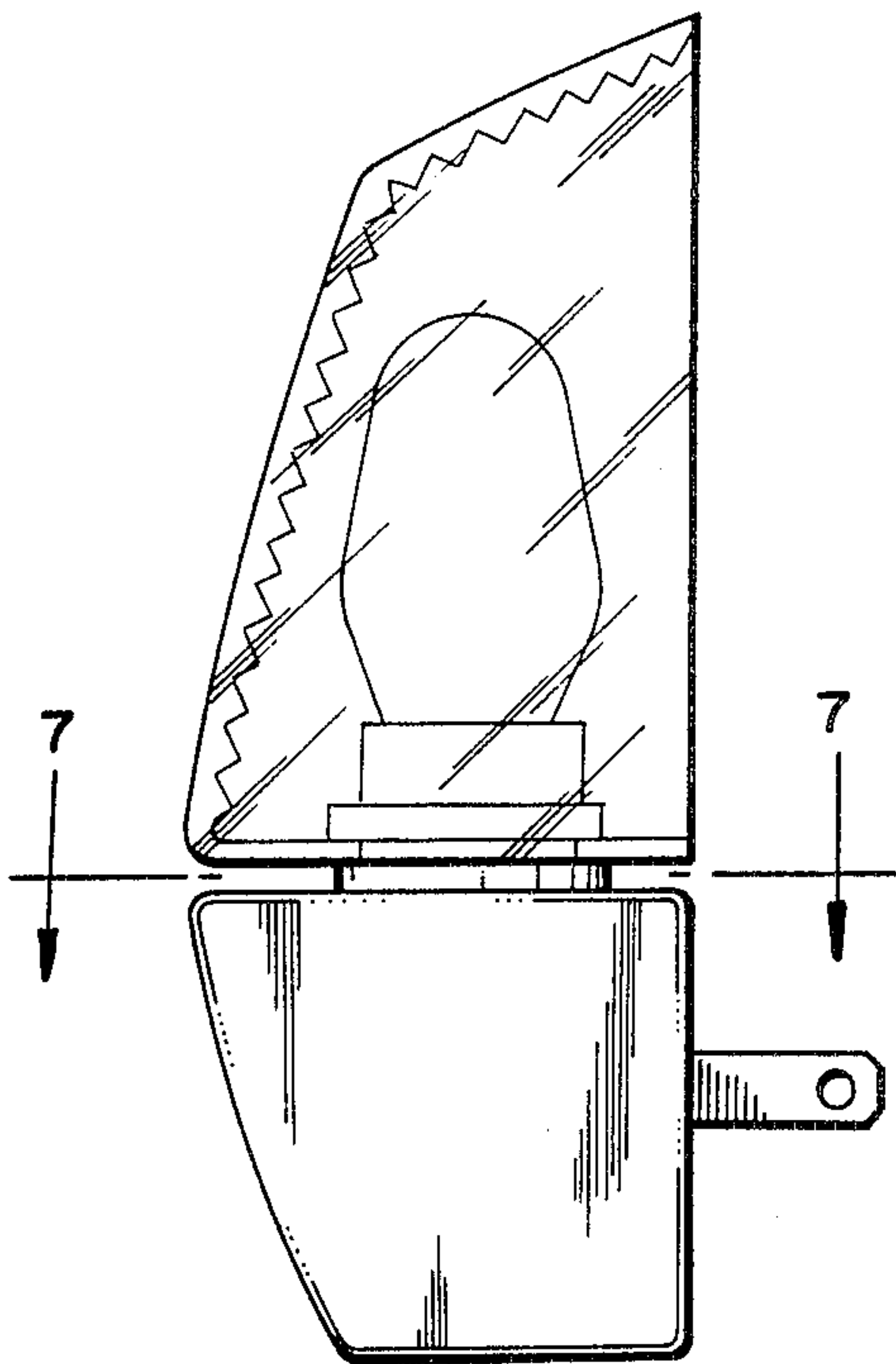

FIG. 3.

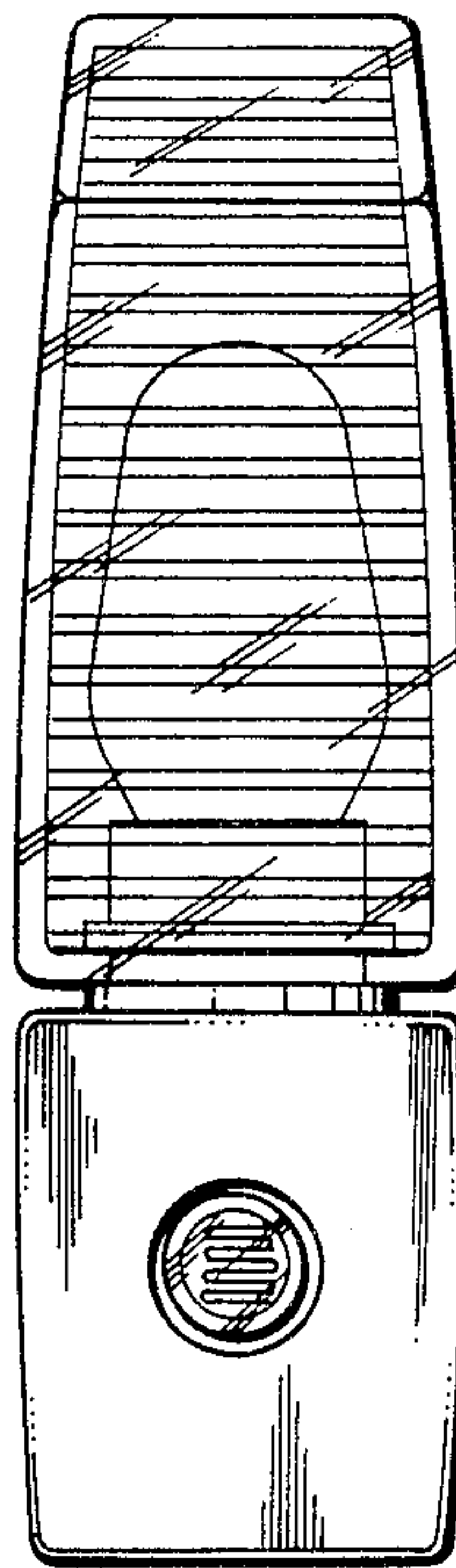

FIG. 4.

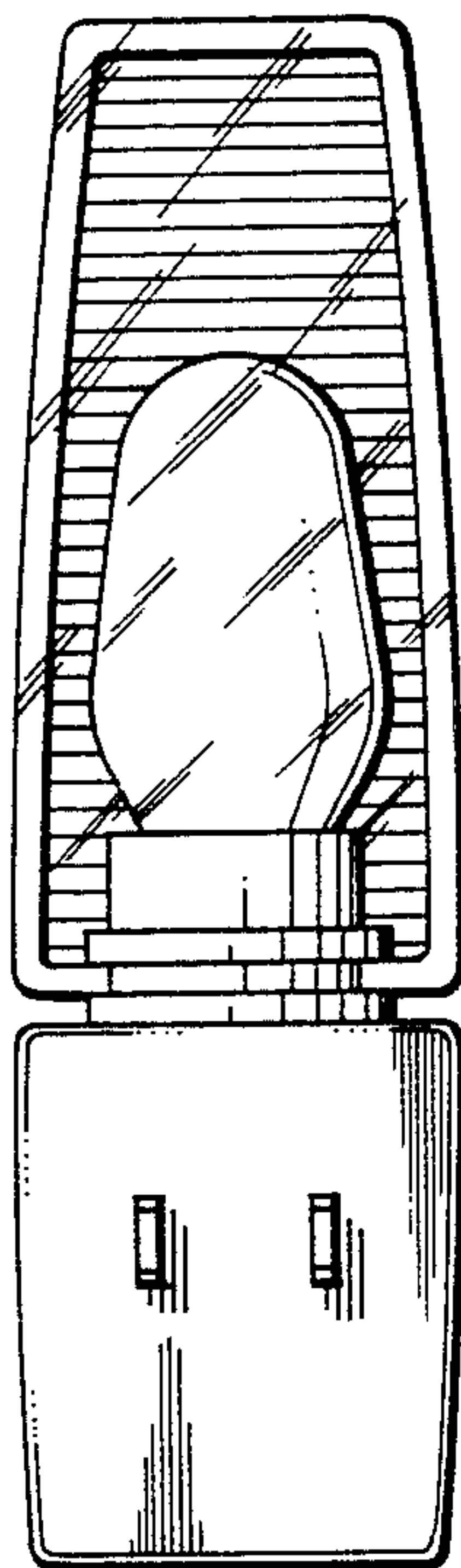

FIG. 5.

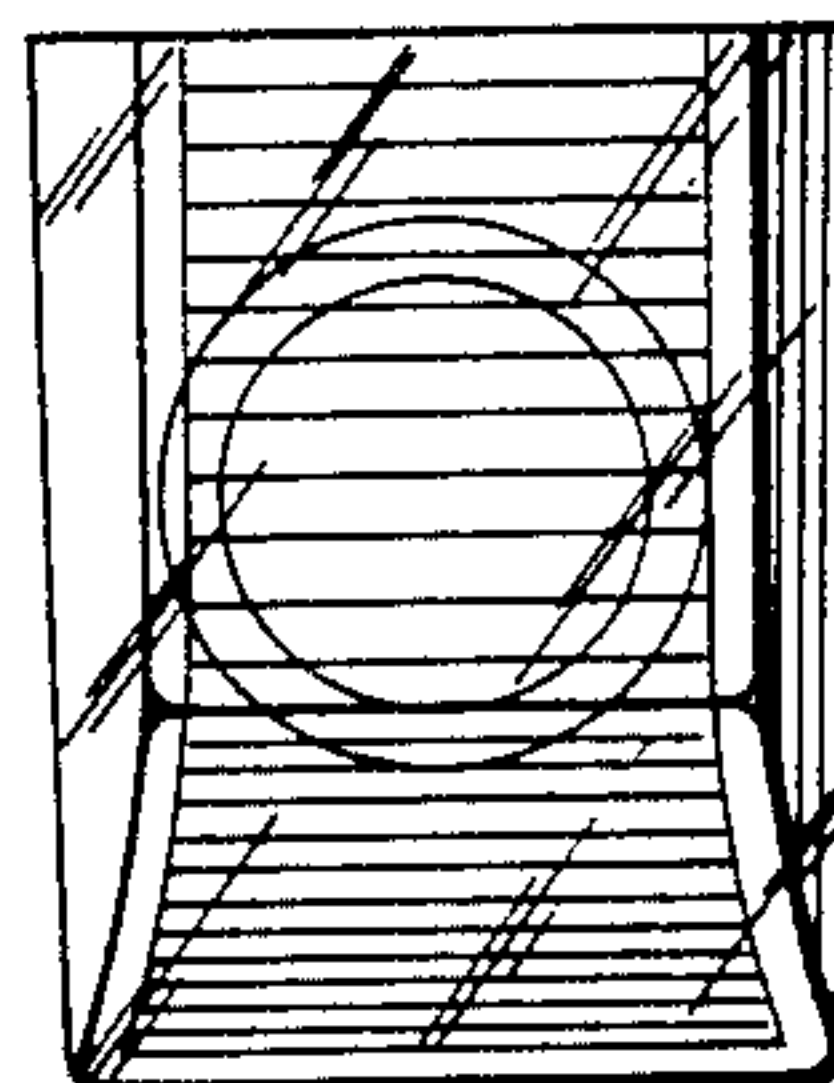

FIG. 7.

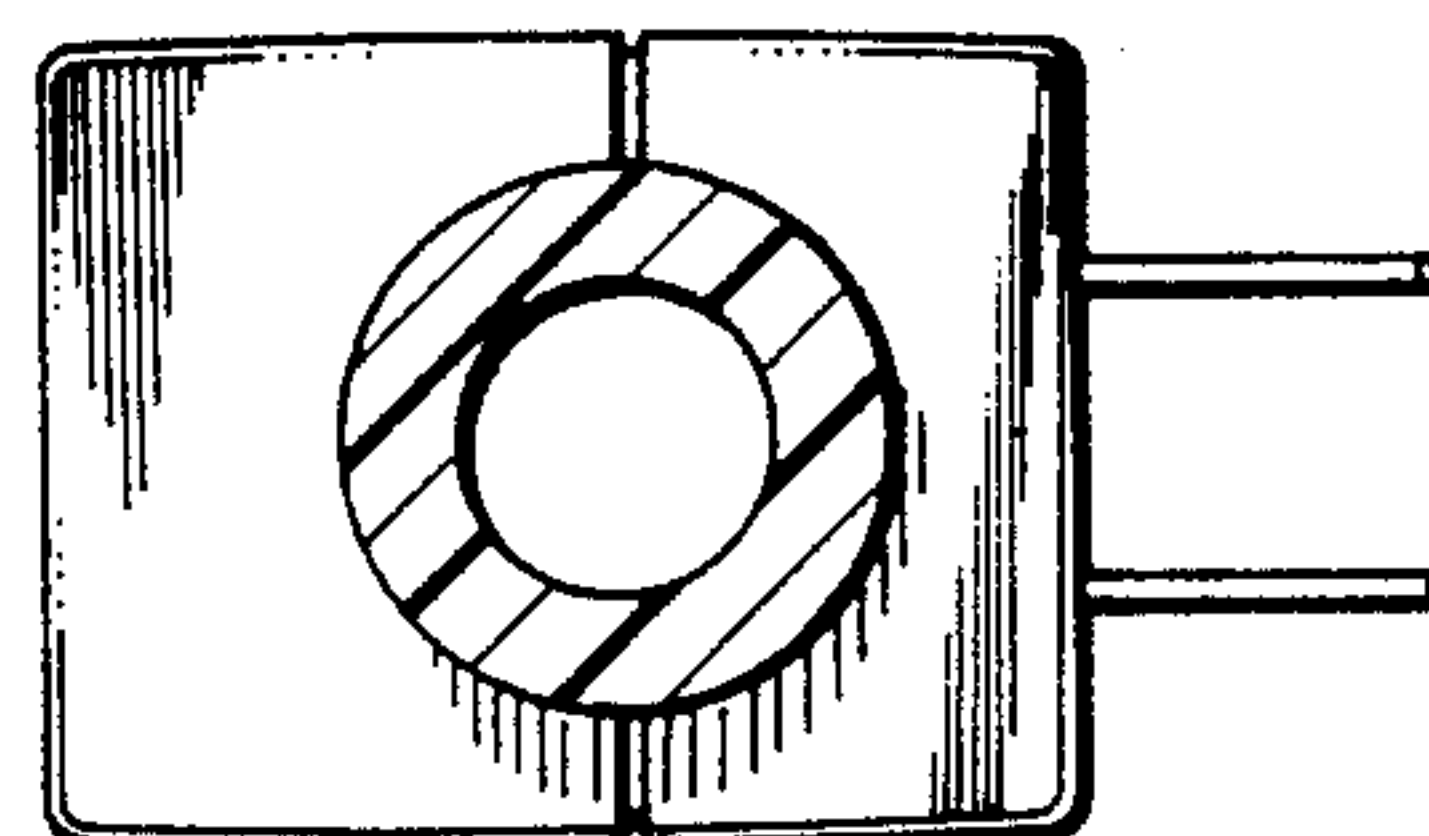

FIG. 6.

