

[54] INDUSTRIAL ROBOT

[75] Inventors: Atuyuki Gotou, Mitaka; Masato Shibayama, Sayama; Takeshi Abe, Tokyo; Takashi Kawakami, Shimizu; Shintaro Masuda, Hujieda, all of Japan

[73] Assignee: Hitachi, Ltd., Tokyo, Japan

[\*\*] Term: 14 Years

[21] Appl. No.: 583,406

[22] Filed: Feb. 24, 1984

[30] Foreign Application Priority Data

Aug. 26, 1983 [JP] Japan ..... 58-36982

[52] U.S. Cl. .... D15/199

[58] Field of Search ..... D15/122, 199; 901/14, 901/16, 18, 30, 42; 414/728, 729, 732, 738, 749

[56] References Cited

U.S. PATENT DOCUMENTS

3,901,392 8/1975 Streckert ..... 901/16

4,005,782	2/1977	Crockett	.....	901/16
4,274,801	6/1981	Herb et al.	.....	414/749
4,317,560	3/1982	Troyer	.....	901/42
4,557,657	12/1985	Olson et al.	.....	901/14

Primary Examiner—B. J. Bullock  
Attorney, Agent, or Firm—Antonelli, Terry & Wands

[57] CLAIM

The ornamental design for a industrial robot, as shown and described.

DESCRIPTION

FIG. 1 is a front, top and right side perspective view of an industrial robot showing our new design; FIG. 2 is a front elevational view thereof; FIG. 3 is a top plan view thereof; FIG. 4 is a bottom plan view thereof; FIG. 5 is a left side elevational view thereof; FIG. 6 is a right side elevational view thereof; FIG. 7 is a rear elevational view thereof; and FIG. 8 is a front, top and right side perspective view thereof, the pipes and connector brackets being shown in broken lines for illustrative purposes only.

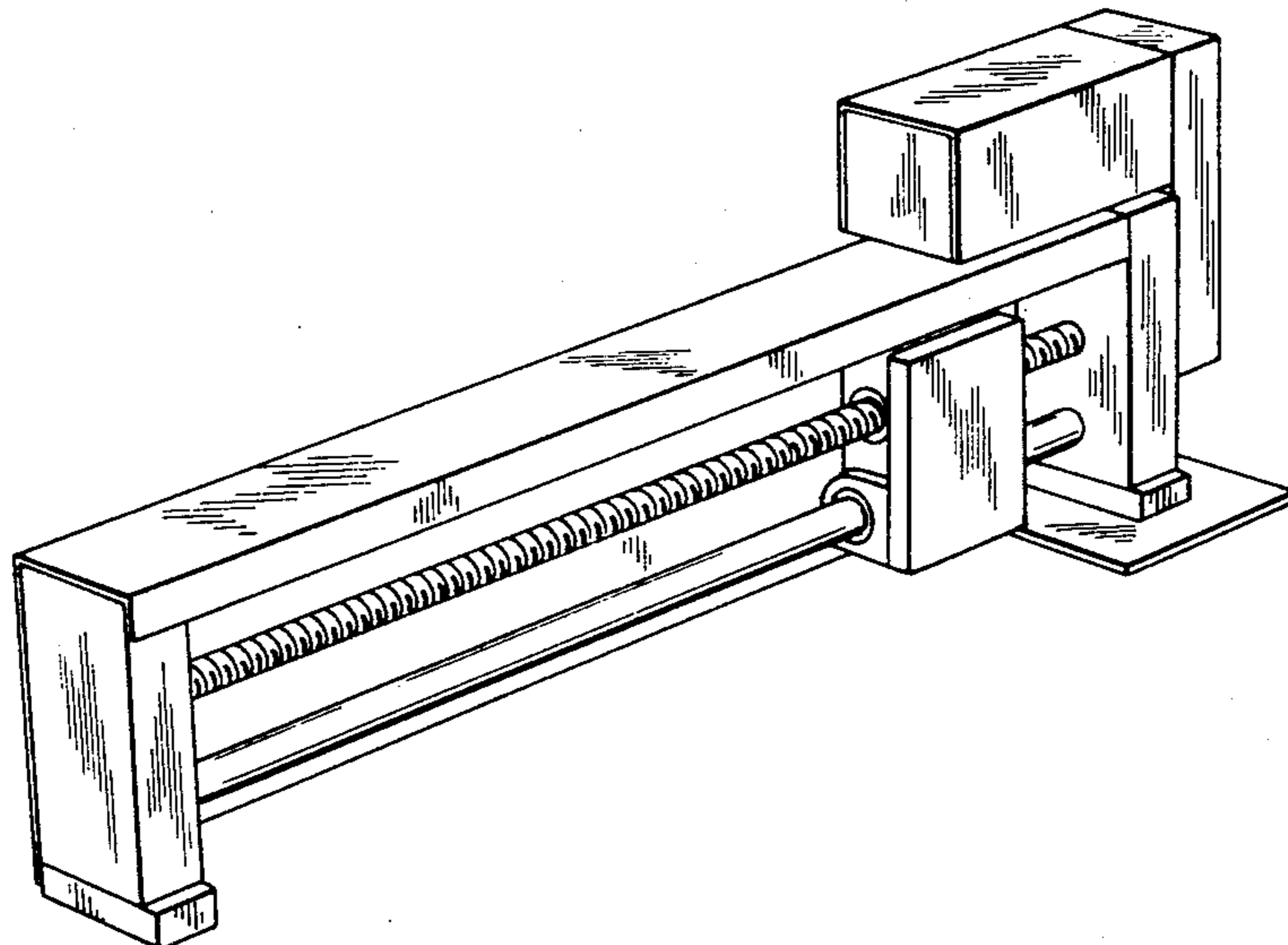
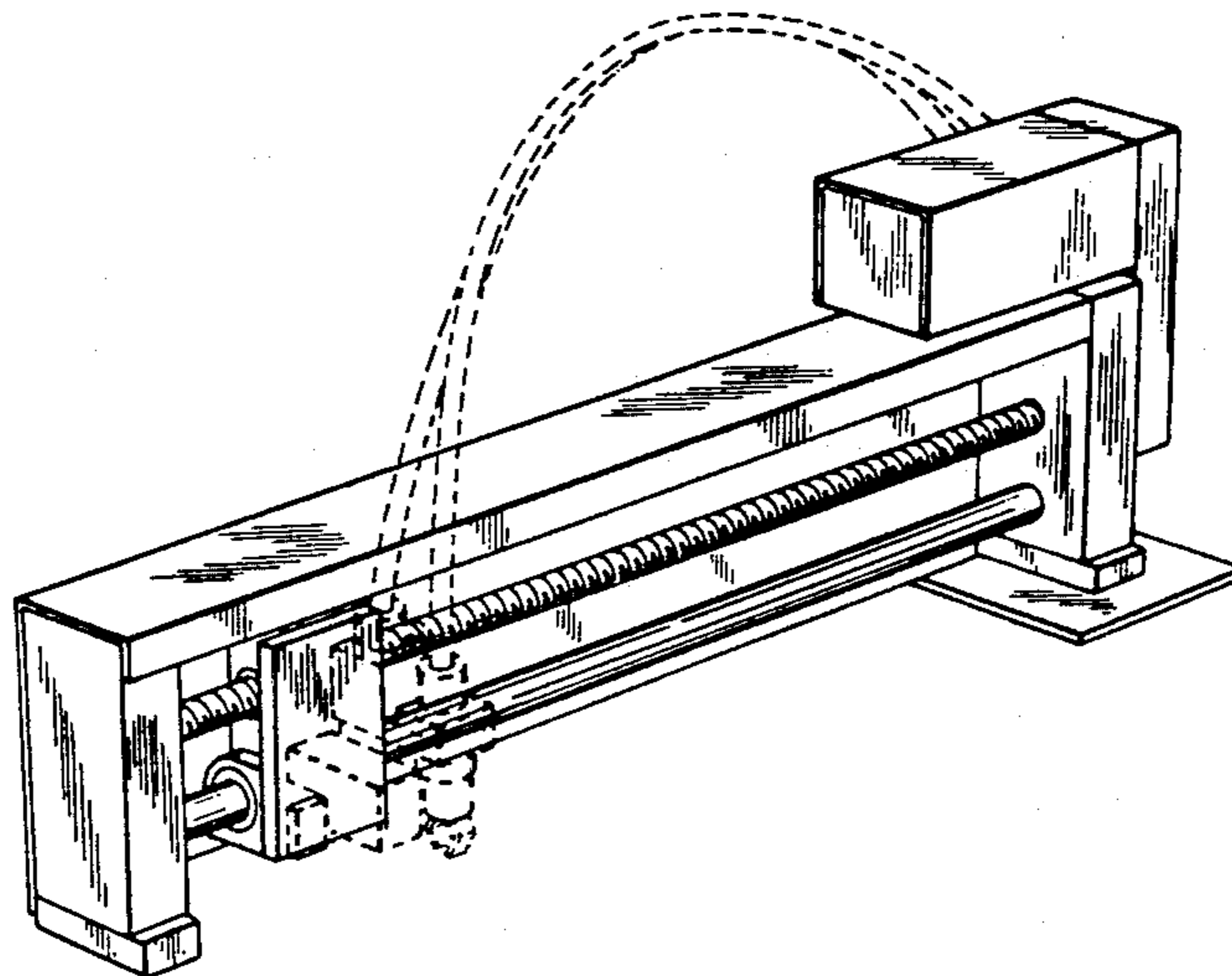

FIG. 1

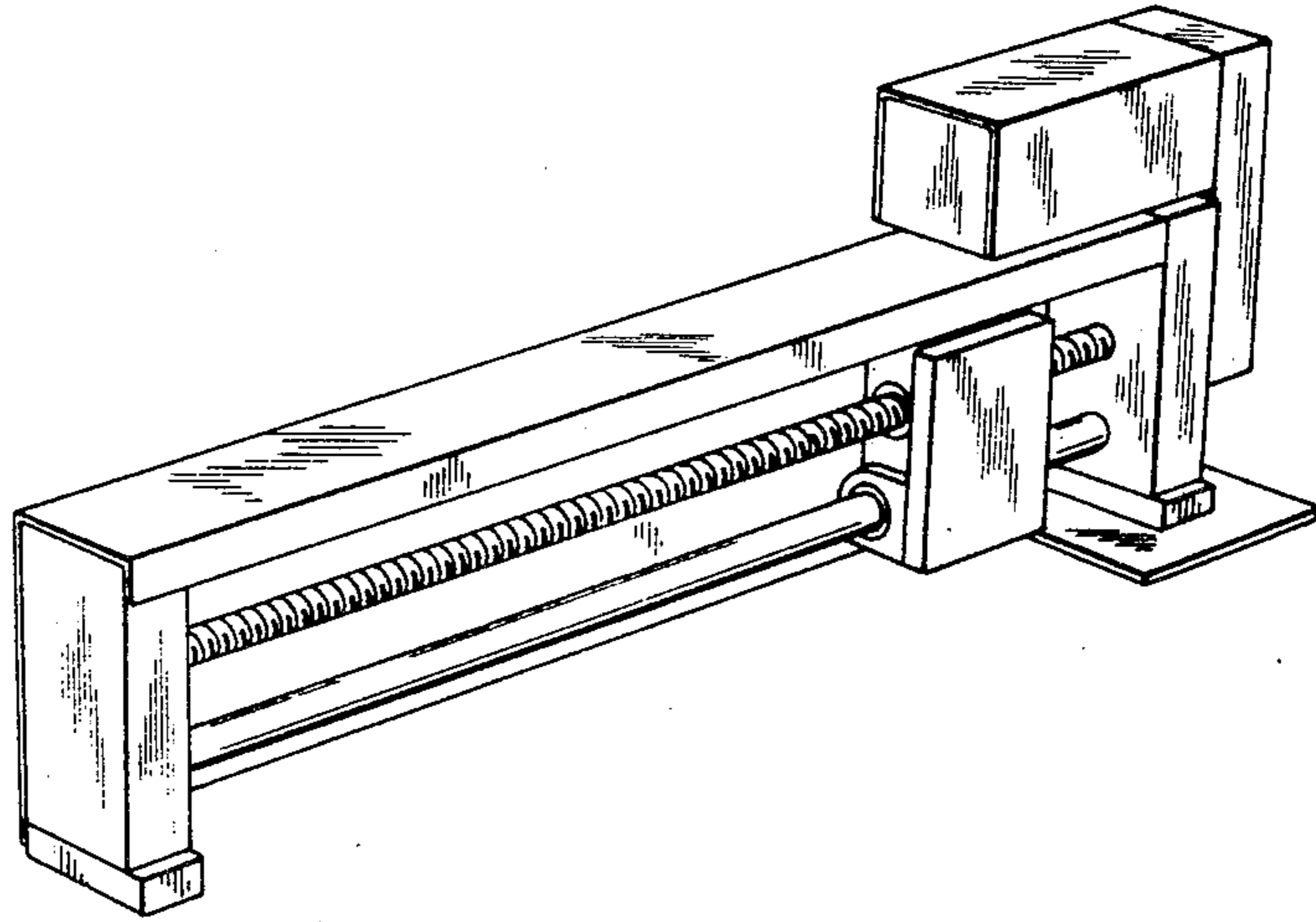

FIG. 2

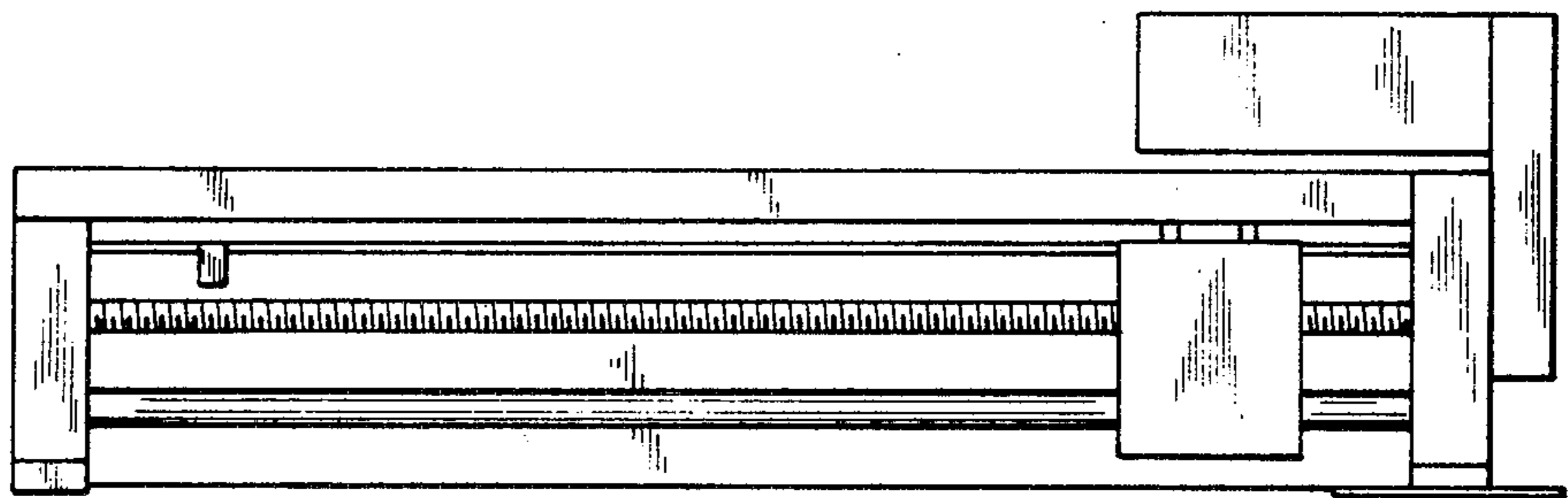

FIG. 3

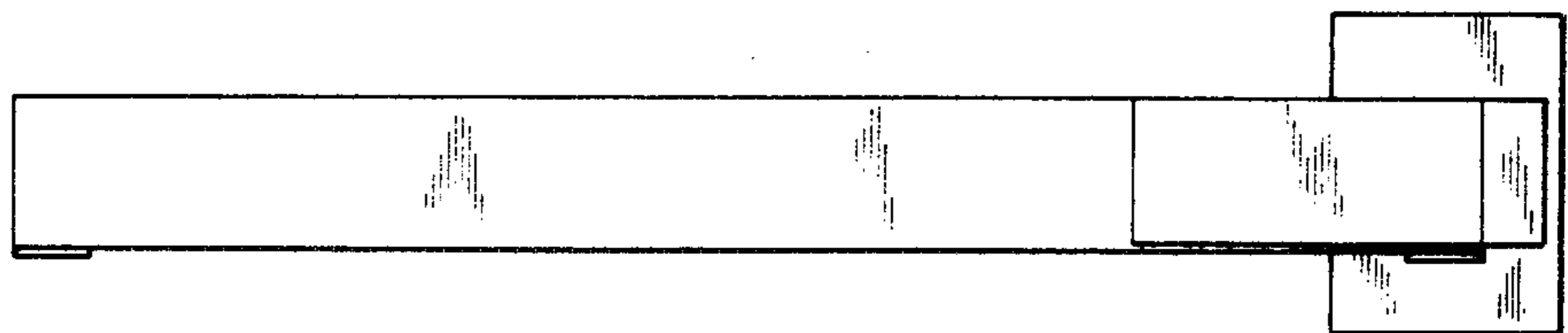

FIG. 4

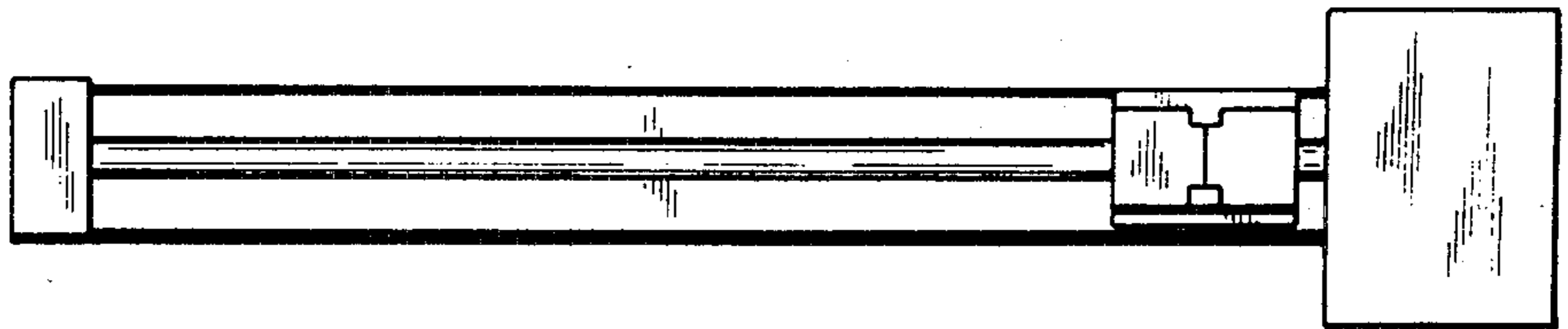

FIG. 5

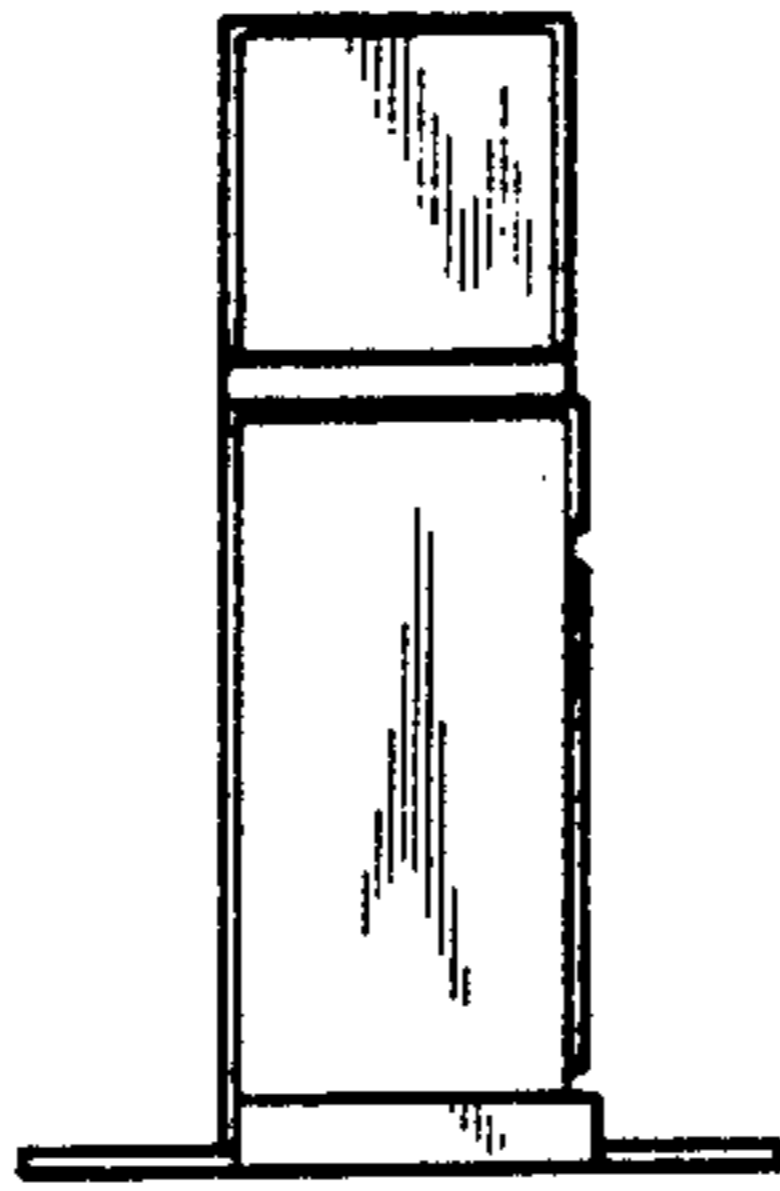

FIG. 6

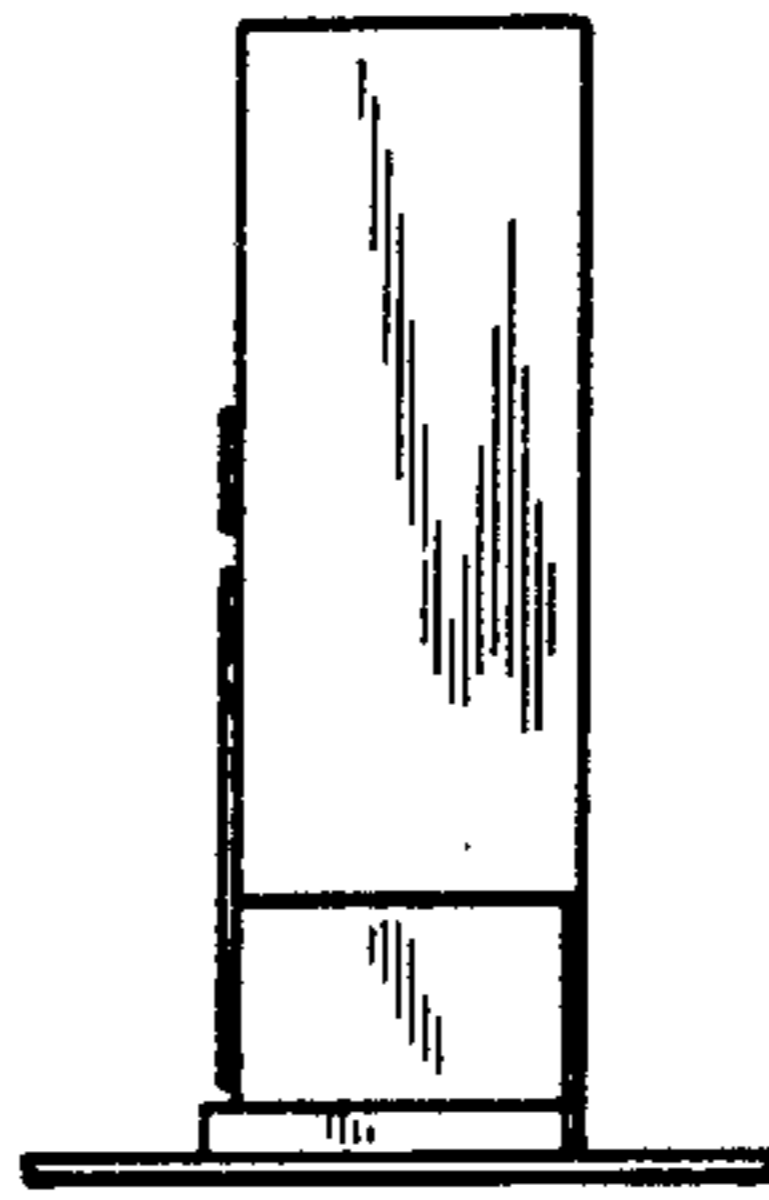

FIG. 7

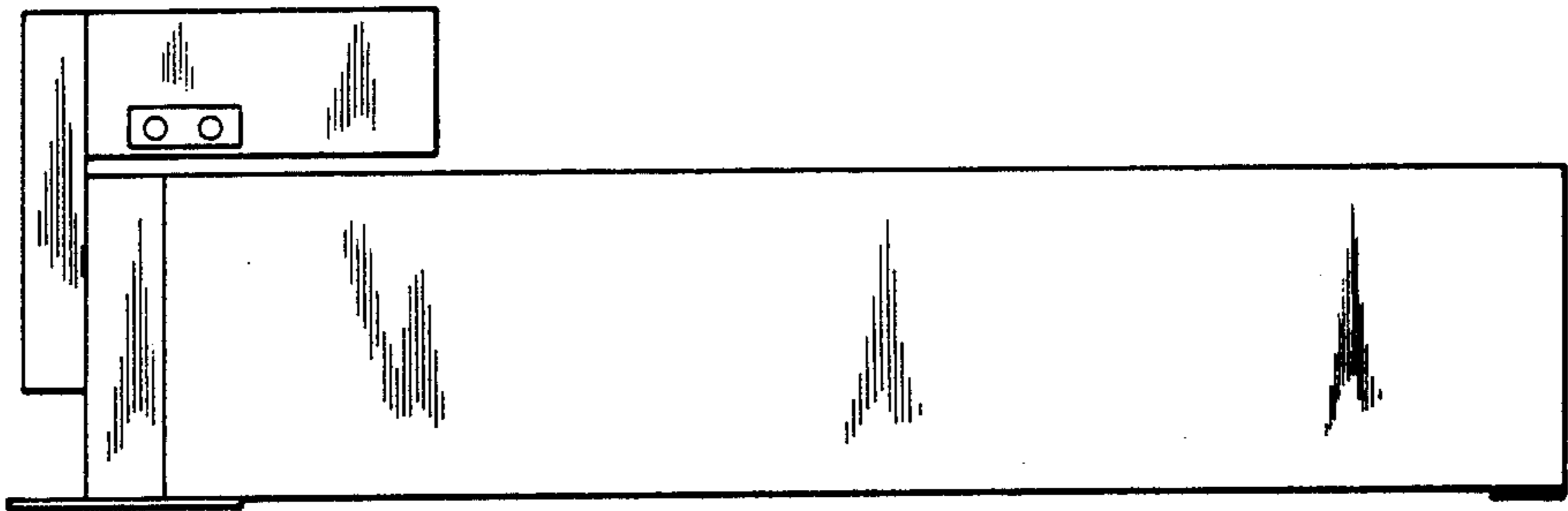

FIG. 8

