

[54] DEBRIS SEPARATOR DOWNSPOUT

[76] Inventor: Robert M. Williams, 10071 Atherton Rd., Davison, Mich. 48423

[\*\*] Term: 14 Years

[21] Appl. No.: 639,021

[22] Filed: Aug. 9, 1984

Related U.S. Application Data

[63] Continuation-in-part of Ser. No. 477,499, Mar. 21, 1983.

[52] U.S. Cl. .... D23/45

[58] Field of Search ..... D23/40-47; 210/162, 163, 164, 446, 447

[56] References Cited

U.S. PATENT DOCUMENTS

D. 260,422	8/1981	Husted	.....	D23/45
289,473	12/1883	Van Tassel	.....	210/447
522,667	7/1894	Minnemeyer	.....	210/447
543,922	8/1895	Buckley	.....	210/447 X
617,032	1/1899	Martin	.....	210/447 X
694,440	3/1902	Stair	.....	210/447 X
1,044,601	11/1912	Thiem	.....	210/447
1,076,075	10/1913	Steele	.....	210/447
1,136,538	4/1915	Kuenzli	.....	210/447 X
1,254,125	1/1918	Dash	.....	210/447 X
1,265,772	5/1918	Groo	.....	210/447 X
1,383,547	7/1921	Konsalik	.....	210/447 X
1,653,473	12/1927	Schulz	.....	210/447 X
2,419,501	4/1947	Pinto	.....	210/316

2,494,780	1/1950	Schmidt	.....	210/357
2,532,388	12/1950	Batt, Jr.	.....	210/447
3,421,629	1/1969	Hehr	.....	210/447
3,465,885	9/1969	Trump	.....	210/447
3,956,133	5/1976	Arnold	.....	210/447
4,472,274	9/1984	Williams	.....	210/163

Primary Examiner—James R. Largen  
Attorney, Agent, or Firm—Gifford, Groh, VanOphem, Sheridan, Sprinkle and Dolgorukov

[57] CLAIM

The ornamental design for a debris separator downspout, as shown and described.

DESCRIPTION

FIG. 1 is a right side elevational view of a debris separator downspout showing my new design;  
 FIG. 2 is a perspective view taken from the top, front and right side thereof;  
 FIG. 3 is a left side elevational view thereof;  
 FIG. 4 is a top plan view thereof;  
 FIG. 5 is a front elevational view thereof;  
 FIG. 6 is a rear elevational view thereof;  
 FIG. 7 is a bottom plan view thereof;  
 FIG. 8 is a perspective view taken from the top, front and right side of a modified form of the debris separator downspout shown in FIG. 1;  
 FIG. 9 is a right side elevational view of FIG. 8;  
 FIG. 10 is a left side elevational view of FIG. 8;  
 FIG. 11 is a top plan view of FIG. 8;  
 FIG. 12 is a front elevational view of FIG. 8;  
 FIG. 13 is a rear elevational view of FIG. 8; and  
 FIG. 14 is a bottom plan view of FIG. 8.

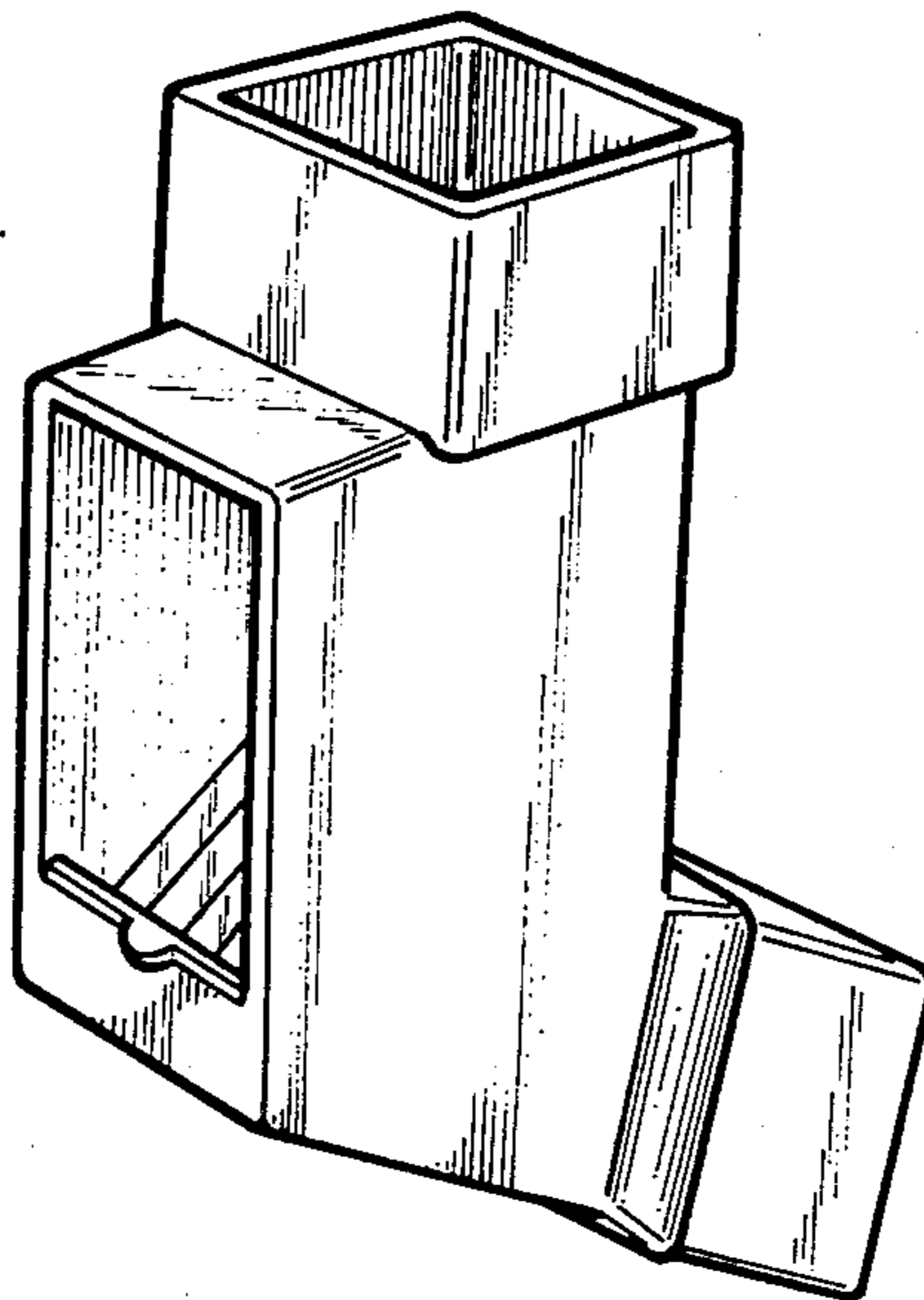

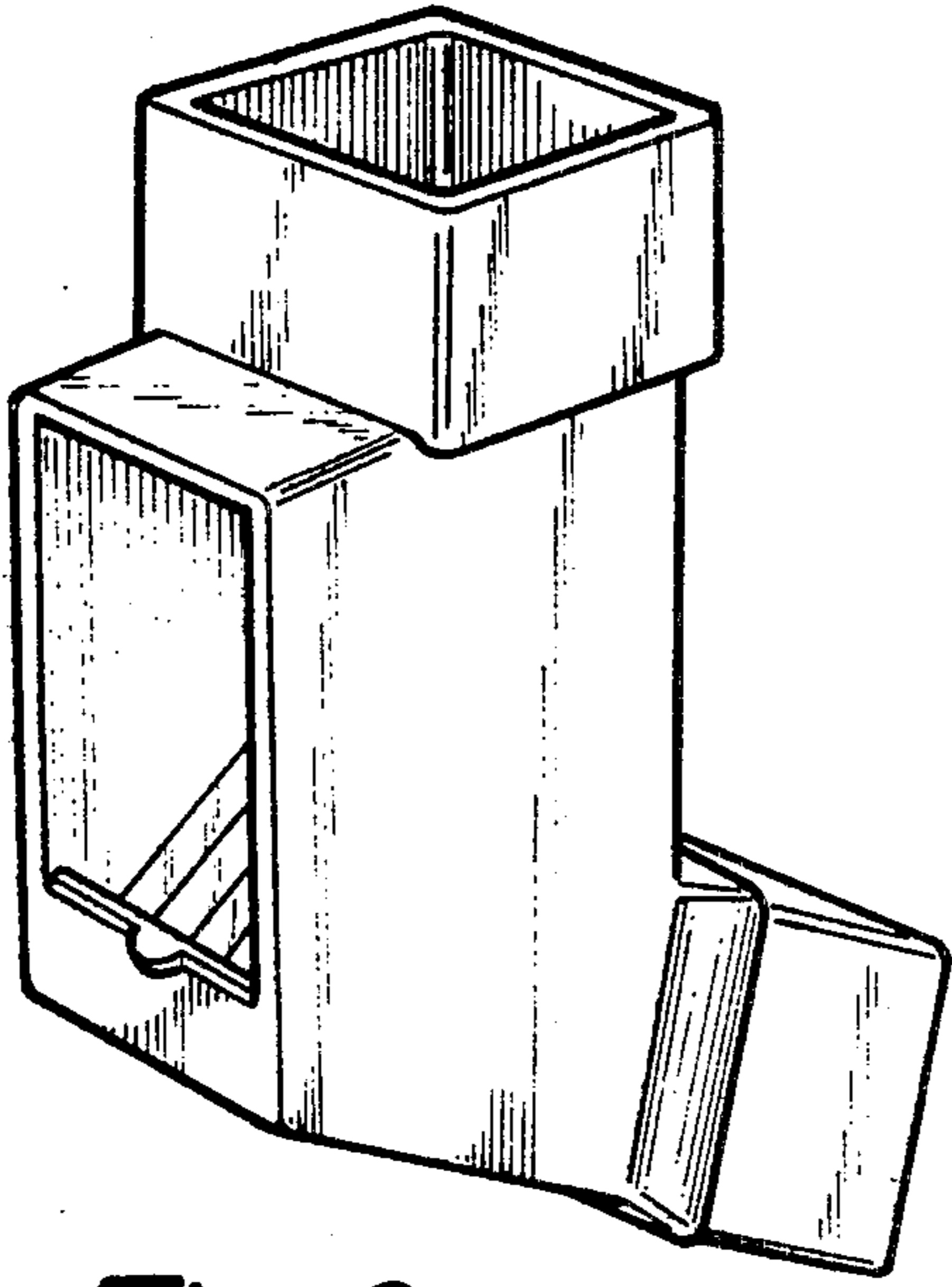

Fig-2

Fig-1

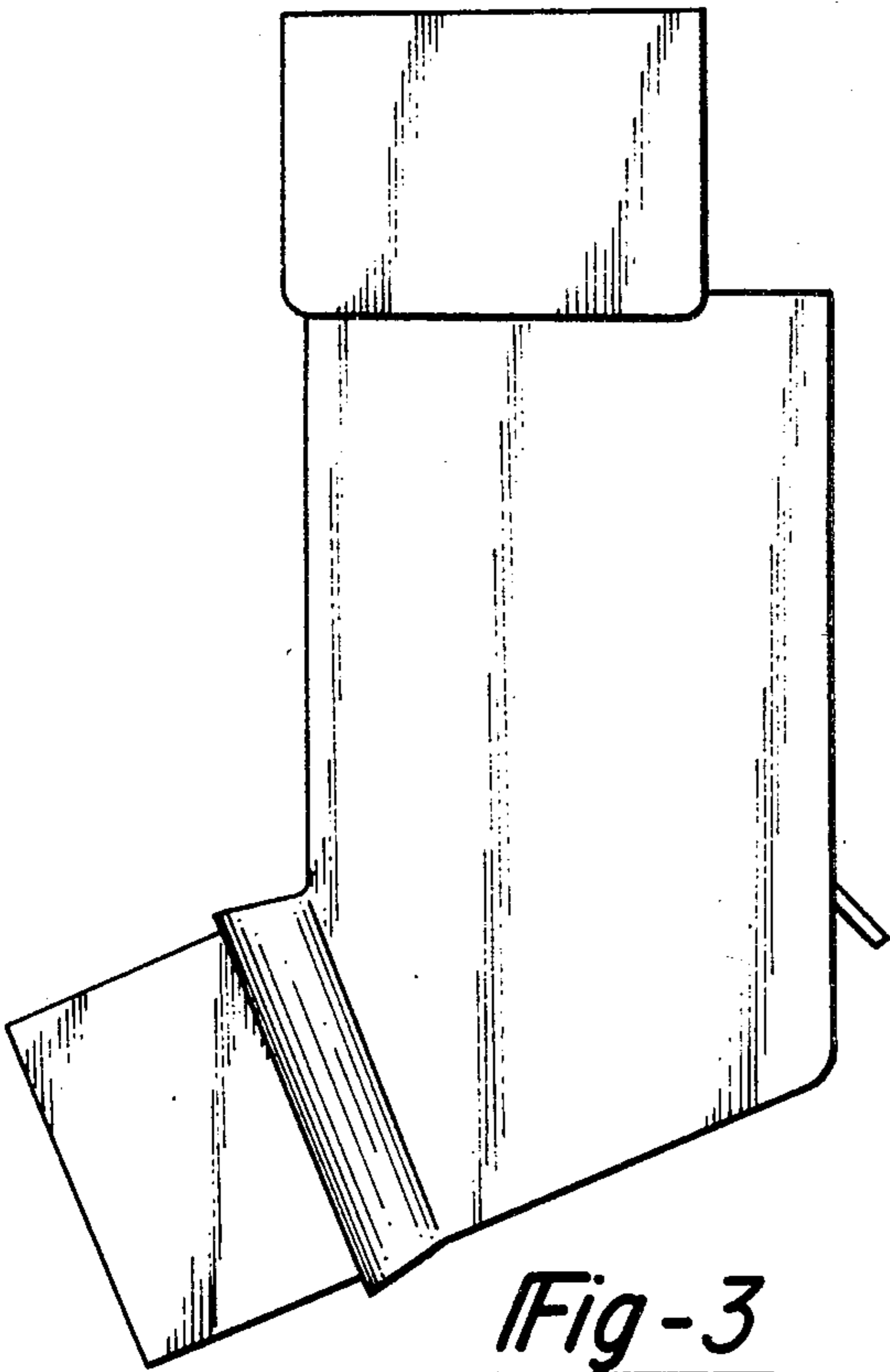
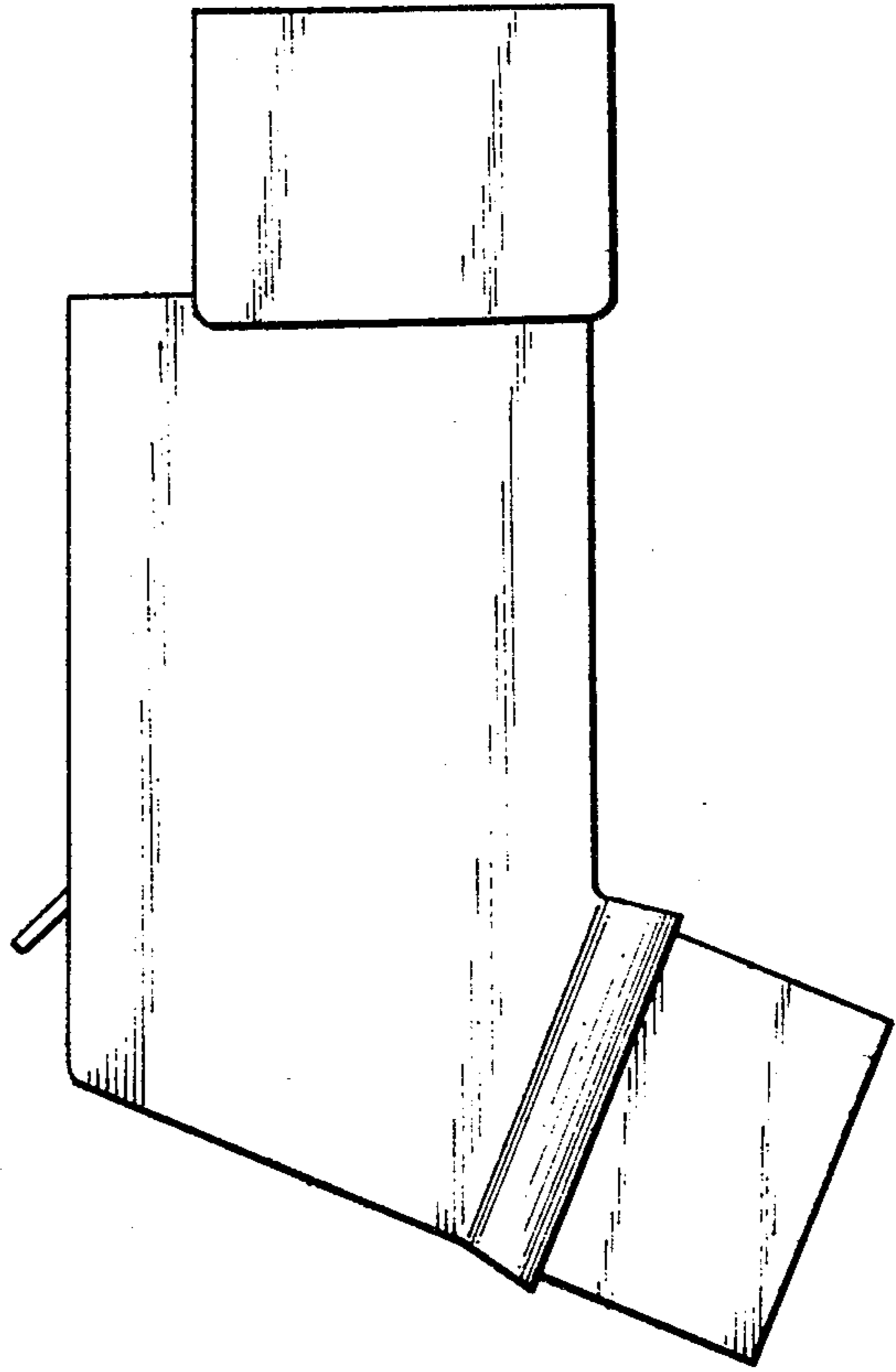

Fig-3

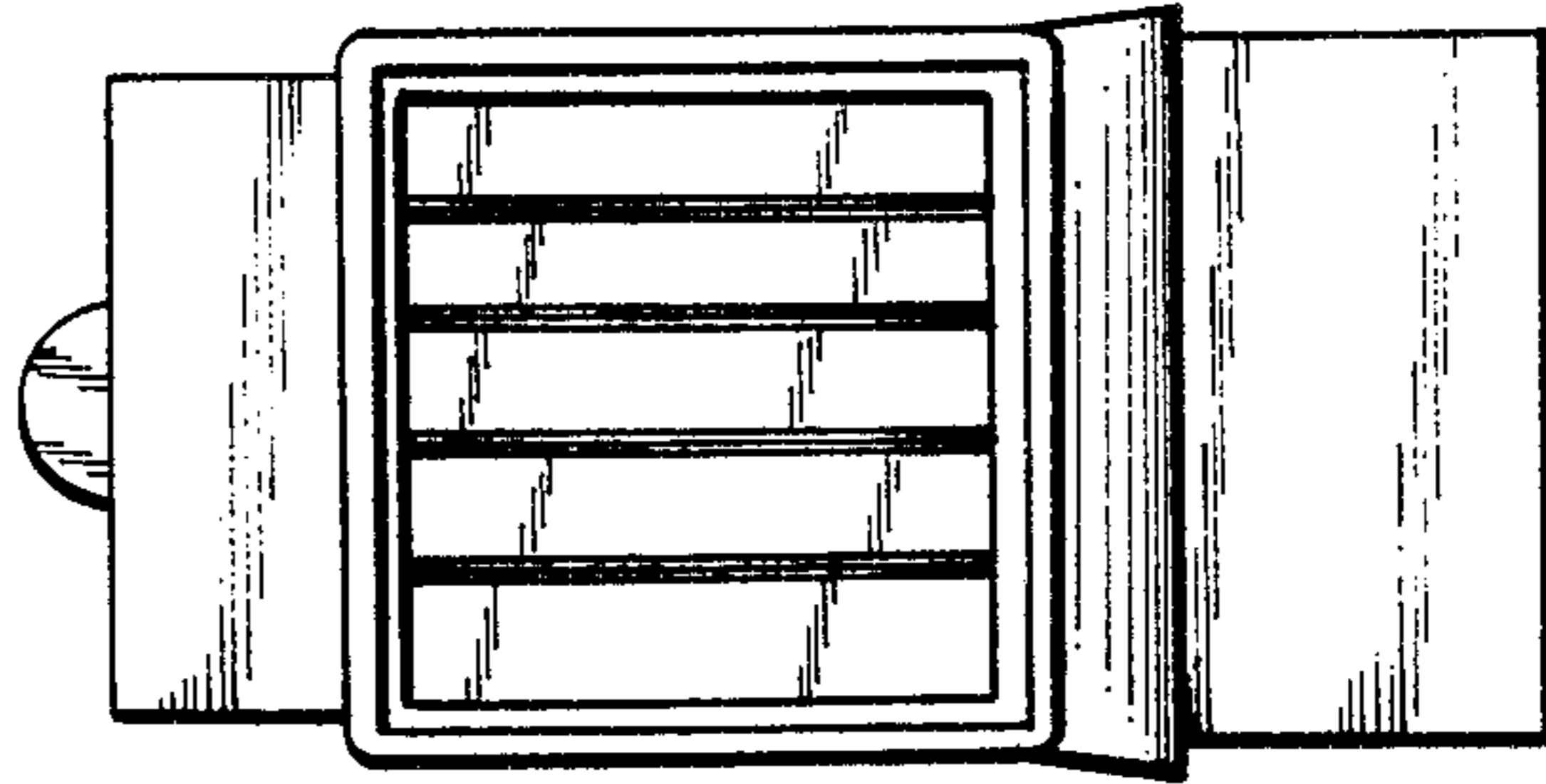

Fig-4

Fig-5

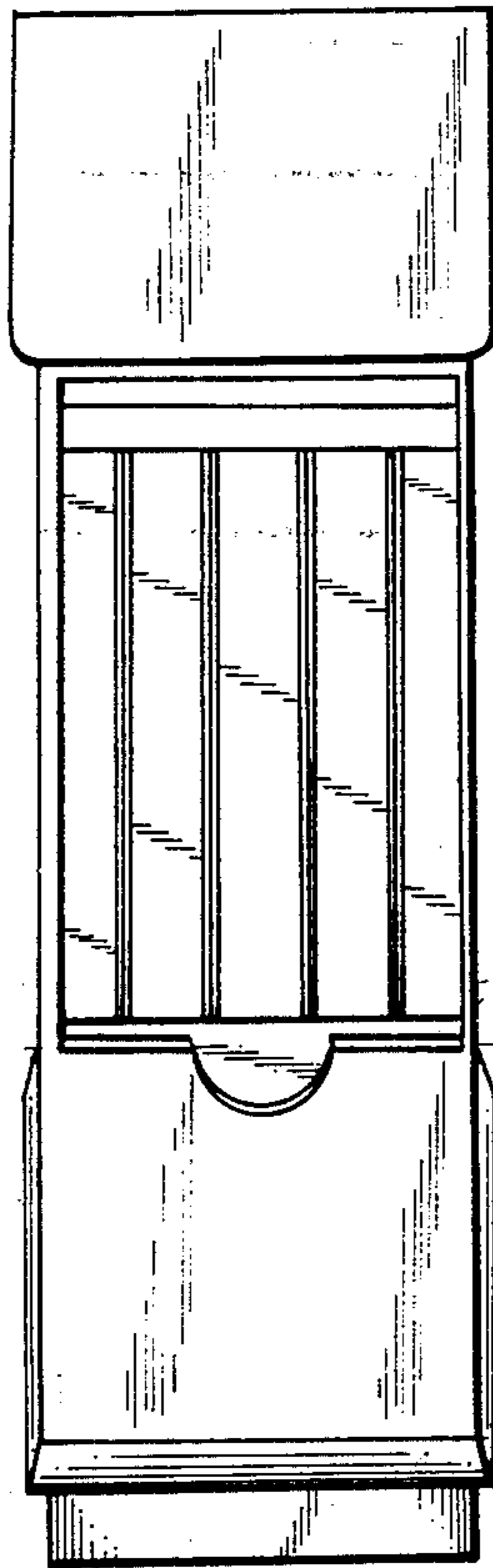

Fig-6

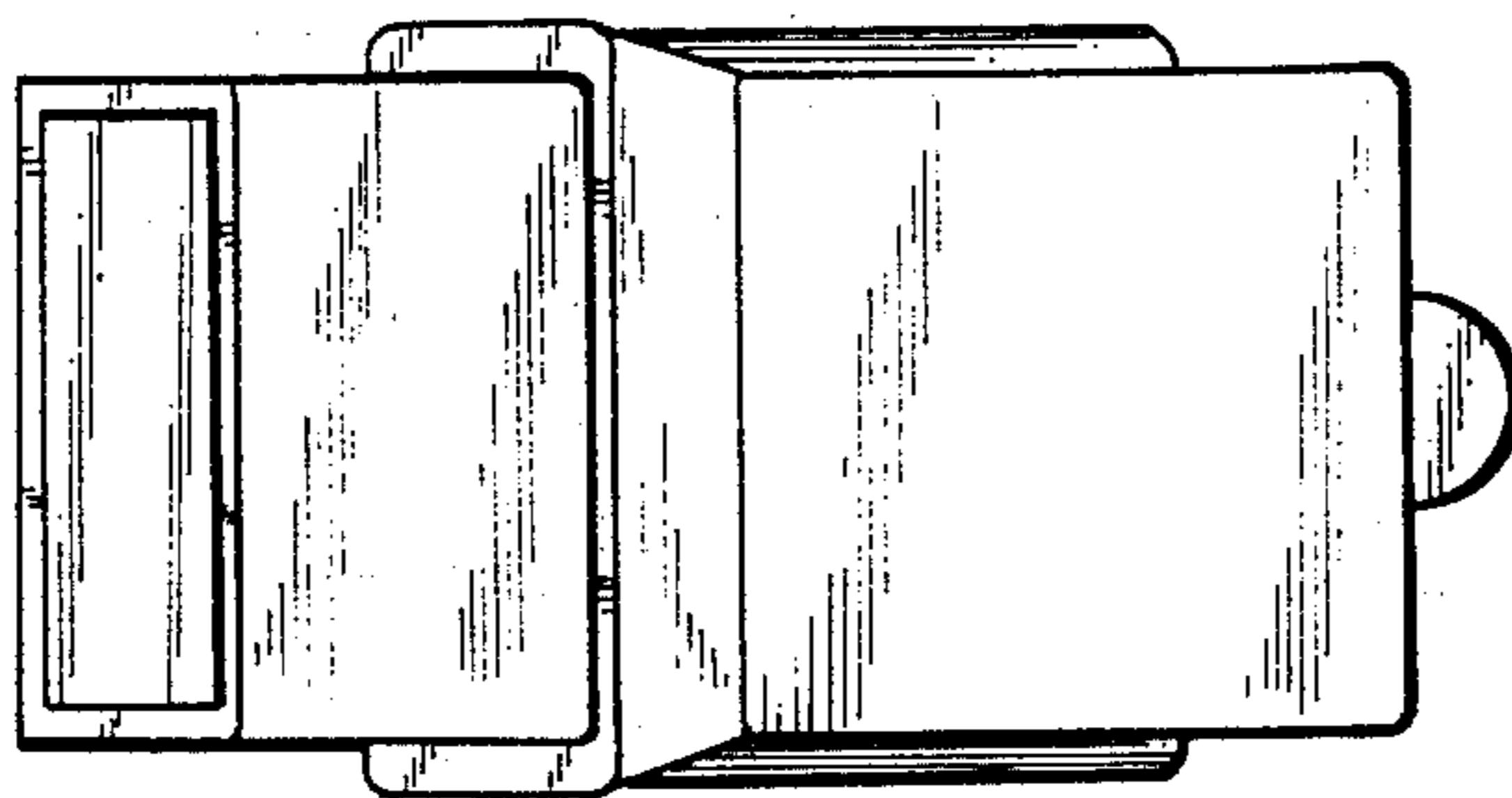
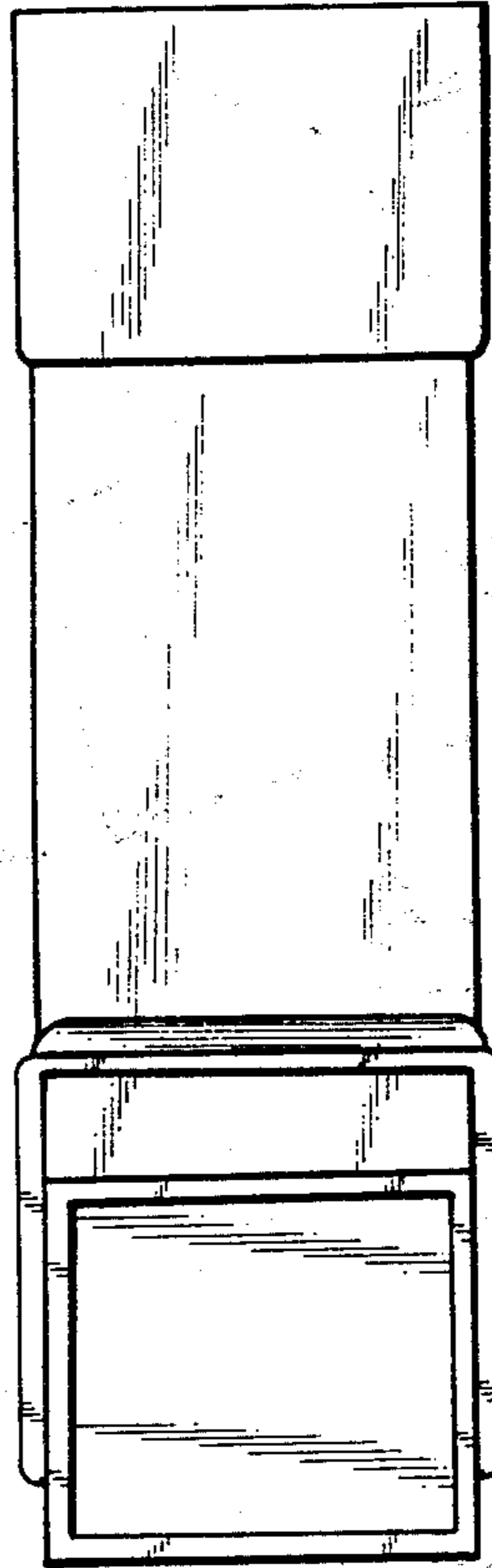

Fig-7

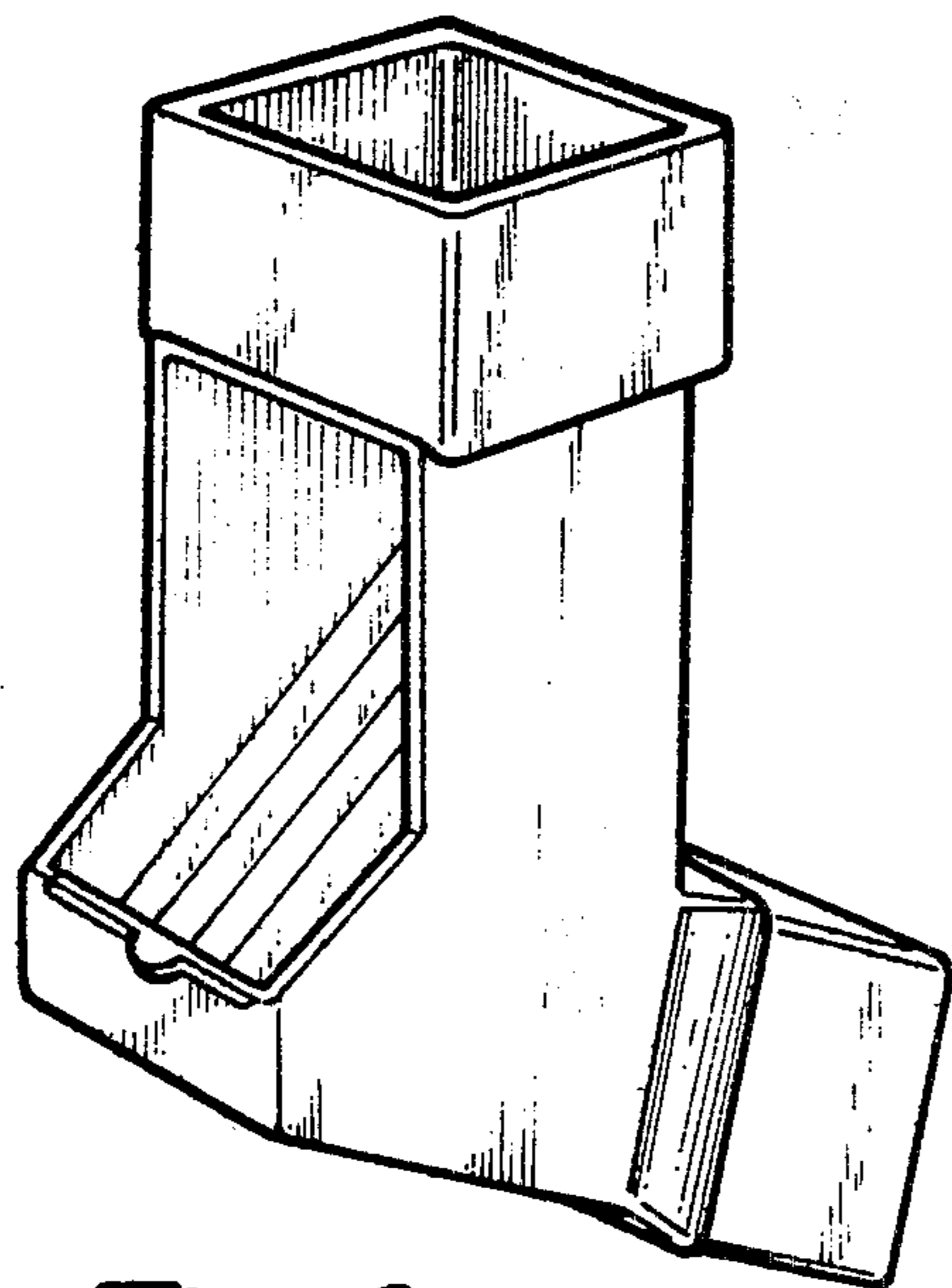

Fig-8

Fig-9

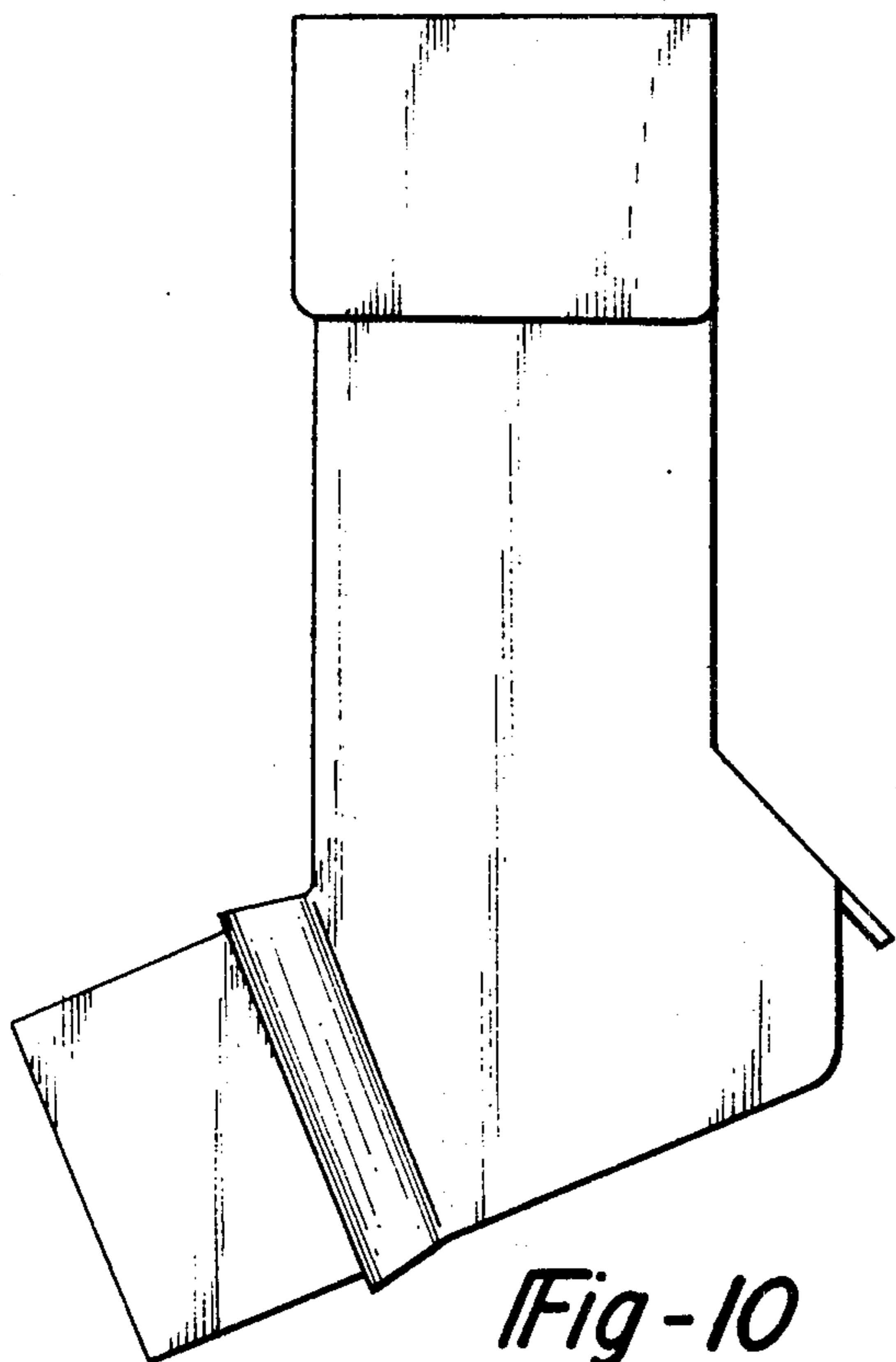
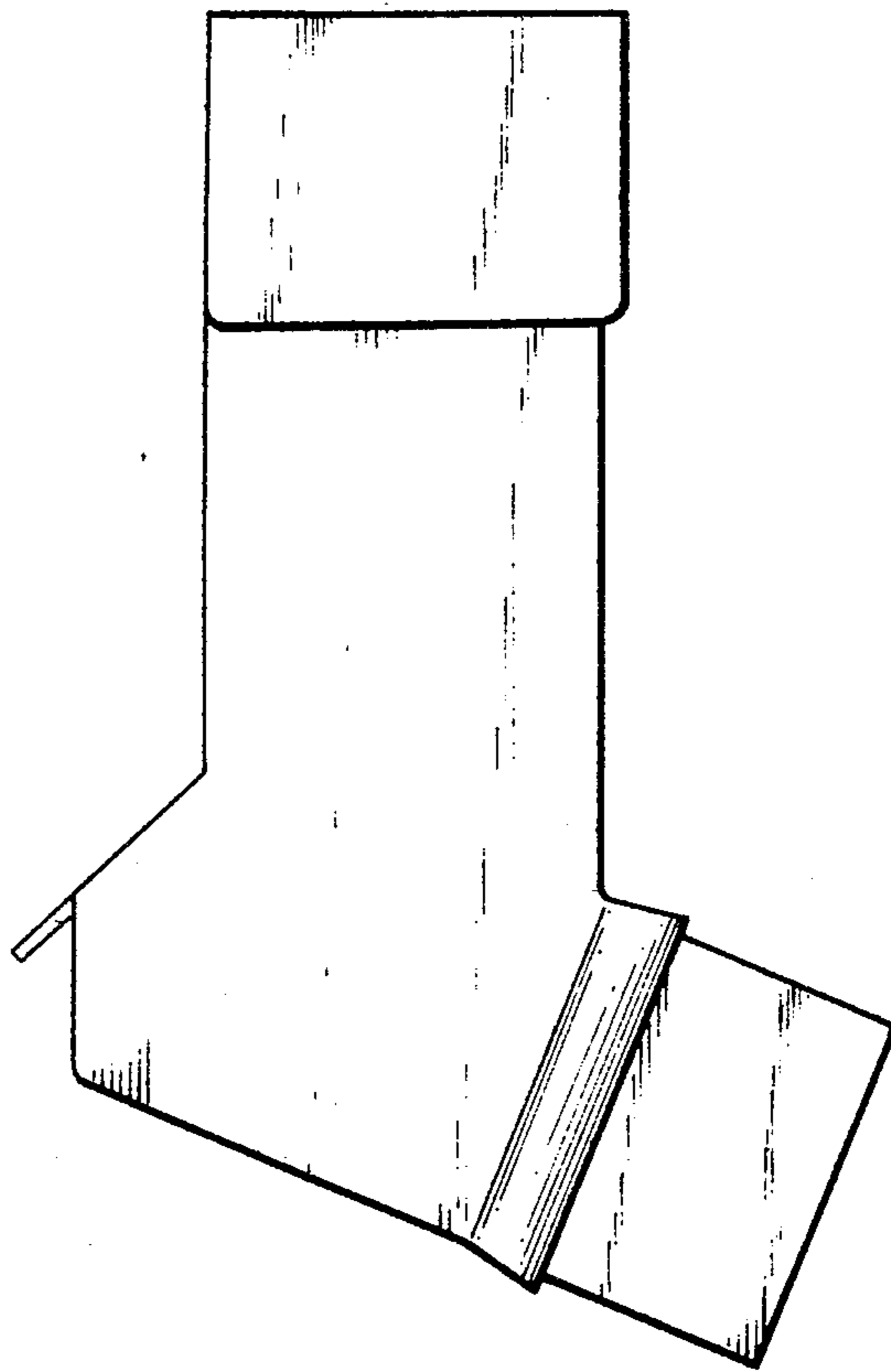

Fig-10

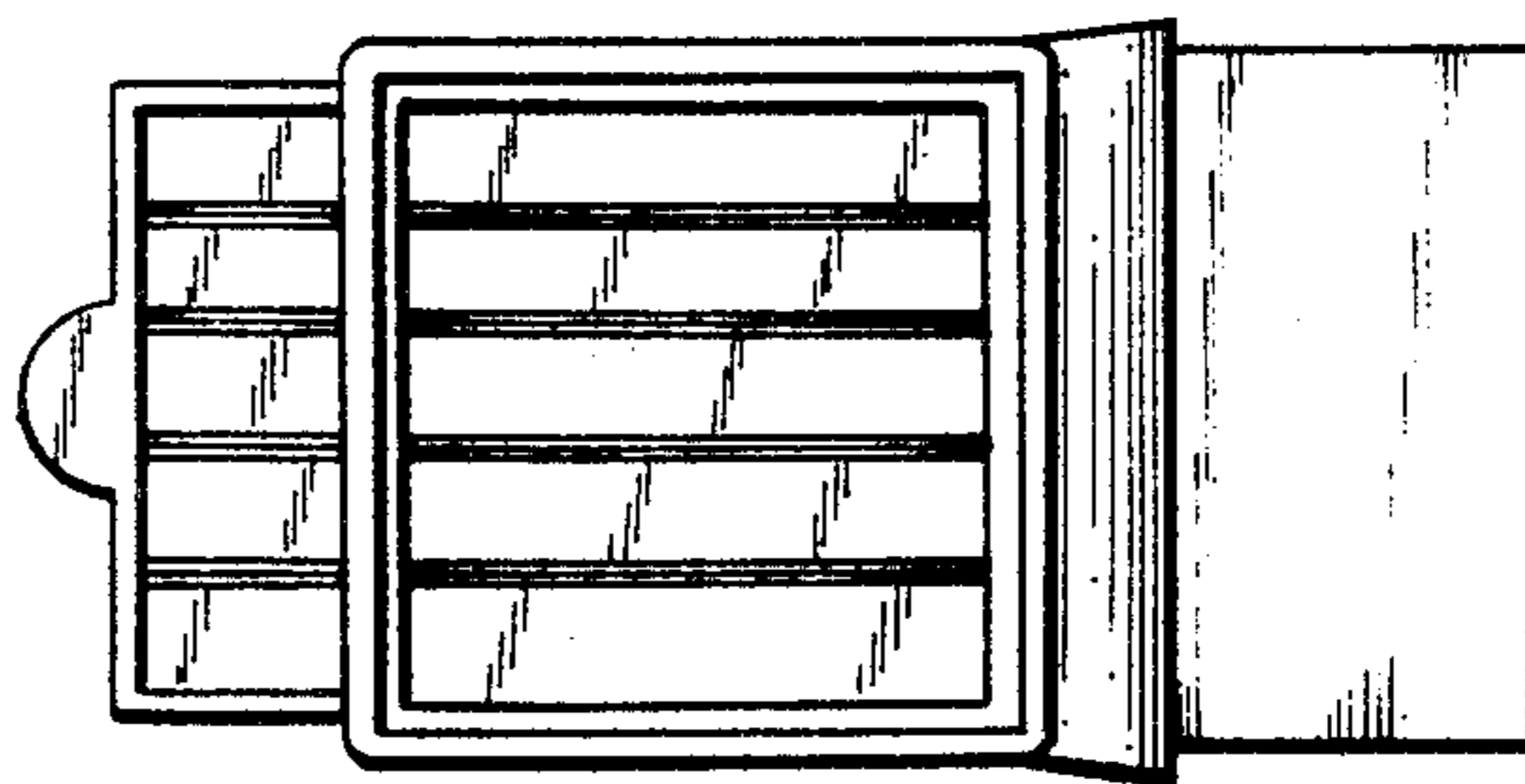

Fig-11

Fig-12

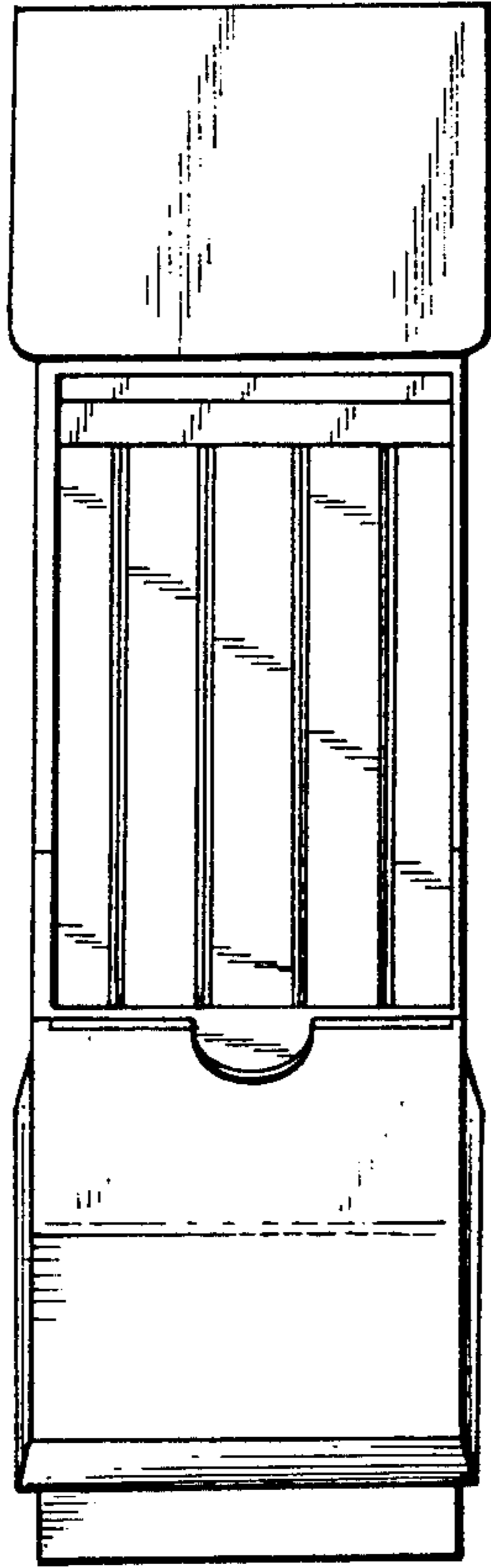

Fig-13

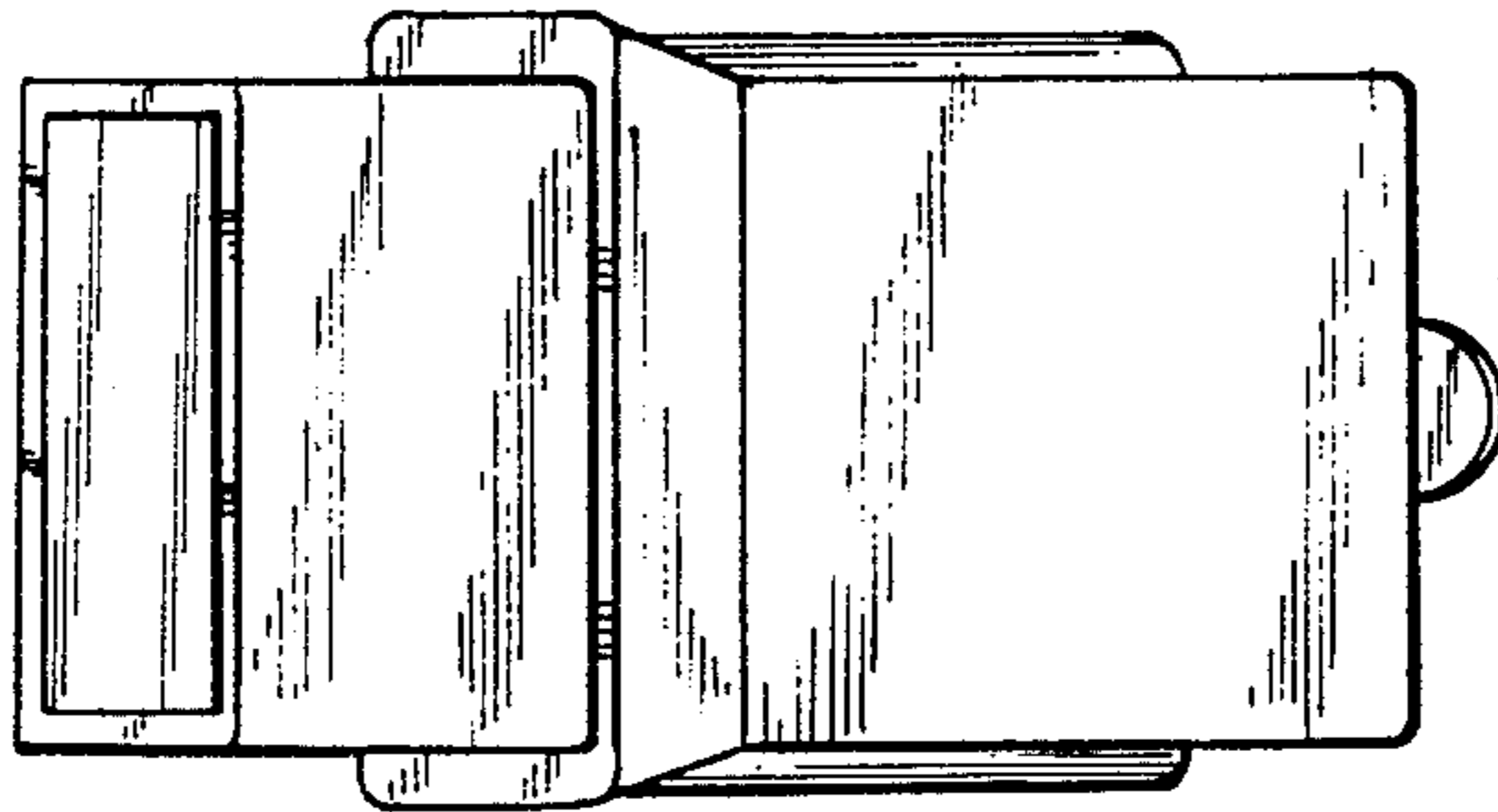
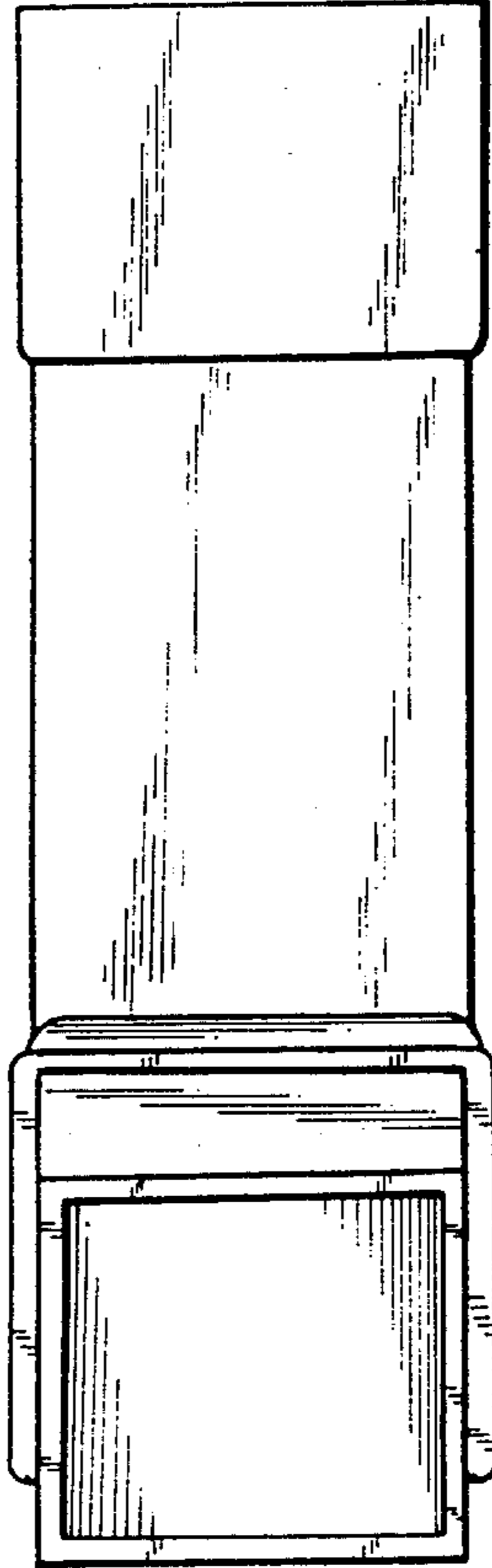

Fig-14