

[54] **VEHICLE WHEEL LOCKING NUT**

[76] **Inventor: Kee J. Kwon, 15914 Septo St., Sepulveda, Calif. 91343**

[**] **Term: 14 Years**

[21] **Appl. No.: 554,269**

[22] **Filed: Nov. 22, 1983**

[52] **U.S. Cl. D8/397**

[58] **Field of Search D8/397; 81/10, 121 R, 81/436; 411/402, 403, 407, 410, 910**

[56] **References Cited**

U.S. PATENT DOCUMENTS

- D. 241,520 9/1976 Fujita et al. D8/397
- D. 243,317 2/1977 Fukuyama D8/397
- 3,241,408 3/1966 McCauley 81/436

- 3,874,258 4/1975 Semola et al. 411/427
- 4,242,932 1/1981 Barmore 411/403
- 4,480,513 11/1984 McCauley et al. 81/436

Primary Examiner—B. J. Bullock
Attorney, Agent, or Firm—Bogucki, Scherlacher, Mok & Roth

[57] **CLAIM**

The ornamental design for a vehicle wheel locking nut, substantially as shown and described.

DESCRIPTION

FIG. 1 is a perspective view of a vehicle wheel locking nut showing my new design;
FIG. 2 is a right end elevational view thereof;
FIG. 3 is a left side elevational view thereof.
The undisclosed left end is conventional and unornamented.

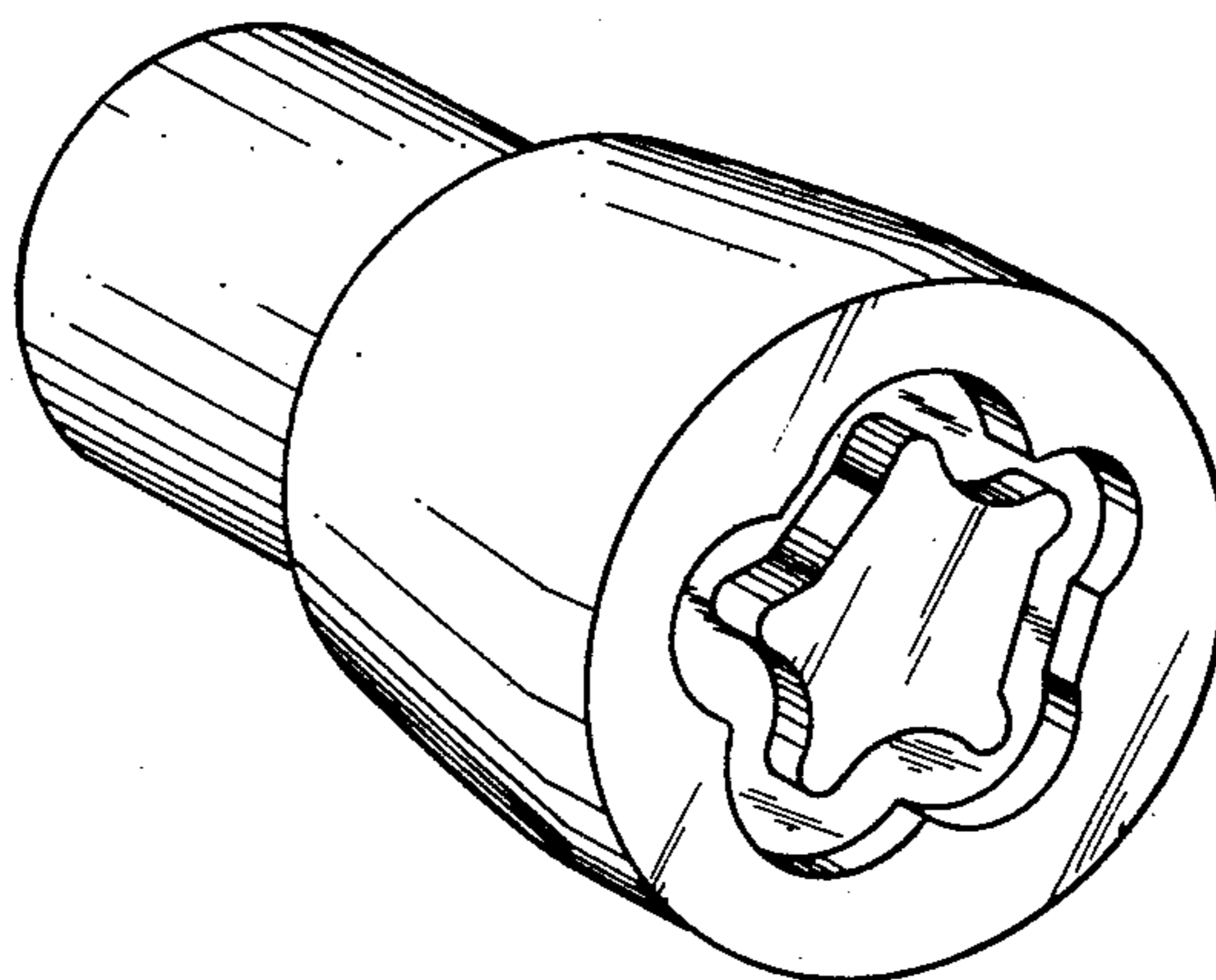

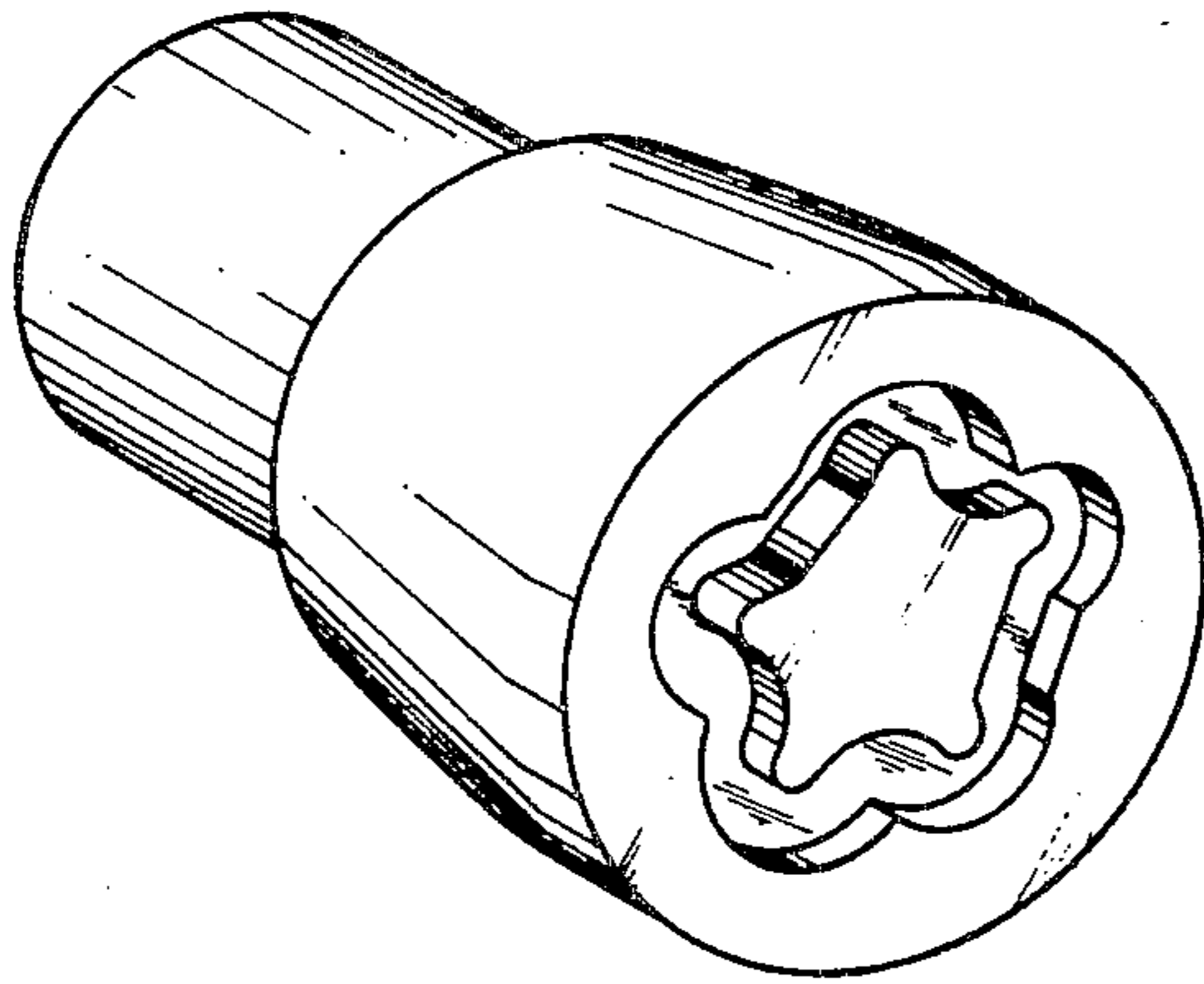

FIG. 1

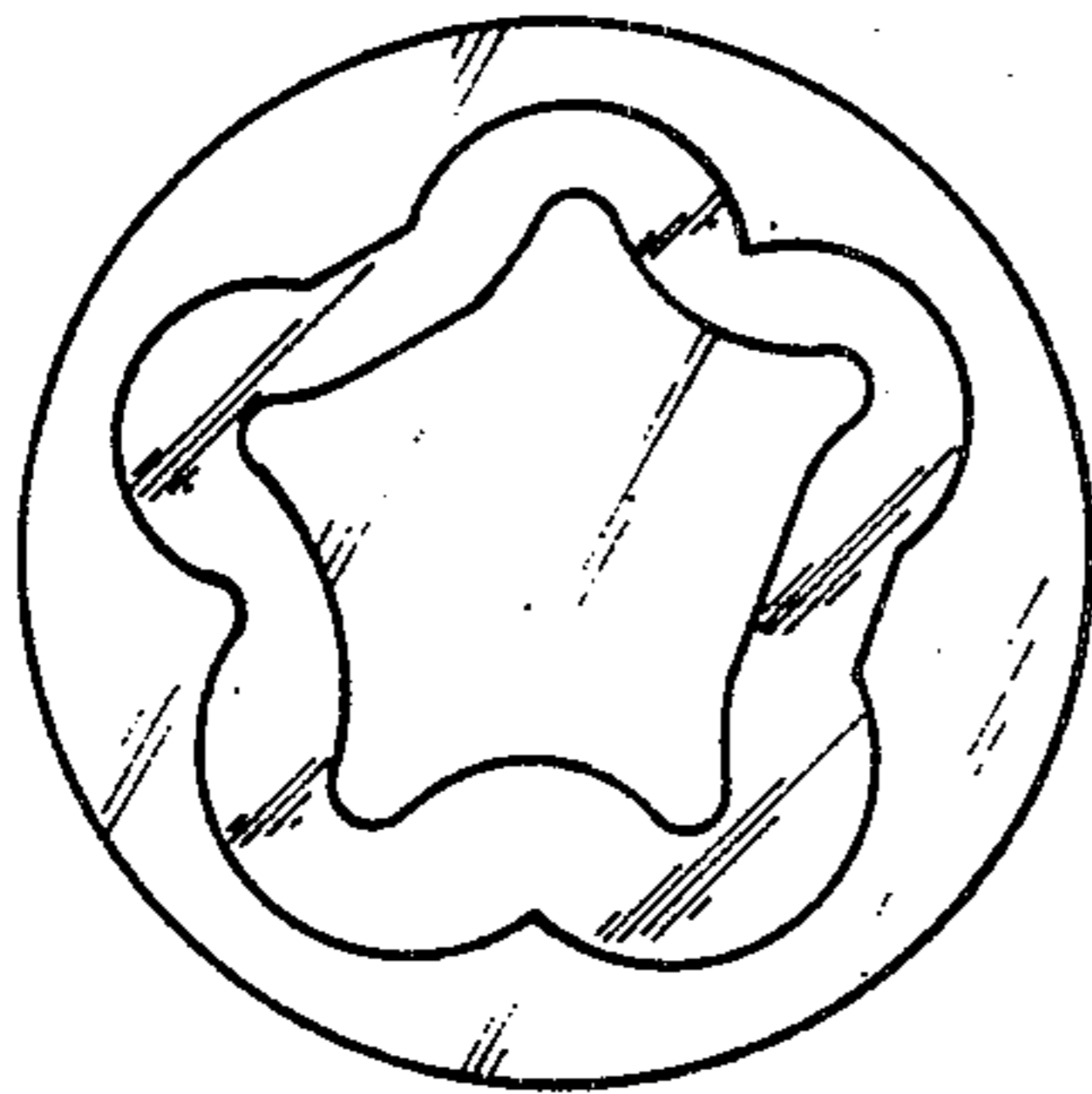

FIG. 2

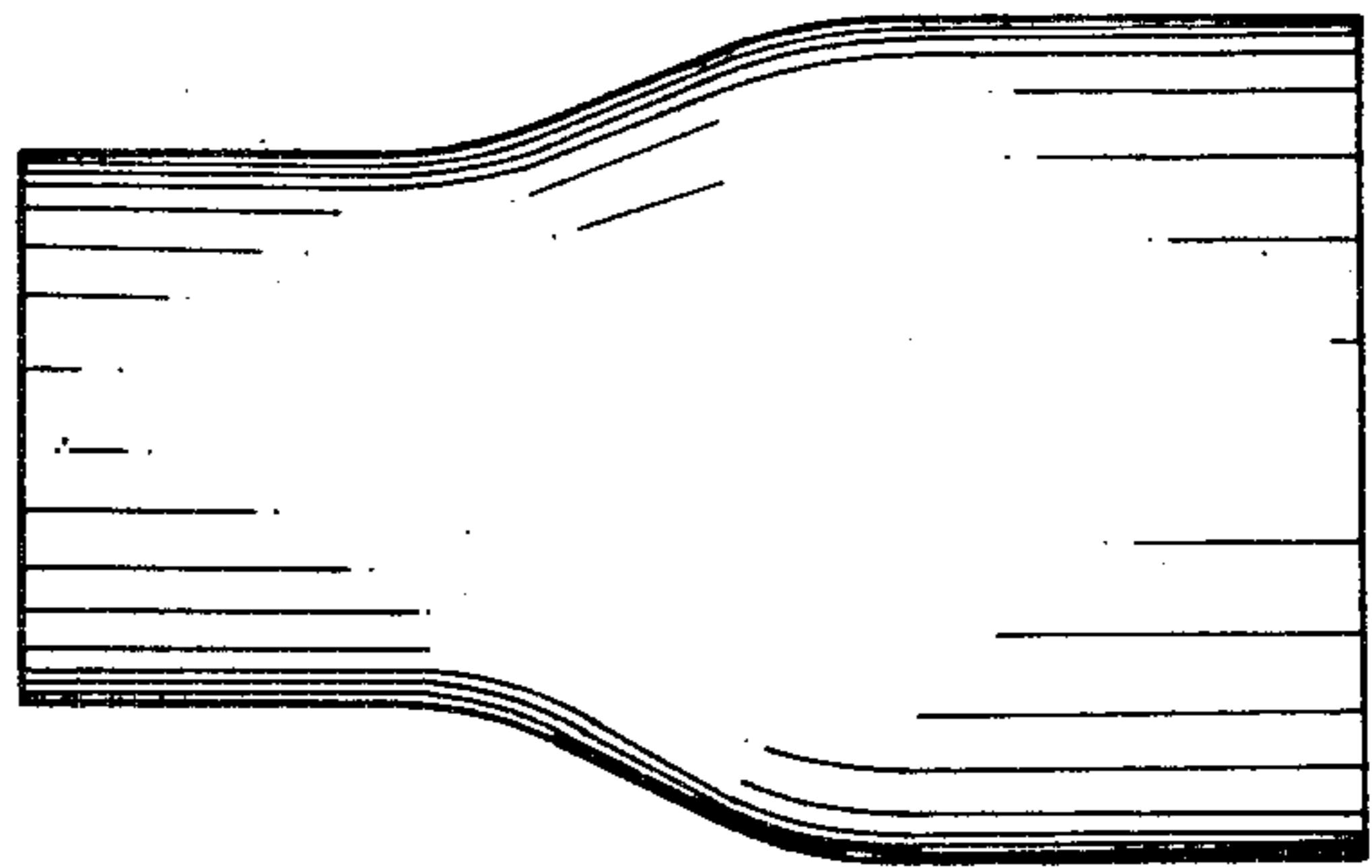

FIG. 3