

United States Patent [19]

Ward

[11] Patent Number: **Des. 288,773**

[45] Date of Patent: **** Mar. 17, 1987**

[54] **HOSE REEL**

[75] Inventor: **Arthur S. Ward, Melbourne, Australia**

[73] Assignee: **Plastex Corporation Pty. Ltd., Victoria, Australia**

[**] Term: **14 Years**

[21] Appl. No.: **743,764**

[22] Filed: **Jun. 12, 1985**

[30] **Foreign Application Priority Data**

Mar. 15, 1985 [AU] Australia 0645/85

[52] U.S. Cl. **D8/359**

[58] Field of Search **D8/358, 359; 191/12.4, 191/12.2 R; 242/107.7, 96, 71.9, 86.5, 106, 118.8, 118.7; D3/24**

[56] **References Cited**

U.S. PATENT DOCUMENTS

D. 147,372	8/1947	Marsh	D8/359
D. 211,531	6/1968	Elmslie	D8/359
D. 281,482	11/1985	Suzuki	D3/24 X
1,169,338	1/1916	Martin	191/12.2 R
2,178,192	10/1939	Tolliver	191/12.4 UX
2,301,104	11/1942	Yost	191/12.4

4,072,278	2/1978	Peterson	242/96
4,124,176	11/1978	Carlson et al.	242/115 X
4,174,809	11/1979	Arlemark	242/86.2
4,186,881	2/1980	Long	242/86.2
4,227,661	10/1980	King et al.	242/107.7

FOREIGN PATENT DOCUMENTS

508253 6/1939 United Kingdom 191/12.4

Primary Examiner—Wallace R. Burke
Assistant Examiner—Horace B. Fay
Attorney, Agent, or Firm—Stevens, Davis, Miller & Mosher

[57] **CLAIM**

The ornamental design for a hose reel, as shown and described.

DESCRIPTION

FIG. 1 is a partial right side, partial top and rear perspective view of a hose reel showing my new design; FIGS. 2 and 3 are respectively front and rear elevational views thereof; FIGS. 4 and 5 are respectively right and left side elevational views thereof; and FIGS. 6 and 7 are respectively top and bottom plan views, with the handle rotated 180° from its FIG. 1 position.

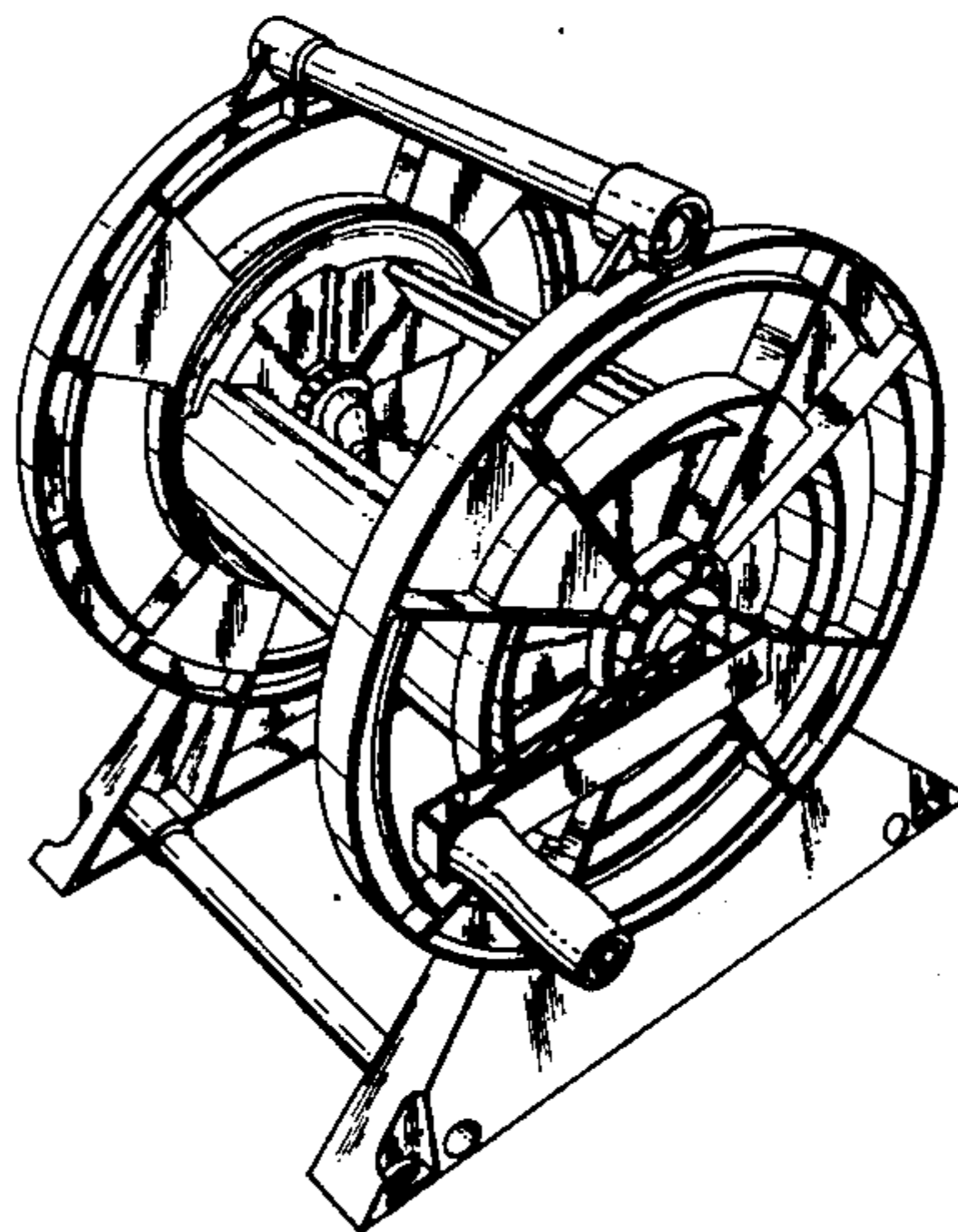

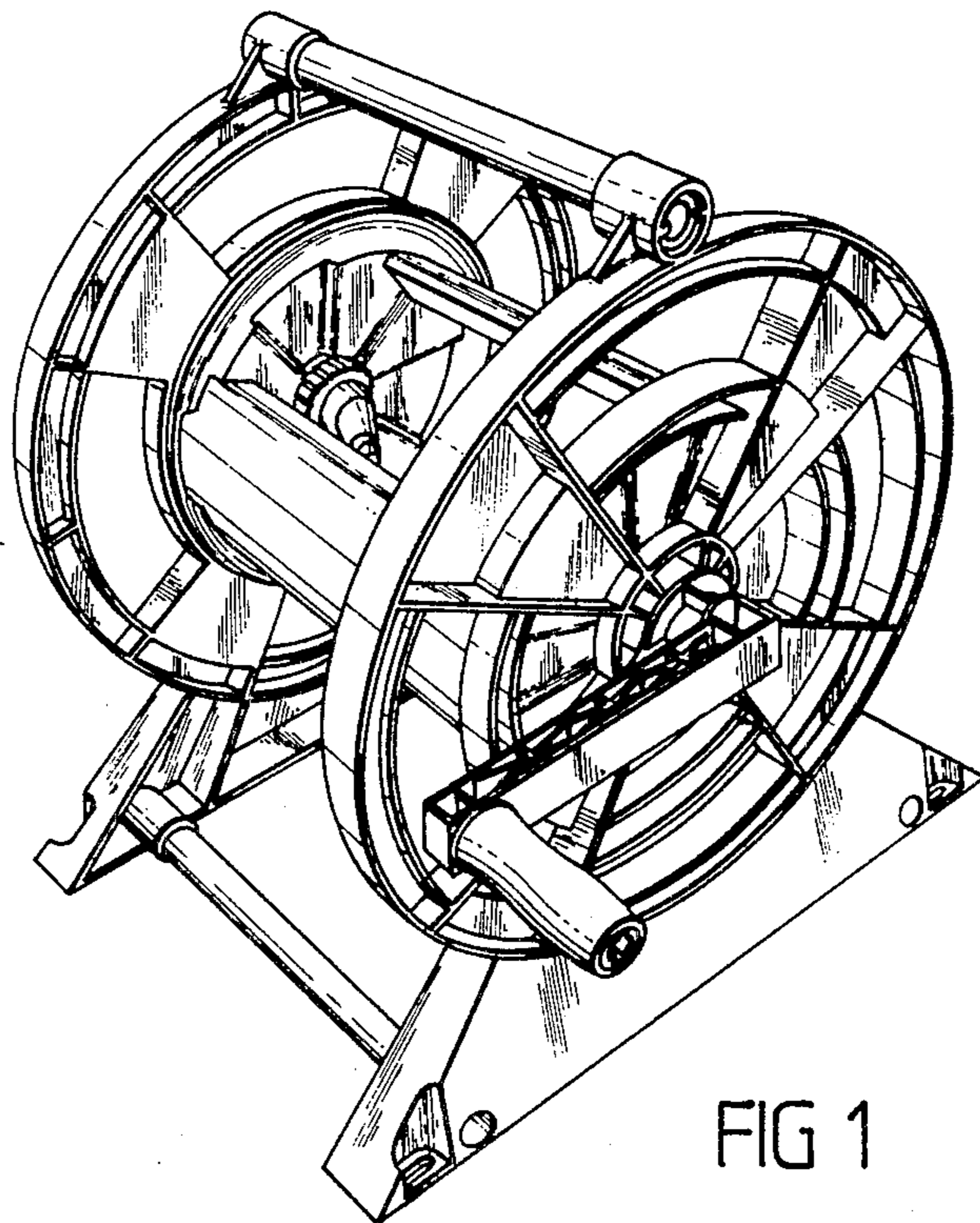

FIG 1

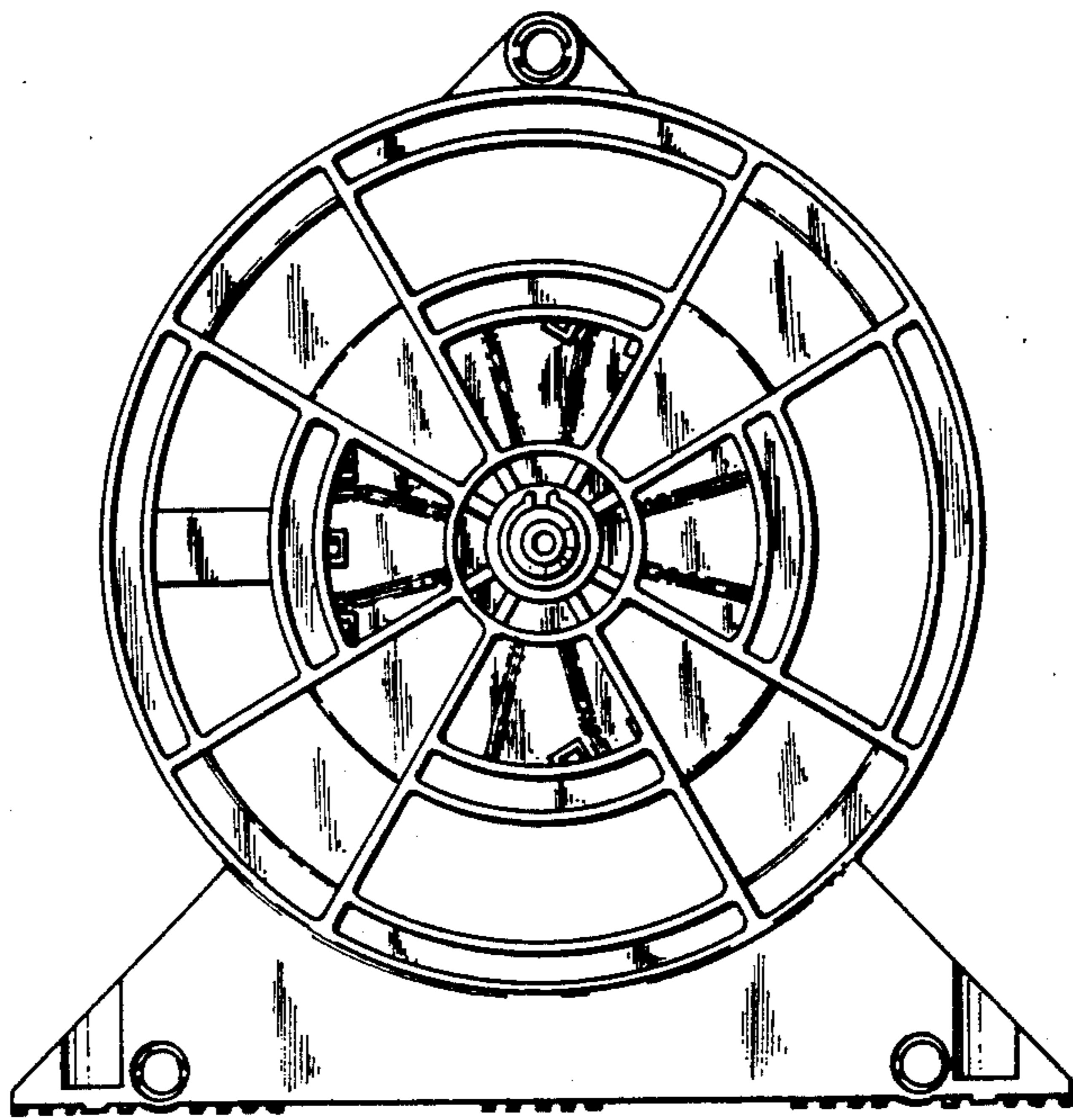

FIG 2

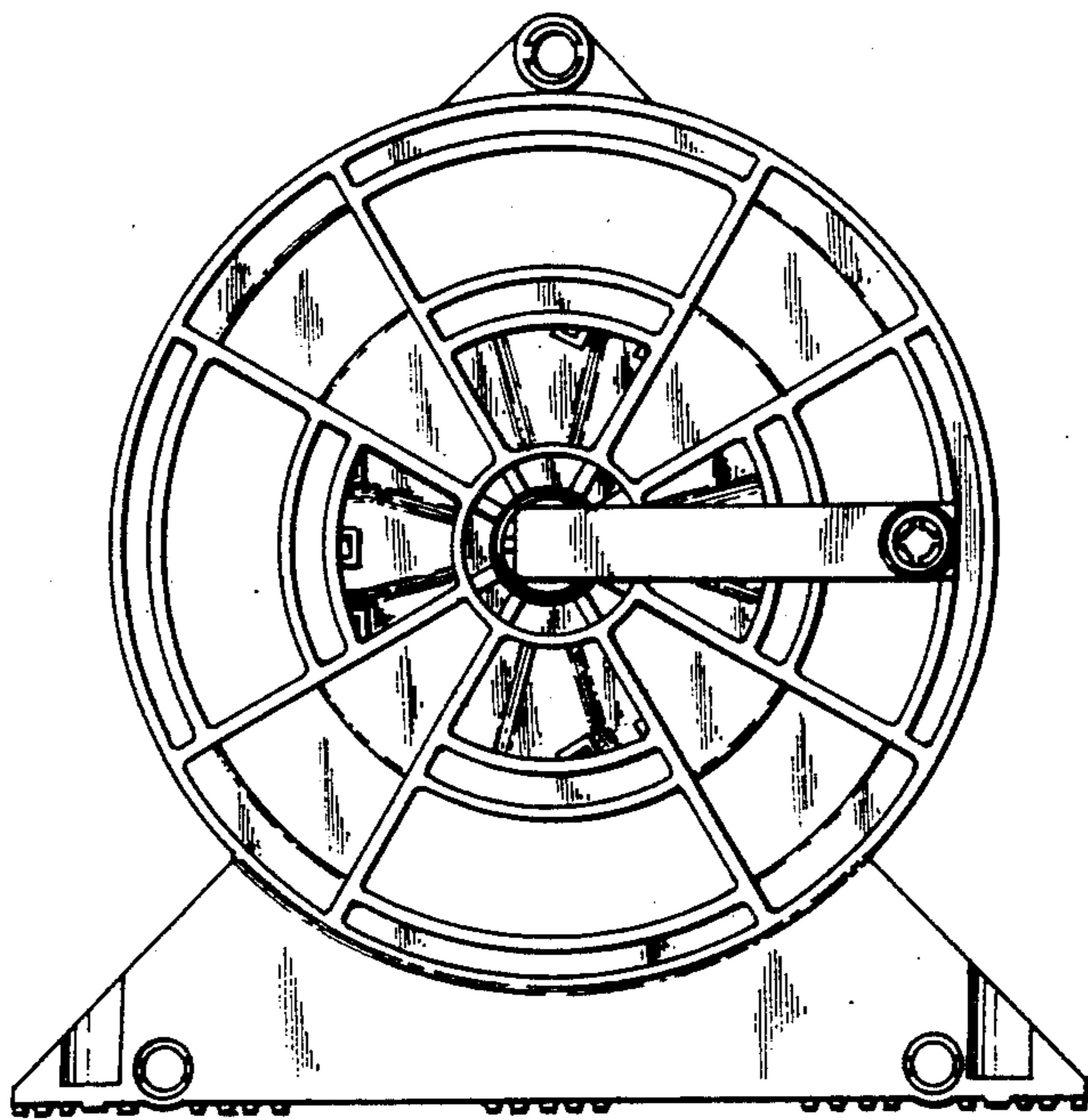

FIG 3

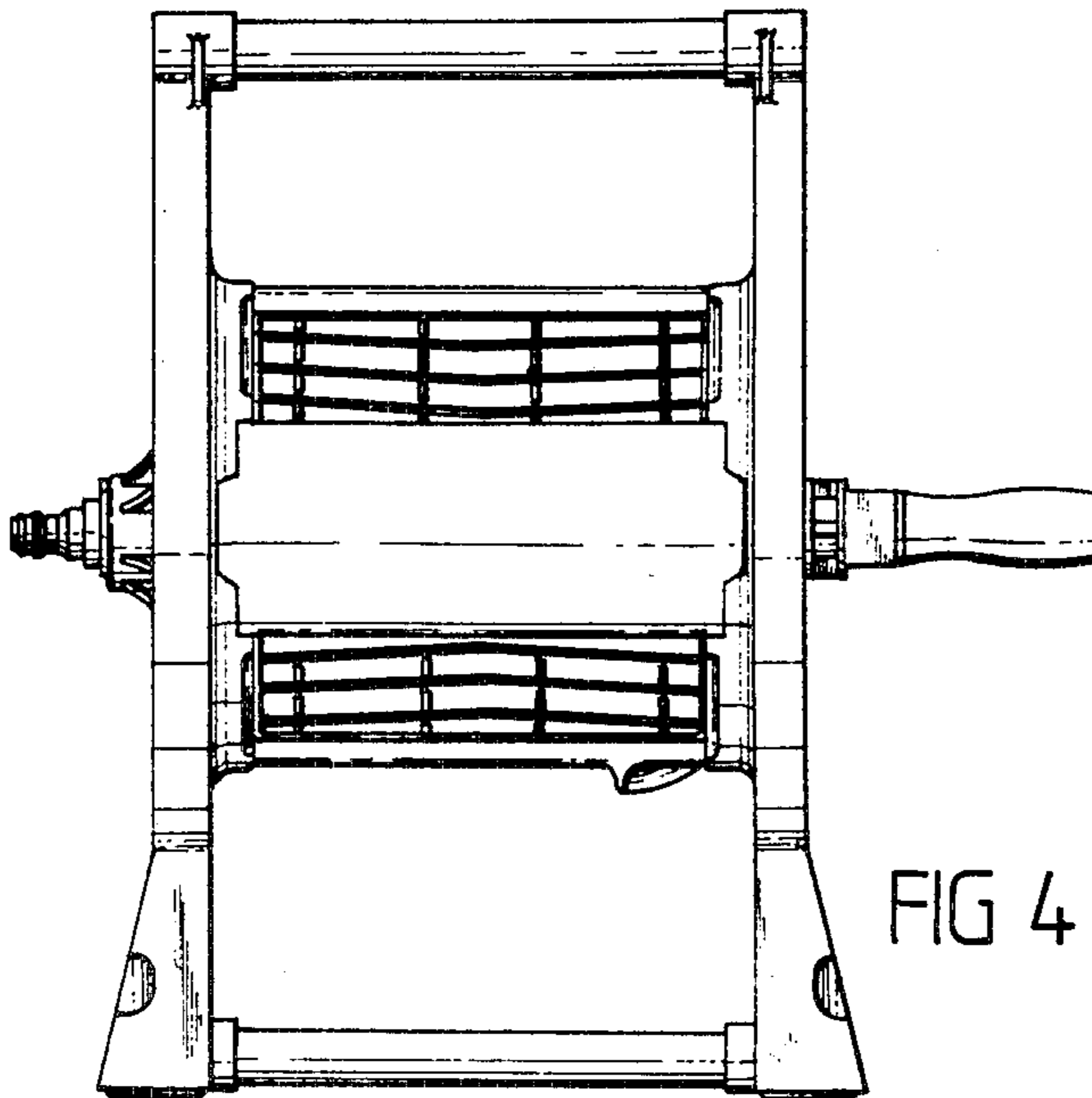

FIG 4

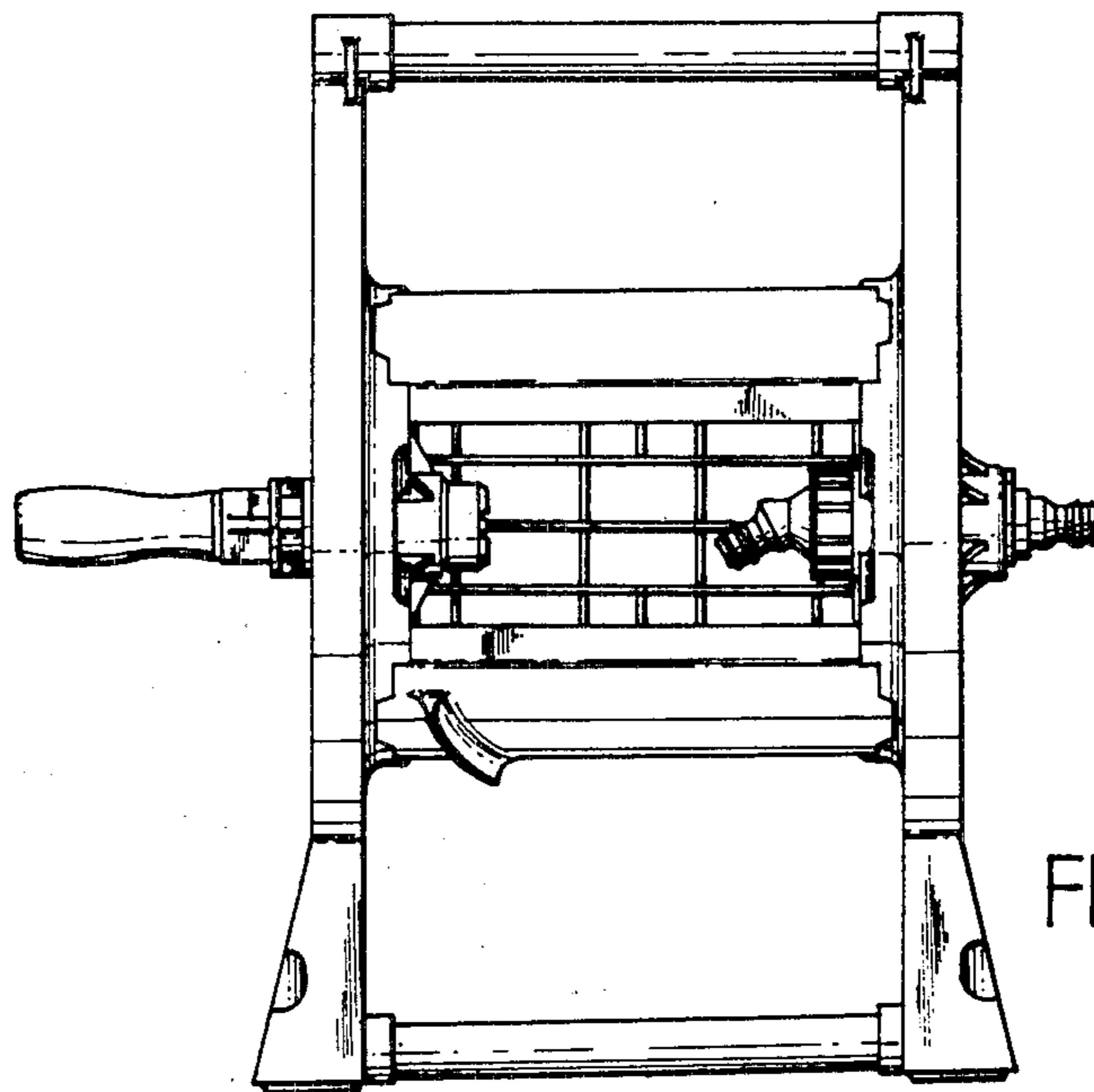

FIG 5

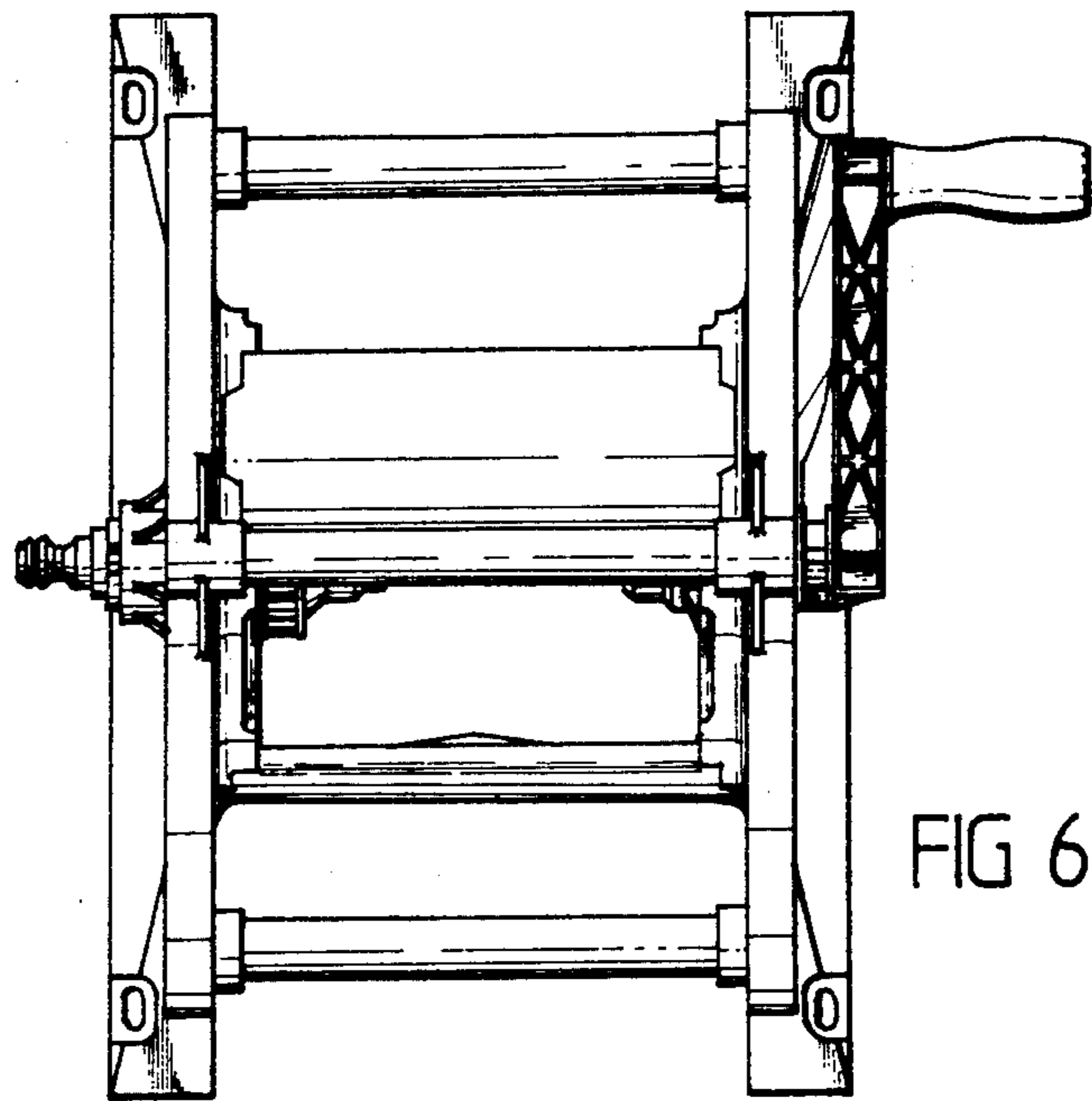

FIG 6

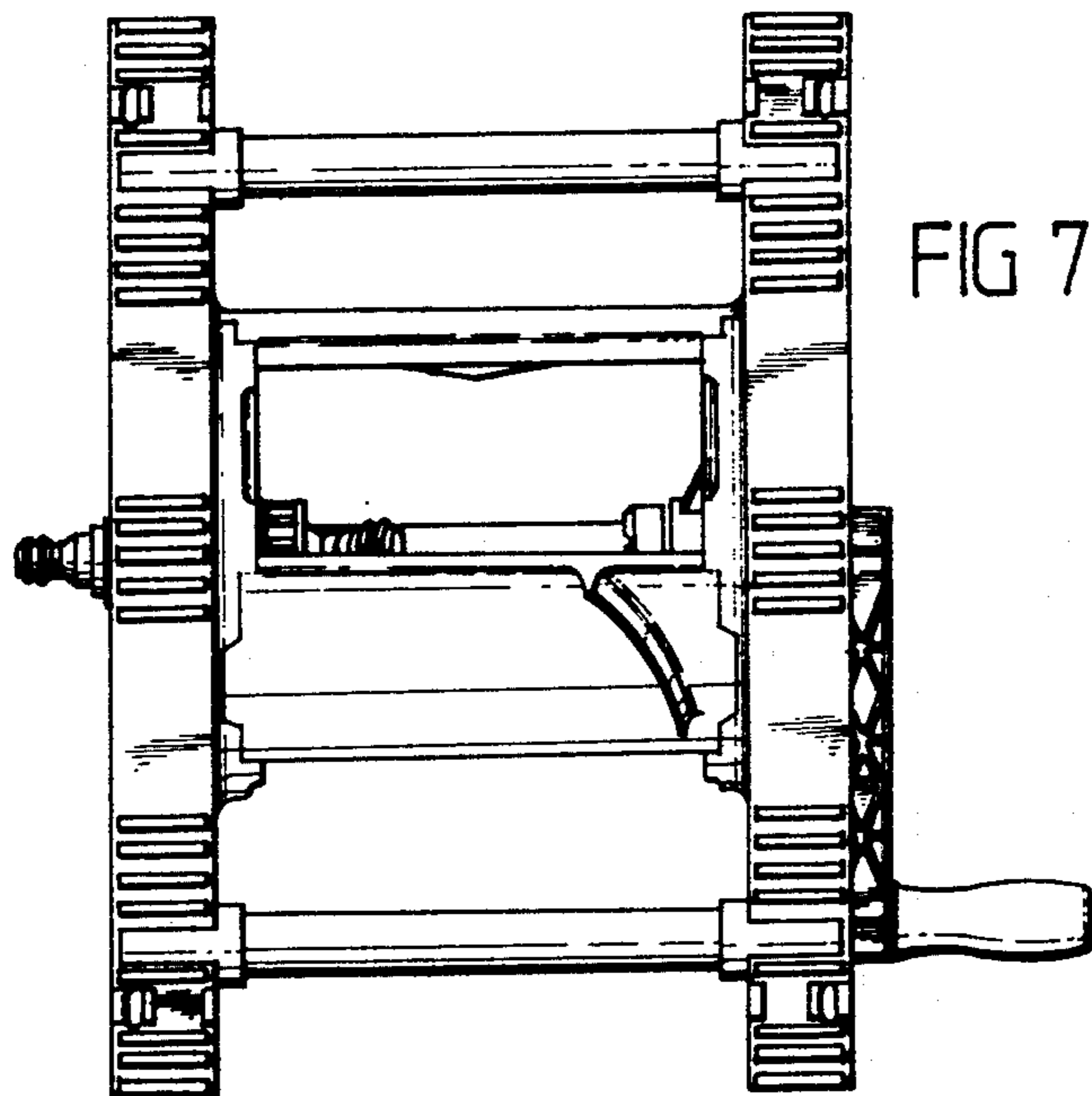

FIG 7