

[54] PRESS BRAKE

[75] Inventor: Kenji Mano, Hatano, Japan

[73] Assignee: Amada Company, Limited, Japan

[**] Term: 14 Years

[21] Appl. No.: 636,854

[22] Filed: Aug. 1, 1984

[52] U.S. Cl. D15/123

[58] Field of Search D15/123; 100/231, 269 R, 100/258 A; 72/316, 318, 319, 389

[56] References Cited

U.S. PATENT DOCUMENTS

- D. 189,560 1/1961 Monschauer D15/123
- 3,633,395 1/1972 Anderson 72/389

- 3,914,975 10/1975 Kawano 100/269 R
- 4,170,124 10/1979 MacGregor 72/389
- 4,220,032 9/1980 Smith 72/389
- 4,455,857 6/1984 Salvagnini D15/123

Primary Examiner—B. J. Bullock
Attorney, Agent, or Firm—Wigman & Cohen

[57] CLAIM

The ornamental design for a press brake, as shown.

DESCRIPTION

- FIG. 1 is a perspective view of the press brake showing my new design;
- FIG. 2 is a front view thereof;
- FIG. 3 is a rear view thereof;
- FIG. 4 is a top view thereof;
- FIG. 5 is a right side view thereof;
- FIG. 6 is a left side view thereof.

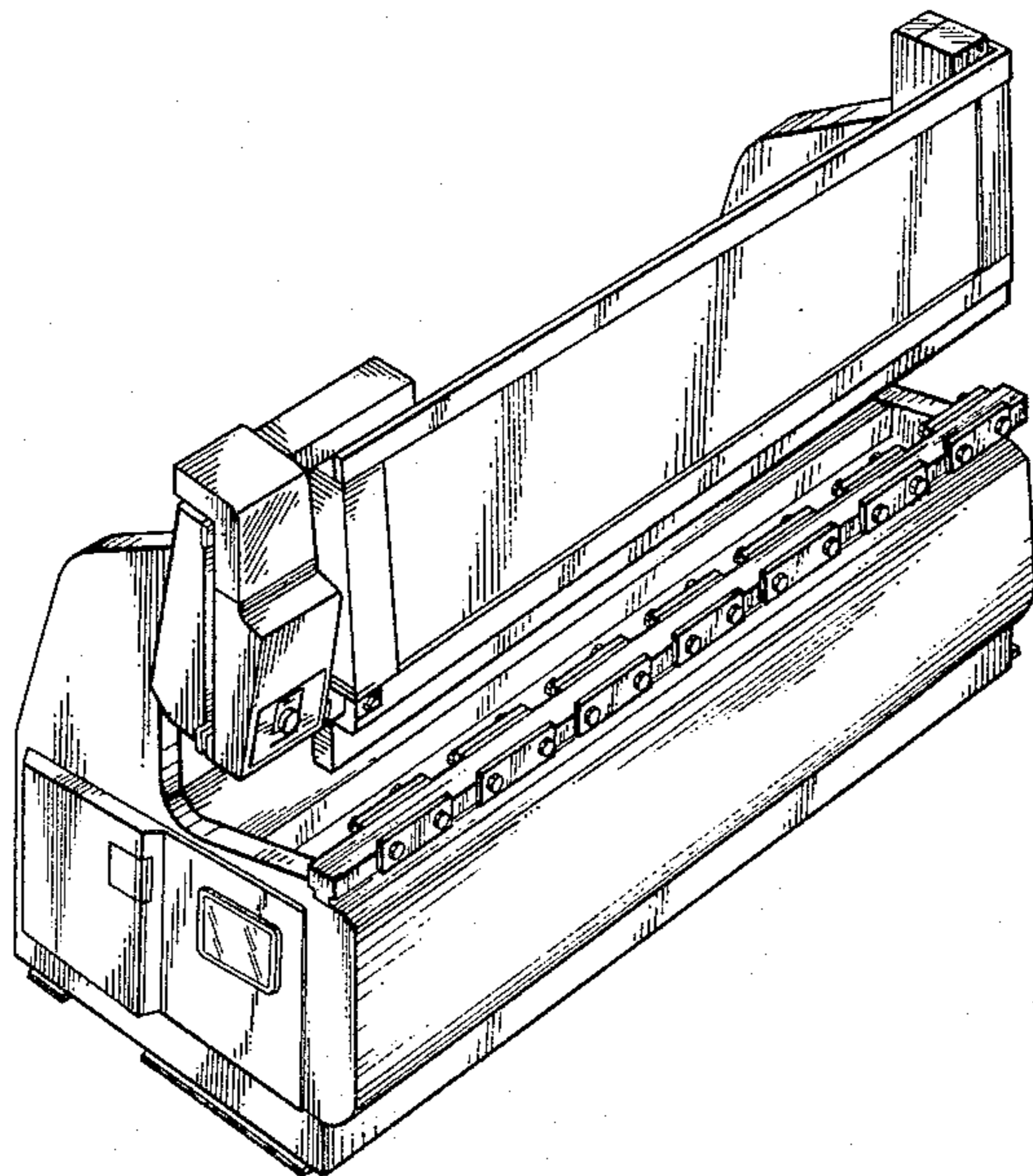

FIG. 1

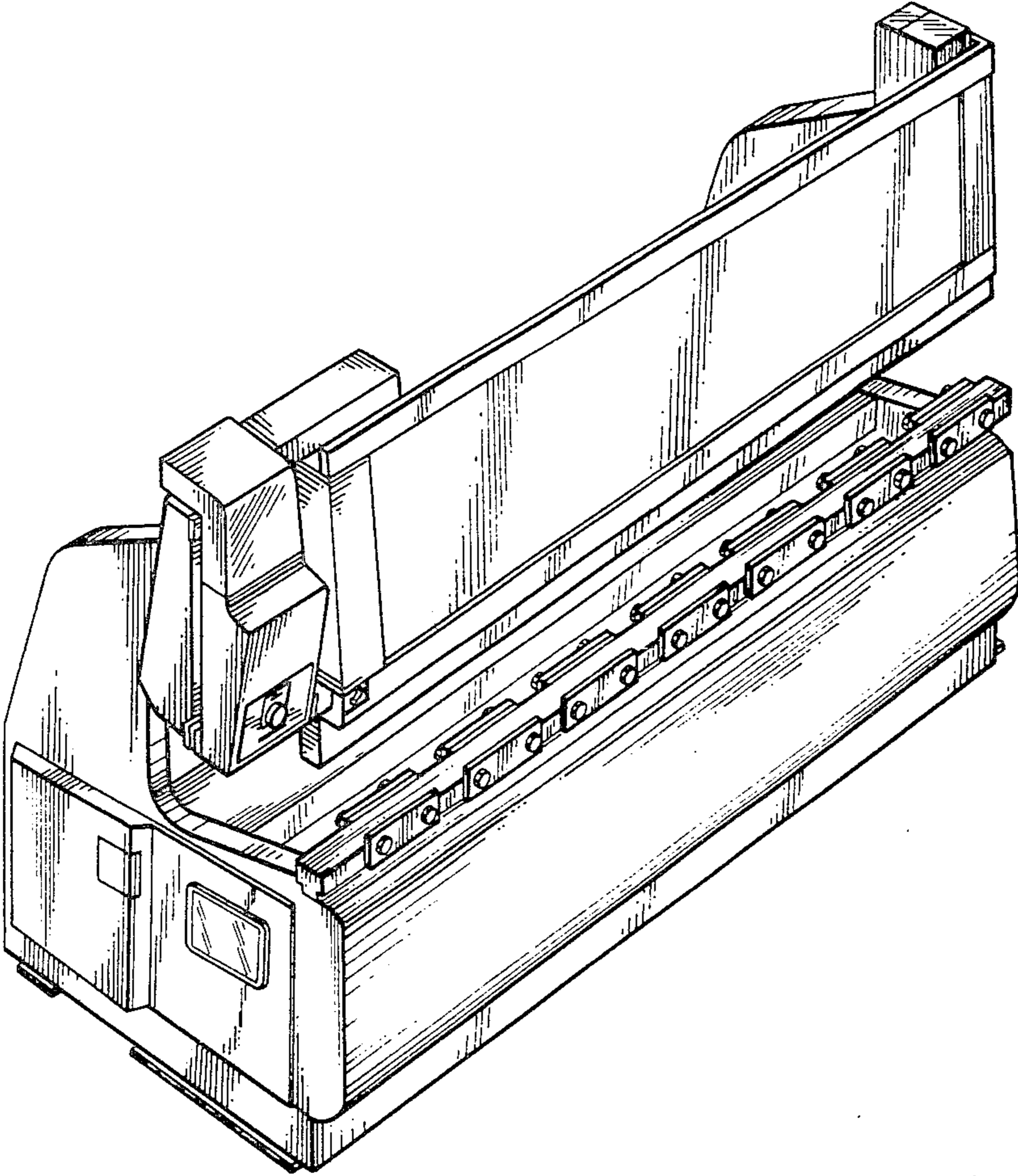

FIG. 2

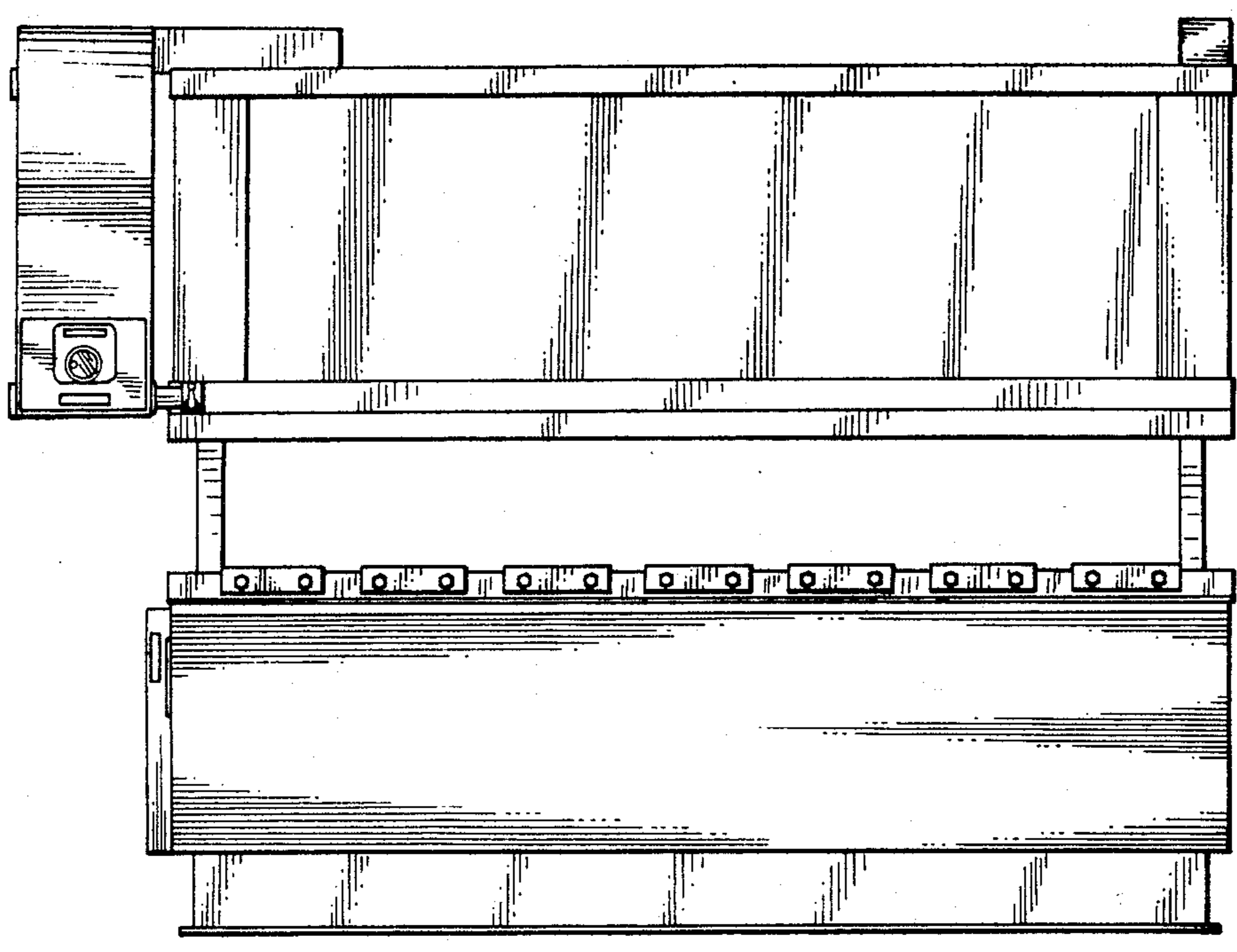

FIG. 3

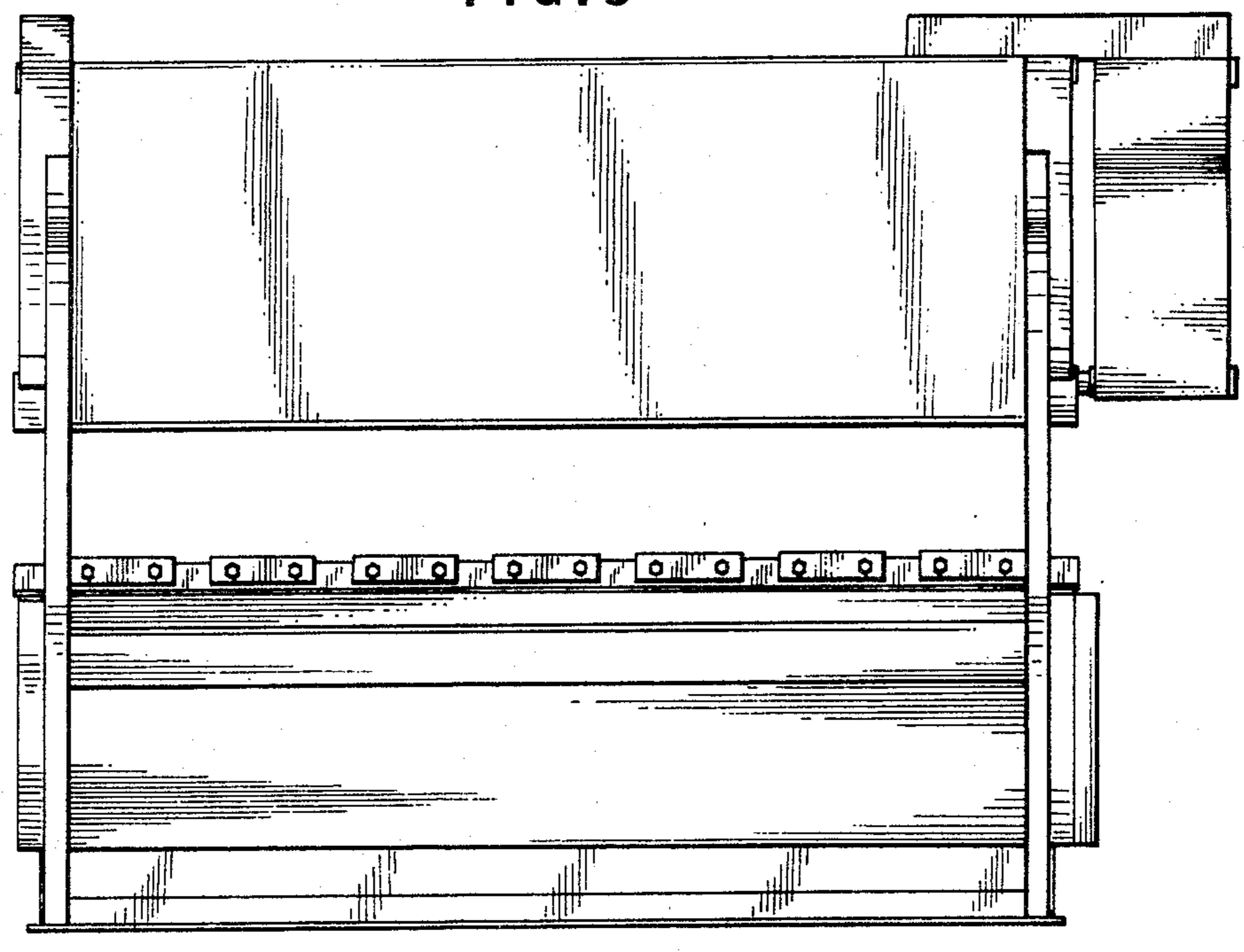

FIG. 4

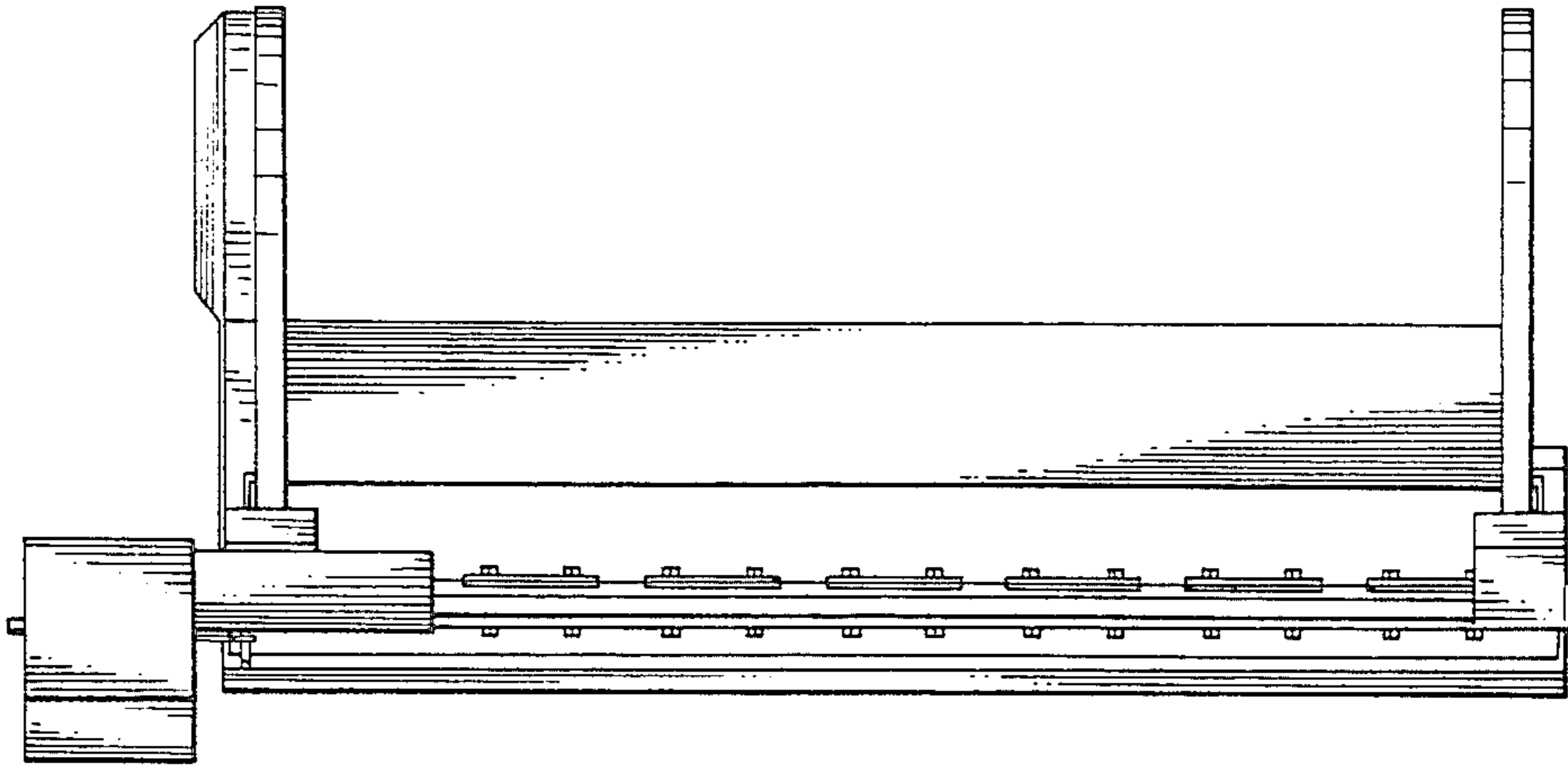

FIG. 5

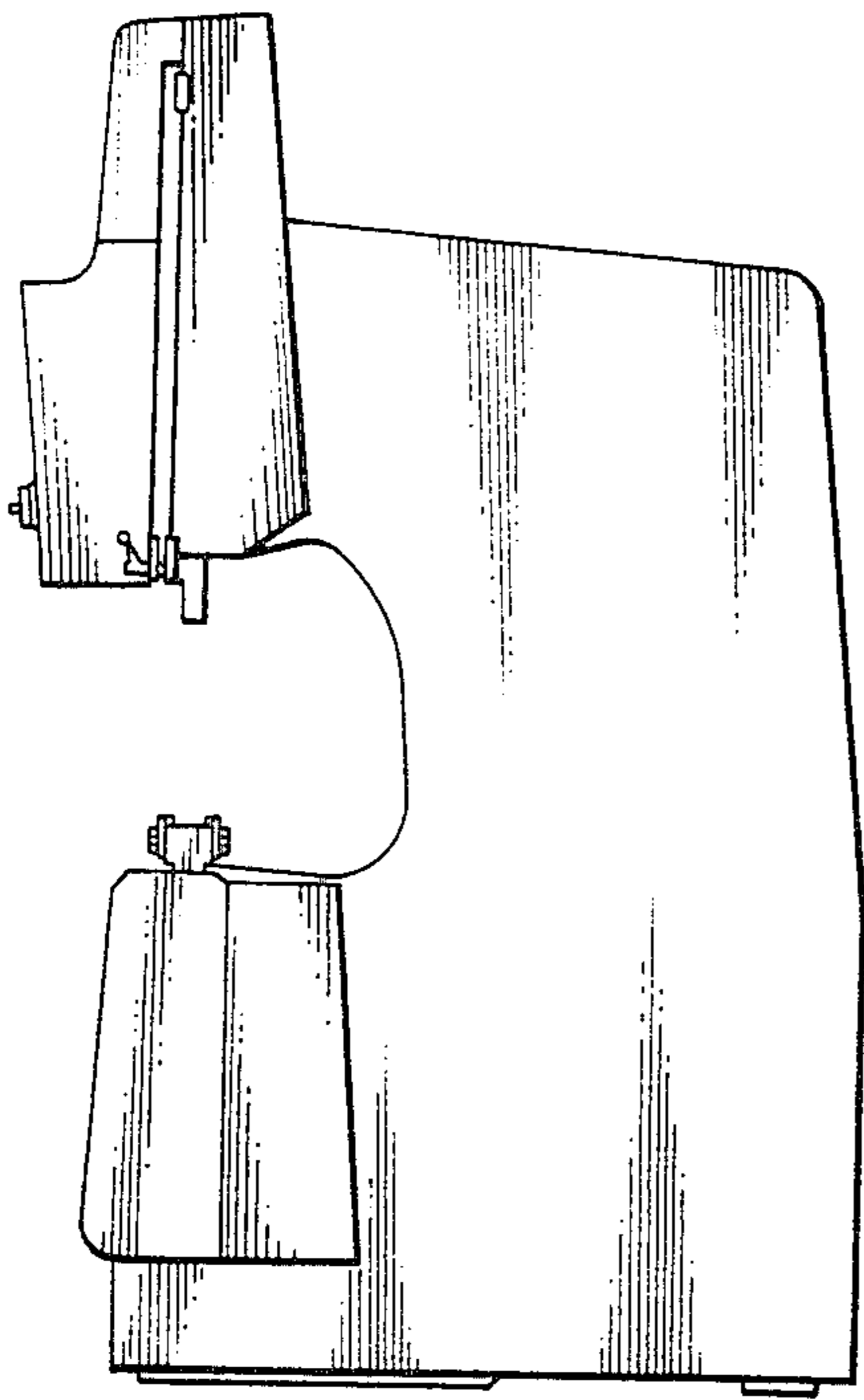

FIG. 6

