

[54] **WHEEL**

[75] **Inventor:** Ulf A. Sandberg, Kungsbacka, Sweden
[73] **Assignee:** Aktiebolaget Volvo, Gothenburg, Sweden
[**] **Term:** 14 Years
[21] **Appl. No.:** 622,284
[22] **Filed:** Jun. 19, 1984
[52] **U.S. Cl.** D12/211
[58] **Field of Search** D12/209-211;
301/63 R, 64 R, 64 SD, 65

[56] **References Cited**
U.S. PATENT DOCUMENTS
D. 245,599 8/1977 de Vries D12/211

OTHER PUBLICATIONS

Road & Track, 1/84, p. 29, Pontial 6000-STE Wheel, lower center of page.

Primary Examiner—James M. Gandy
Attorney, Agent, or Firm—Young & Thompson

[57] **CLAIM**

The ornamental design for a wheel, as shown and described.

DESCRIPTION

FIG. 1 is a front and side perspective view of a wheel showing my new design;
FIG. 2 is an end elevation view thereof;
FIG. 3 is a front perspective view thereof, taken slightly from above;
FIG. 4 is a rear perspective view thereof, taken slightly from above.

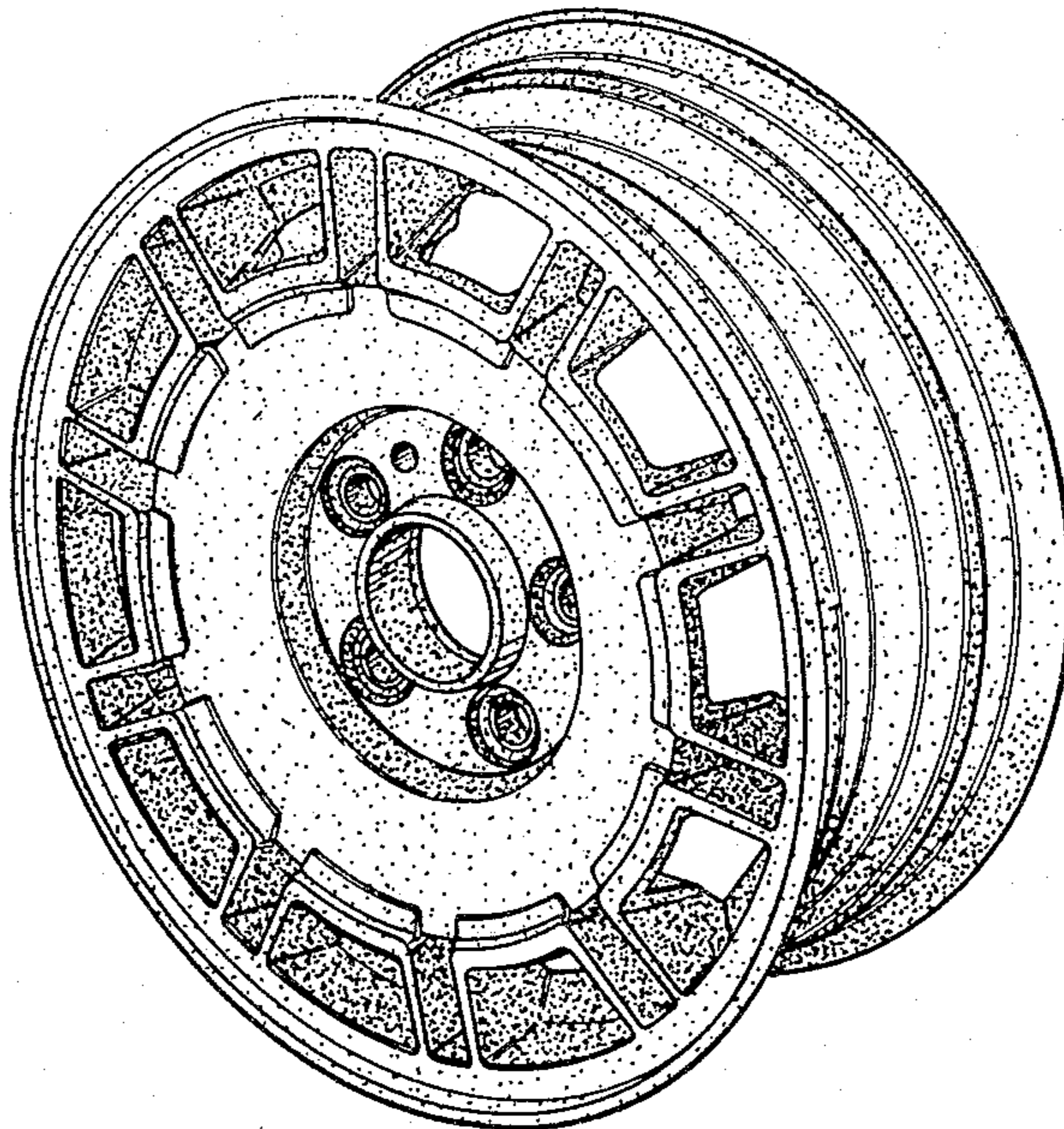

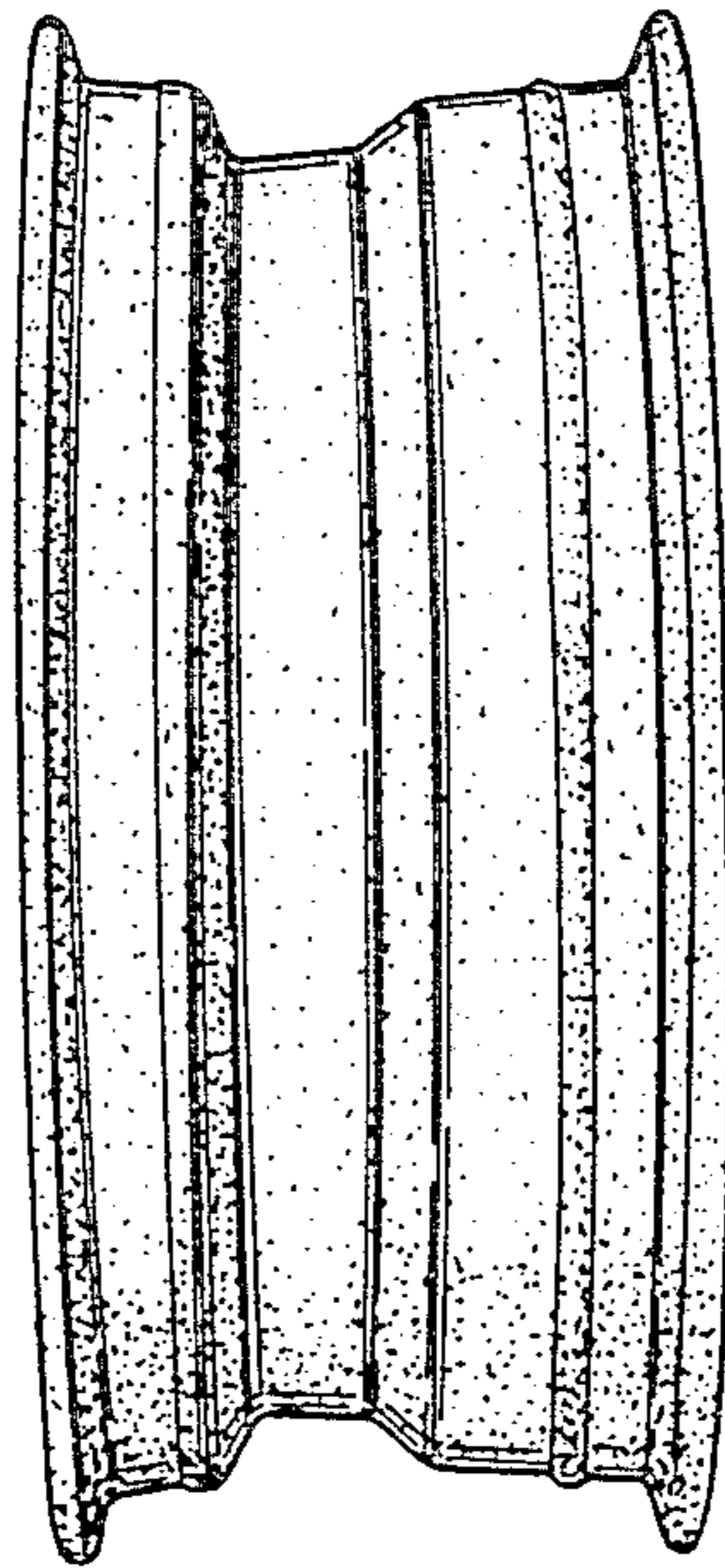
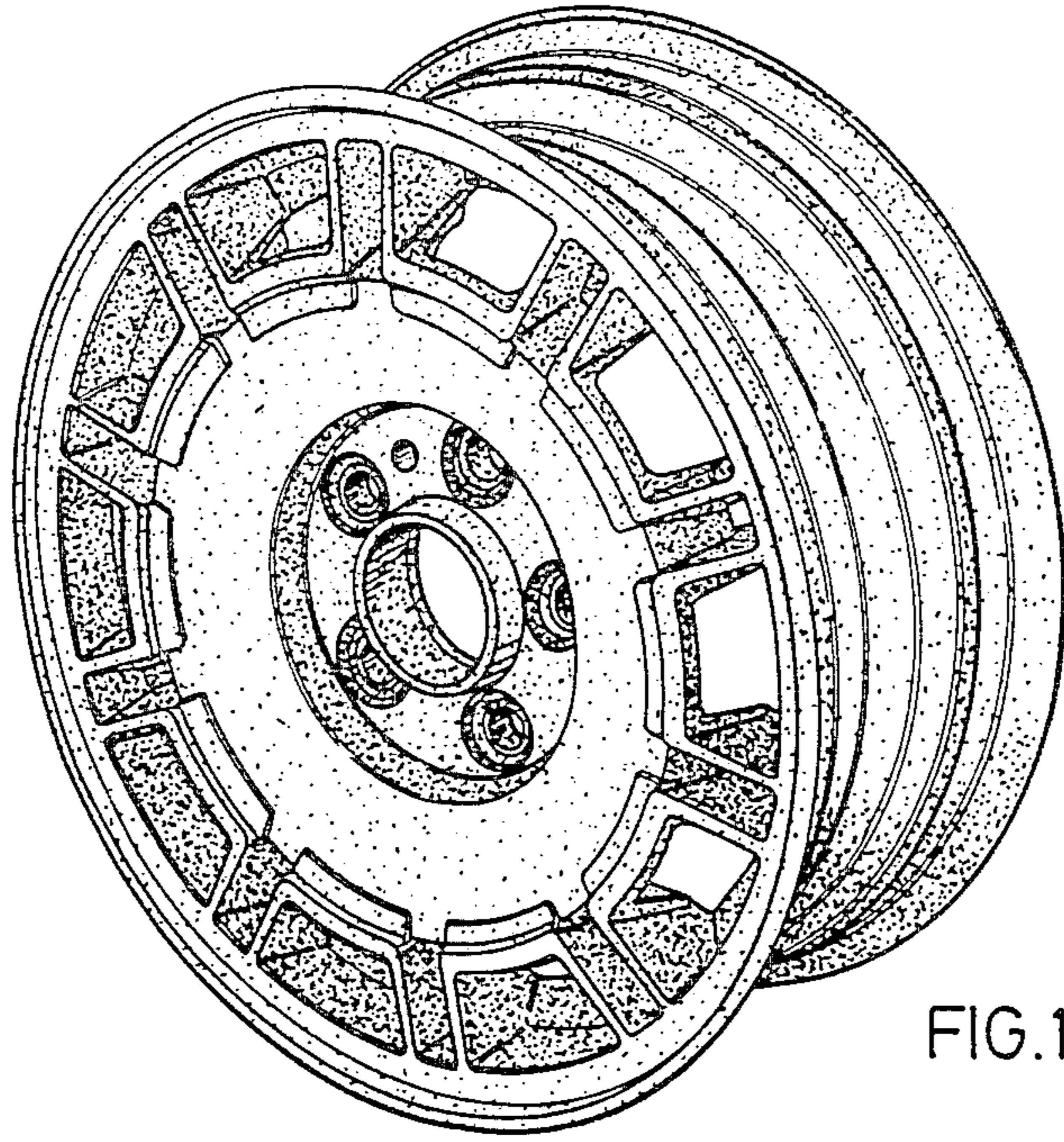

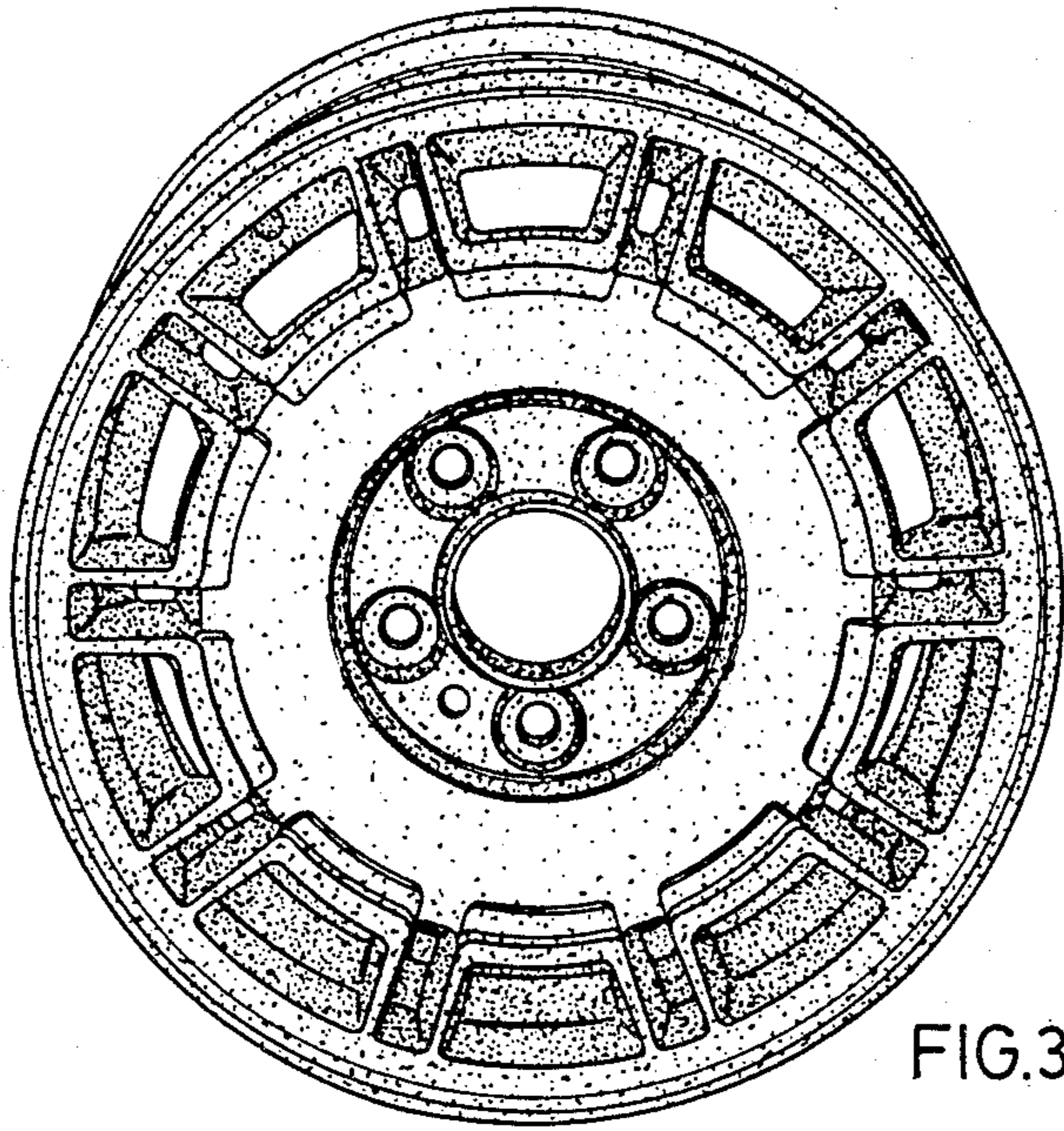

FIG. 3

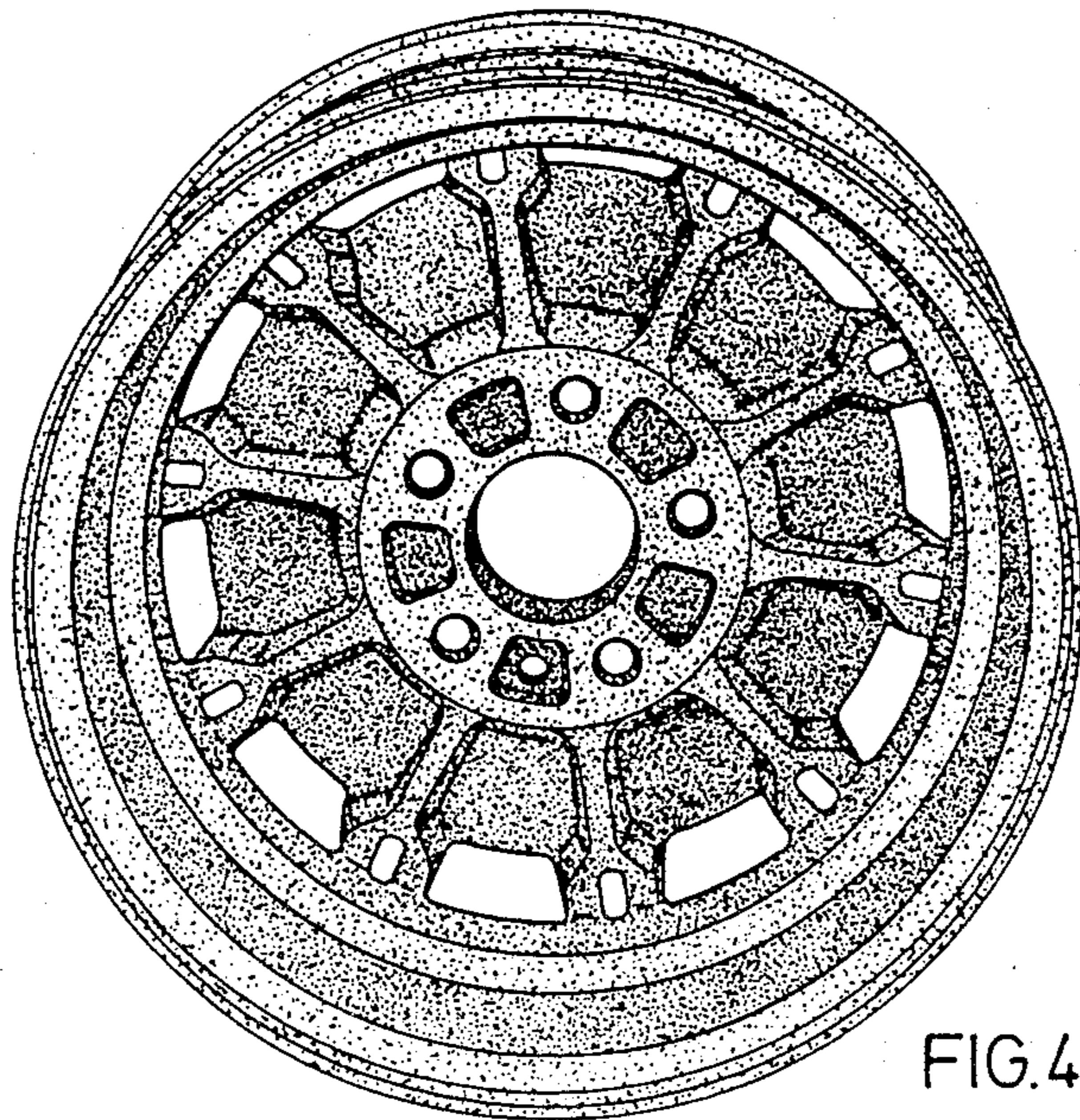

FIG. 4