

[54] RADIO RECEIVER

[75] Inventors: John Stoddard; Clive Grinyer, both of London, England

[73] Assignees: Ford Motor Company, Dearborn, Mich.

[**] Term: 14 Years

[21] Appl. No.: 636,049

[22] Filed: Jul. 30, 1984

[52] U.S. Cl. D14/68; D14/1

[58] Field of Search D14/68, 69, 70, 71, D14/72, 73, 74, 75, 76, 99, 5, 1; 455/344, 345, 346, 347, 350, 351, 349

[56] References Cited

U.S. PATENT DOCUMENTS

- D. 261,136 10/1981 Yamada et al. D14/5
- D. 278,430 4/1985 Van De Poel D14/5
- D. 284,283 6/1986 Van De Ven D14/68
- 4,481,512 11/1984 Tscheulin et al. 455/349 X

OTHER PUBLICATIONS

Merchandising, Apr. 1983, p. 22, Sparkomatic SR 308.
Best Products Catalog 1983/84, p. 371, Item #2, Craig Stereo Cassette Model T 103.

Primary Examiner—Bernard Ansher
Assistant Examiner—Theodore M. Shooman
Attorney, Agent, or Firm—Paul K. Godwin, Jr.; Clifford L. Sadler

[57] CLAIM

The ornamental design for a radio receiver, as shown and described.

DESCRIPTION

FIG. 1 is a front, top and right side perspective view of a radio receiver showing our new design;
 FIG. 2 is a top plan view thereof;
 FIG. 3 is a front elevational view thereof;
 FIG. 4 is a bottom plan view thereof;
 FIG. 5 is a left side elevational view thereof;
 FIG. 6 is a right side elevational view thereof;
 FIG. 7 is a front, top and right side perspective view of a second embodiment of the radio receiver illustrated in FIG. 1;
 FIG. 8 is a top plan view of the embodiment disclosed in FIG. 7;
 FIG. 9 is a front elevational view of the embodiment disclosed in FIG. 7;
 FIG. 10 is a bottom plan view of the embodiment disclosed in FIG. 7;
 FIG. 11 is a left side elevational view of the embodiment disclosed in FIG. 7; and
 FIG. 12 is a right side elevational view of the embodiment disclosed in FIG. 7.

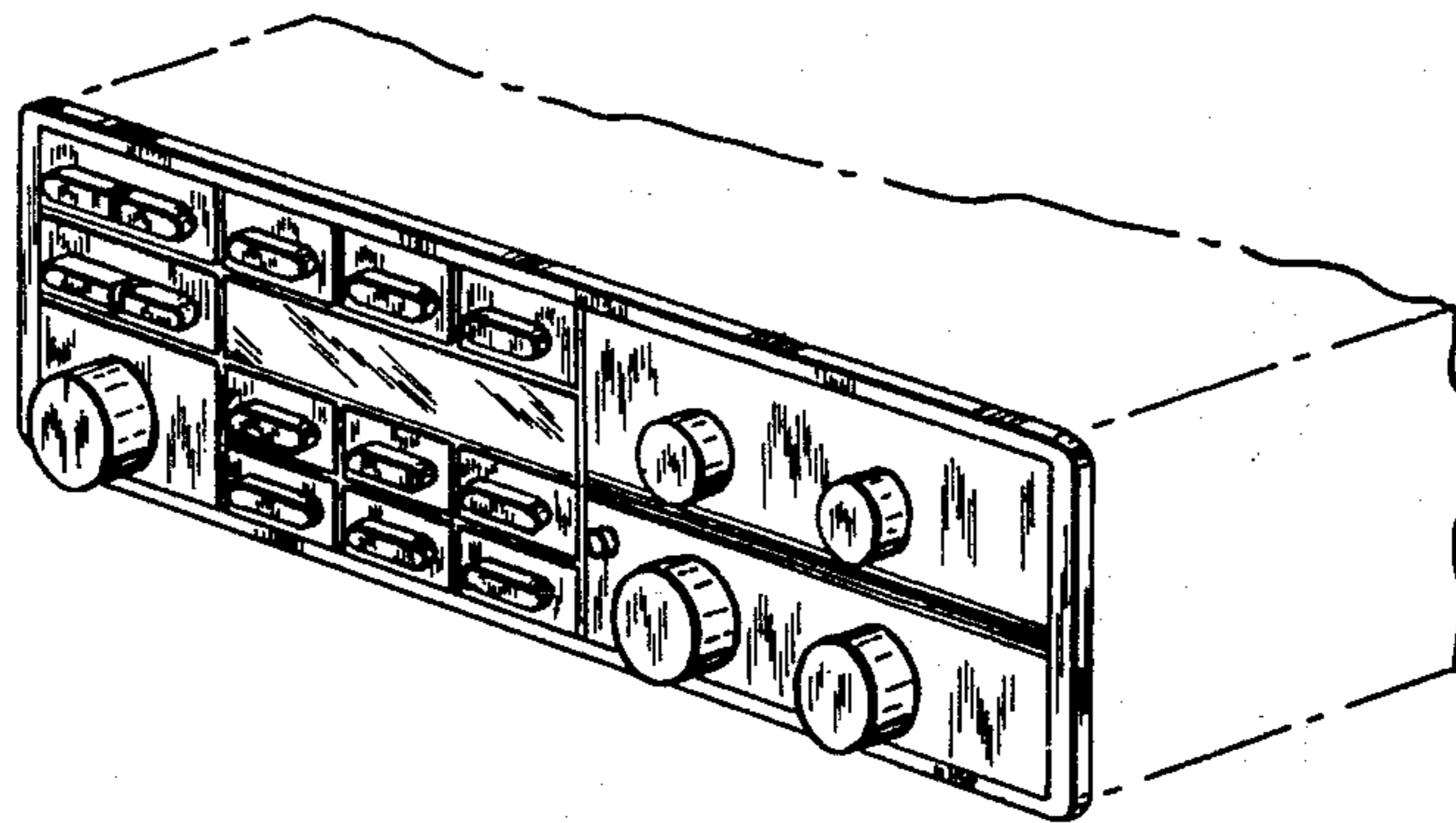

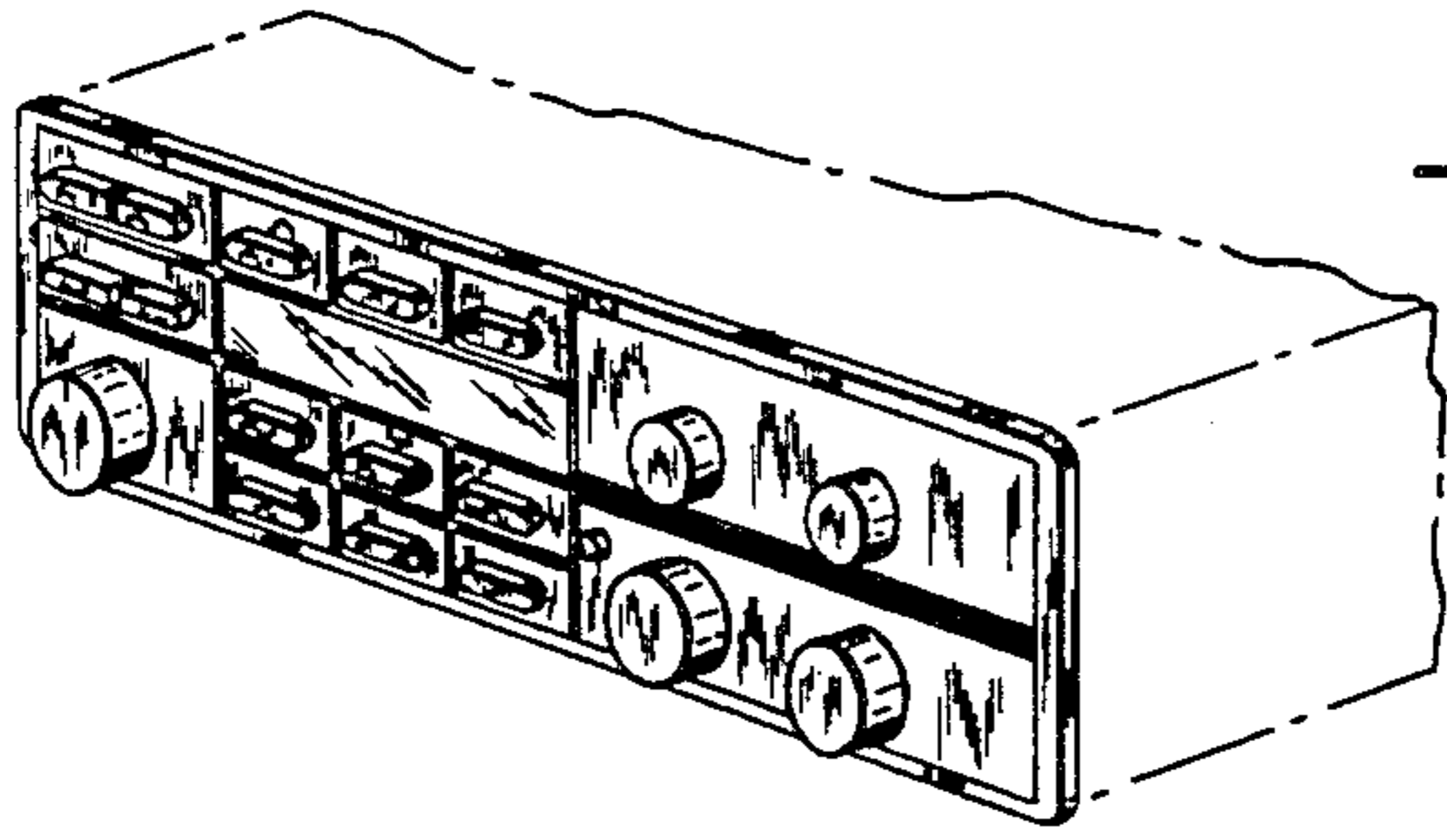

FIG. 1.

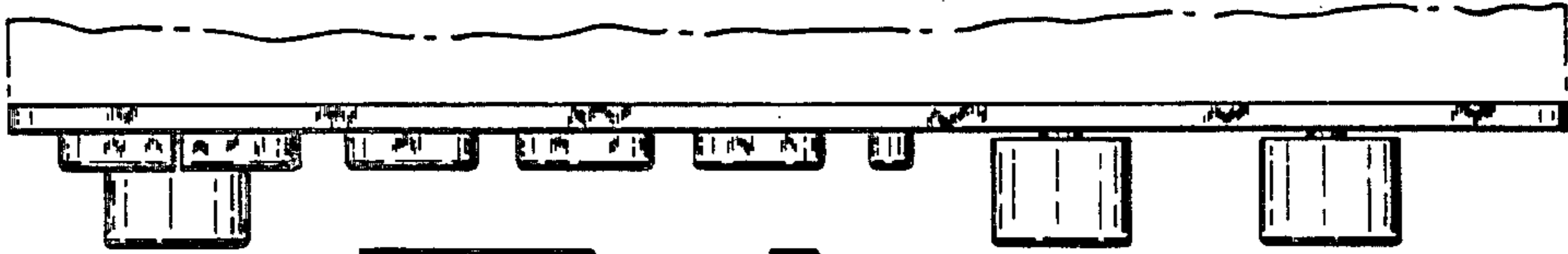

FIG. 2.

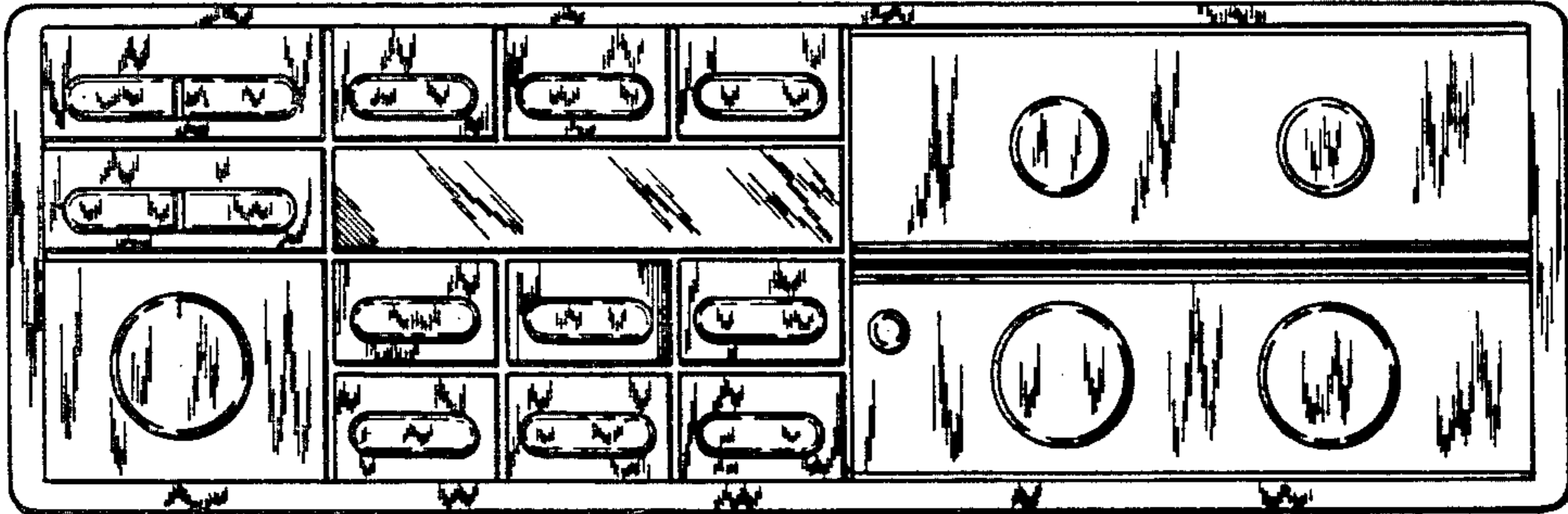

FIG. 3.

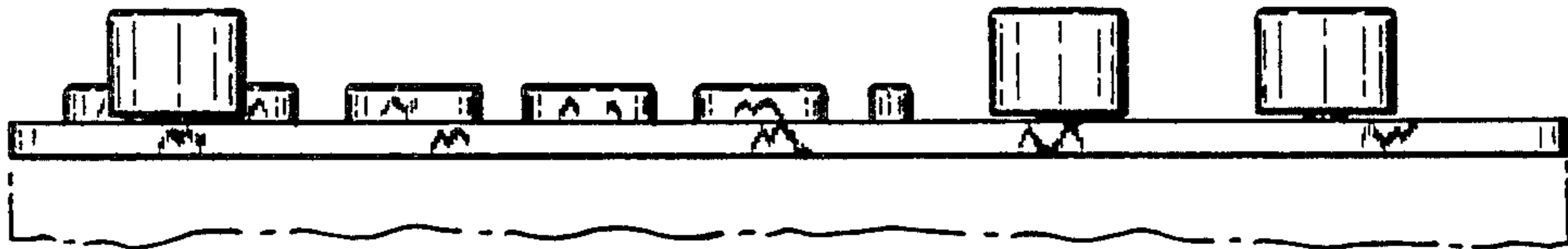

FIG. 4.

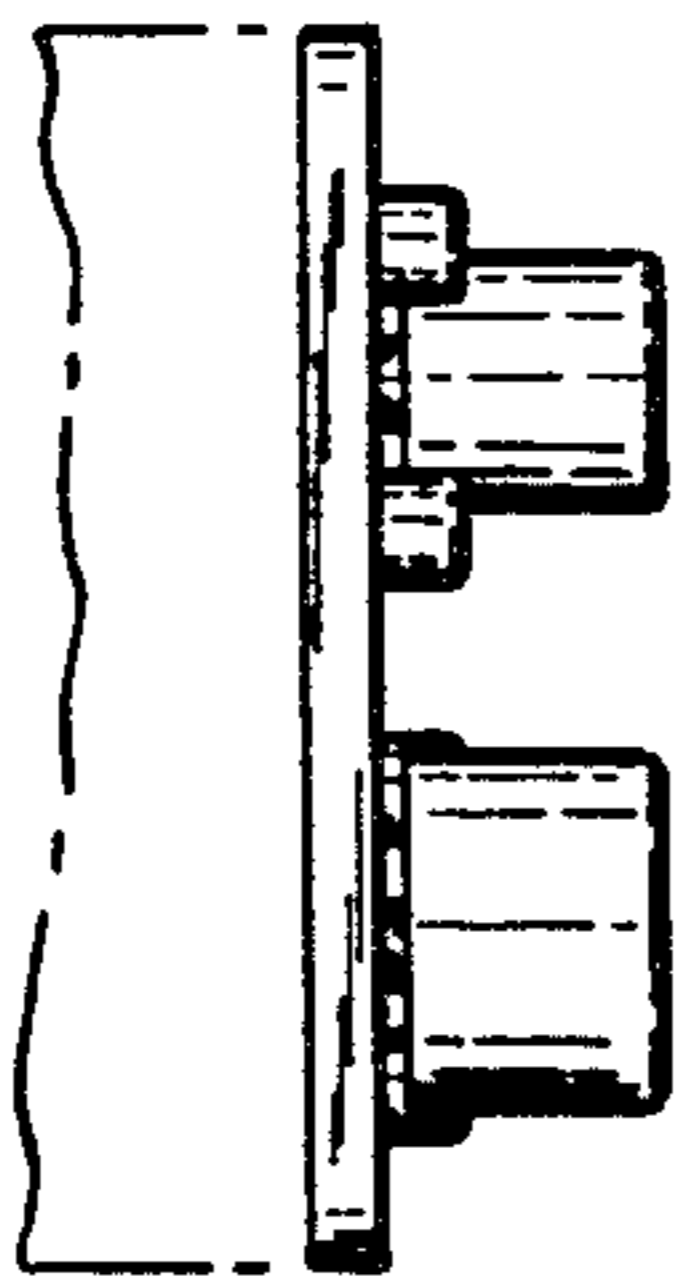

FIG. 5.

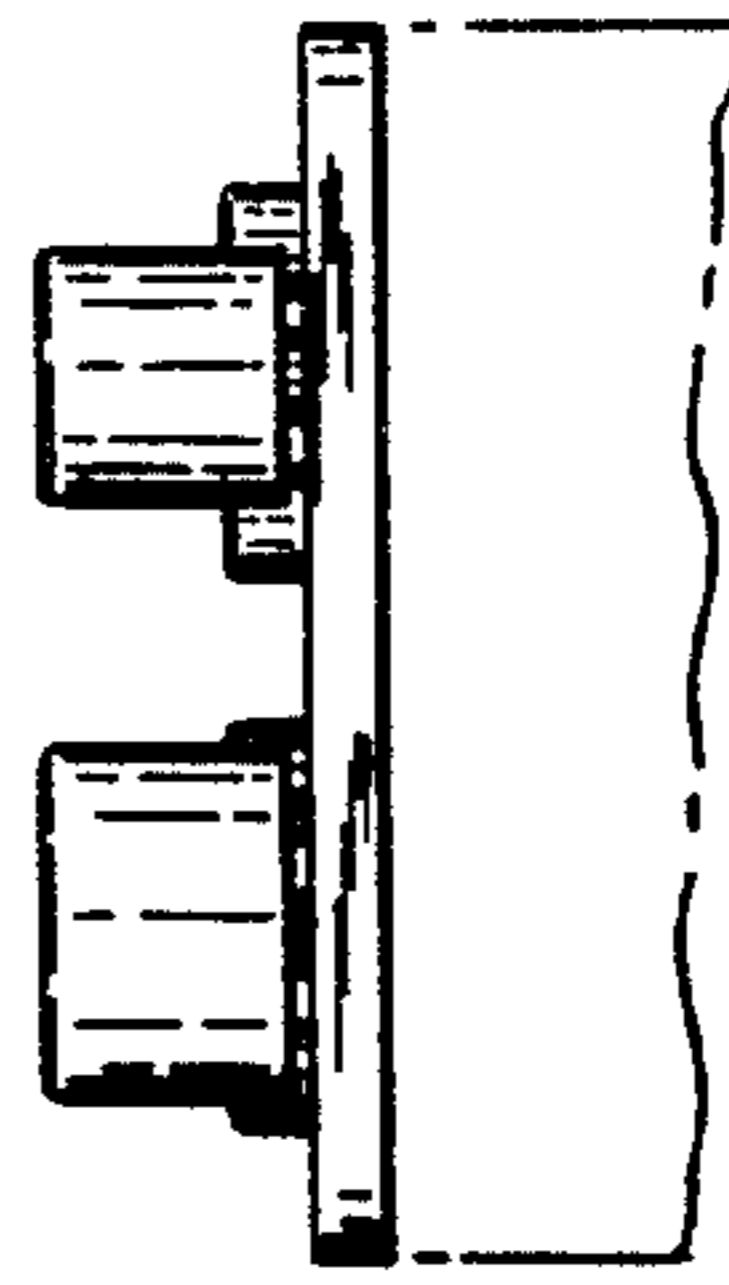

FIG. 6.

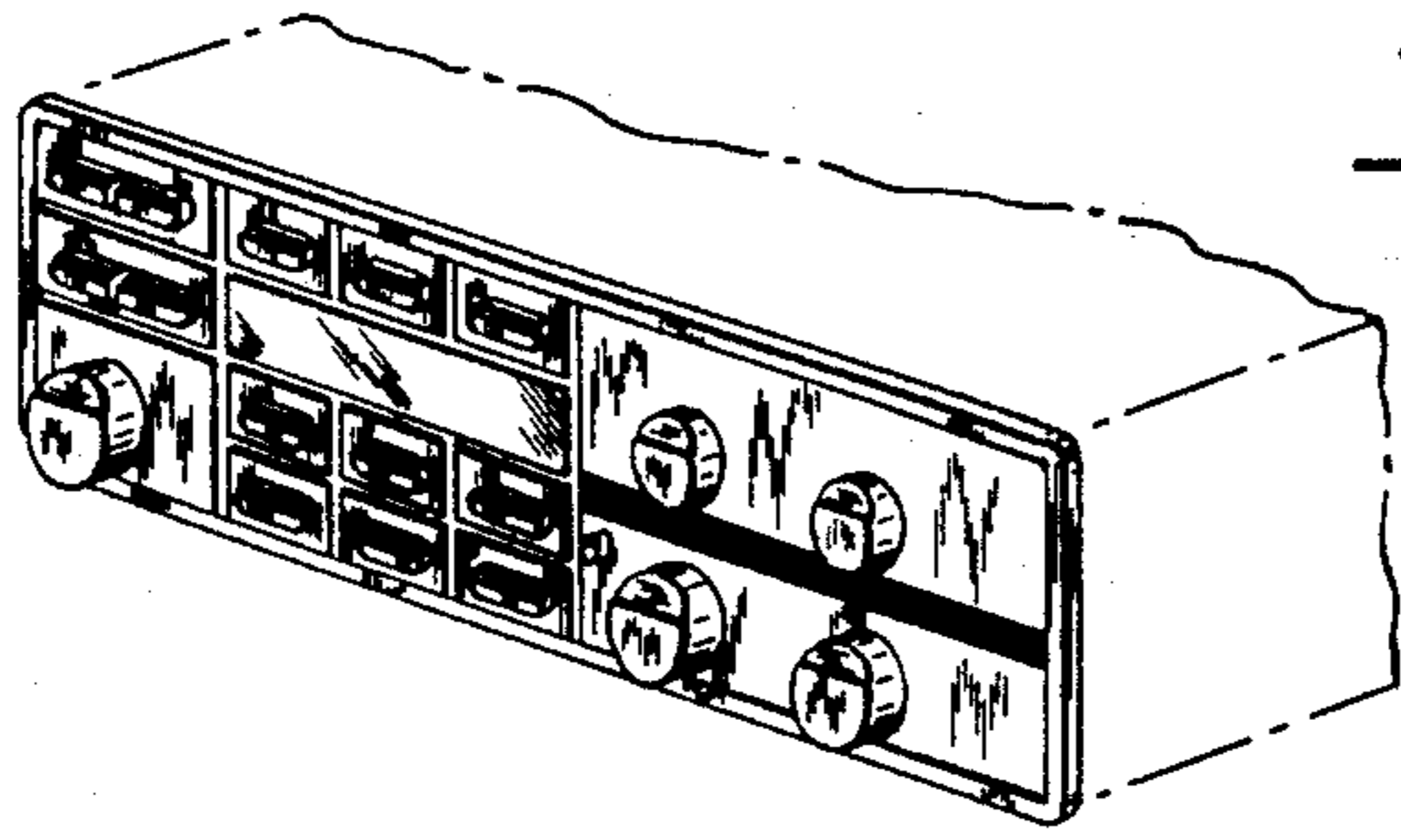

Fig. 7.

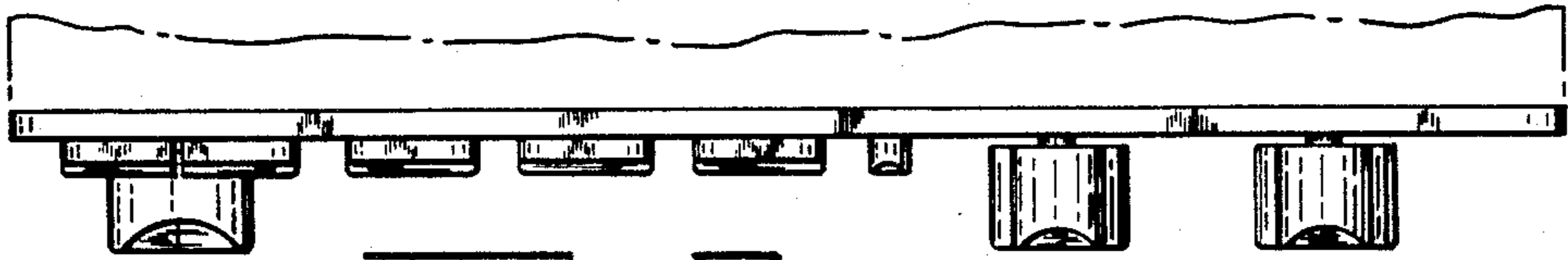

Fig. 8.

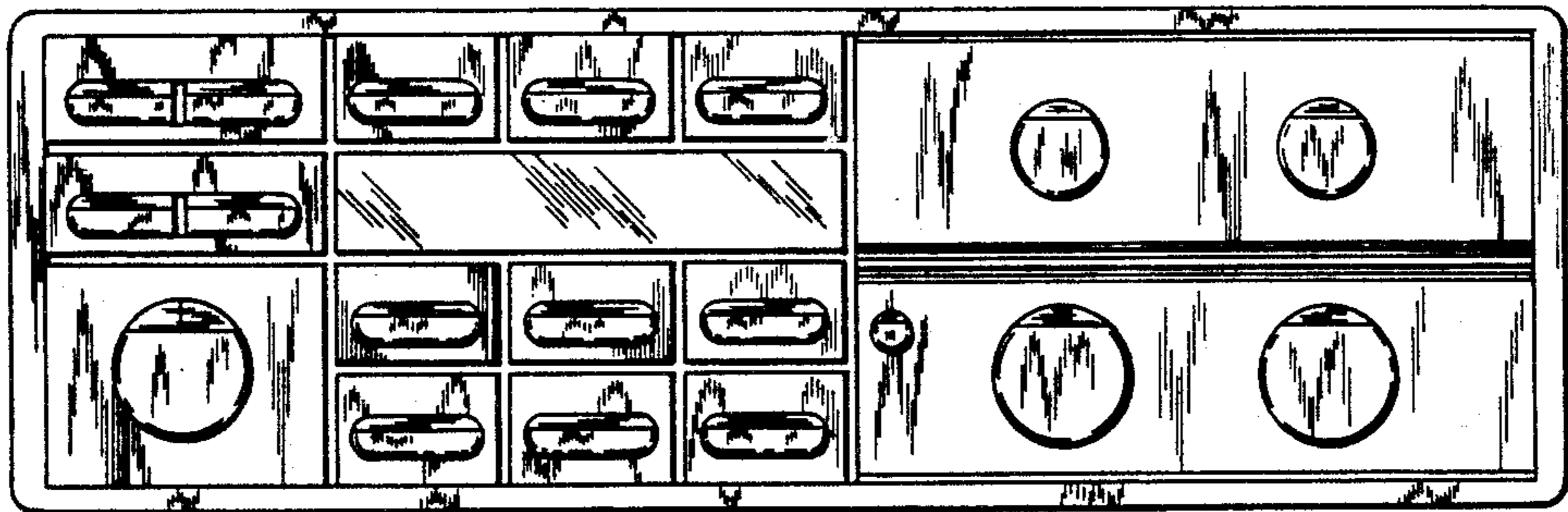

Fig. 9.

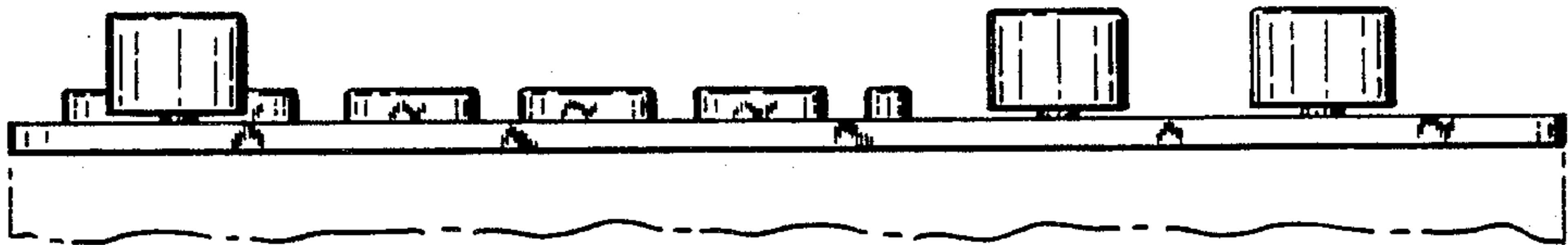

Fig. 10.

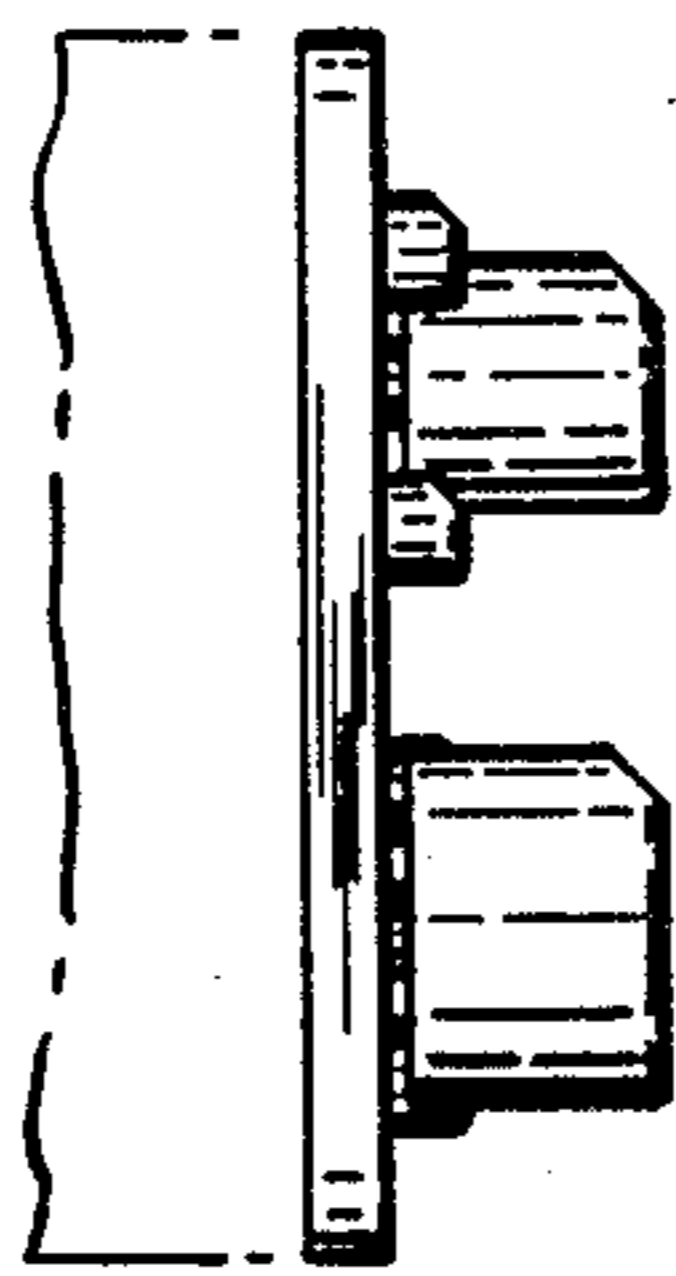

Fig. 11.

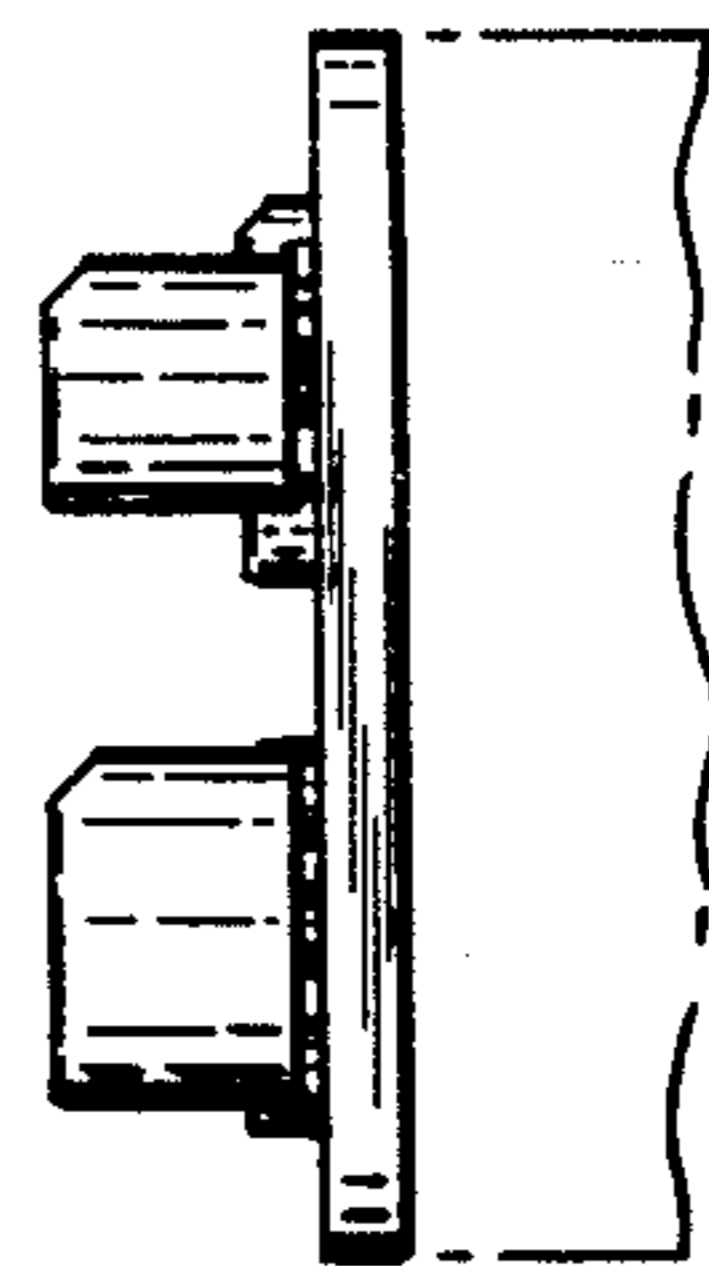

Fig. 12.