

[54] FRONT BUMPER

[75] Inventors: Tadao Okumura, Toyota, Japan
[73] Assignee: Toyota Jidosha Kabushiki Kaisha, Toyota, Japan

[**] Term: 14 Years

[21] Appl. No.: 606,680

[22] Filed: May 3, 1984

[52] U.S. Cl. D12/169

[58] Field of Search D12/169; 293/120, 121, 293/136

Road & Track, 11/82, p. 192, Front Bumper of Toyota SR5, lower center of page.

Road & Track, 2/83, p. 51, Toyota Cressida Front Bumper, top of page.

Road & Track, 4/83, p. 120, Renault Alliance Front Bumper, top of page.

Primary Examiner—James M. Gandy
Attorney, Agent, or Firm—Cushman, Darby & Cushman

[57] CLAIM

The ornamental design for a front bumper, as shown and described.

DESCRIPTION

FIG. 1 is a front perspective view of a front bumper showing my new design;

FIG. 2 is a front elevational view;

FIG. 3 is a rear elevational view;

FIG. 4 is a top plan view;

FIG. 5 is a bottom plan view;

FIG. 6 is a right side elevational view;

FIG. 7 is a sectional view taken along line VII—VII in FIG. 2; and

FIG. 8 is a front perspective view thereof, it being understood that the broken lines are for illustrative purposes only.

[56] References Cited

U.S. PATENT DOCUMENTS

D. 248,156 6/1978 Tixier D12/169
D. 281,872 12/1985 Teague et al. D12/169

FOREIGN PATENT DOCUMENTS

638607 8/1984 Japan .

OTHER PUBLICATIONS

Motor Trend, 3/81, p. 19, Front Bumper of Toyota EX-8, center left side of page.

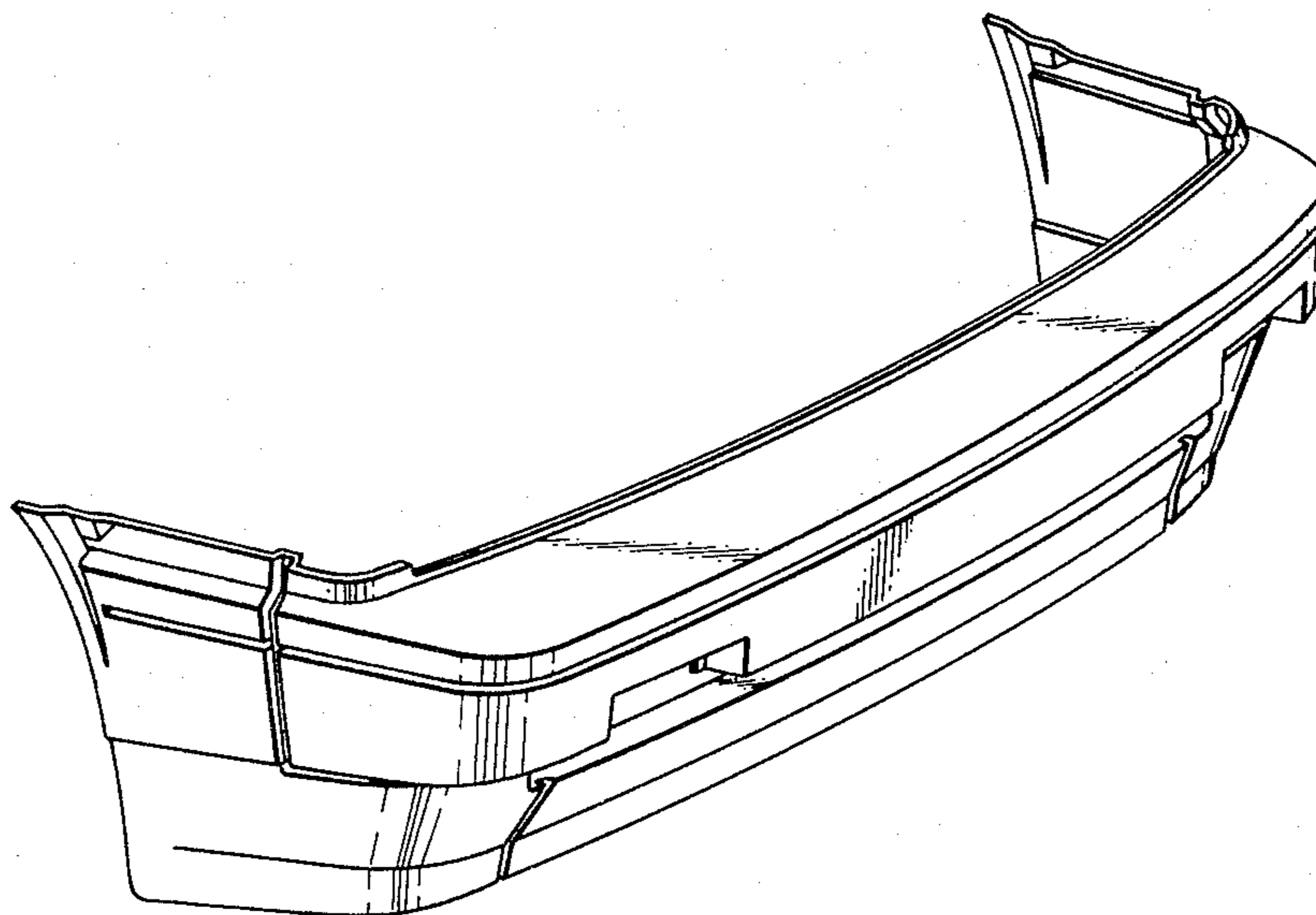

Fig. 1

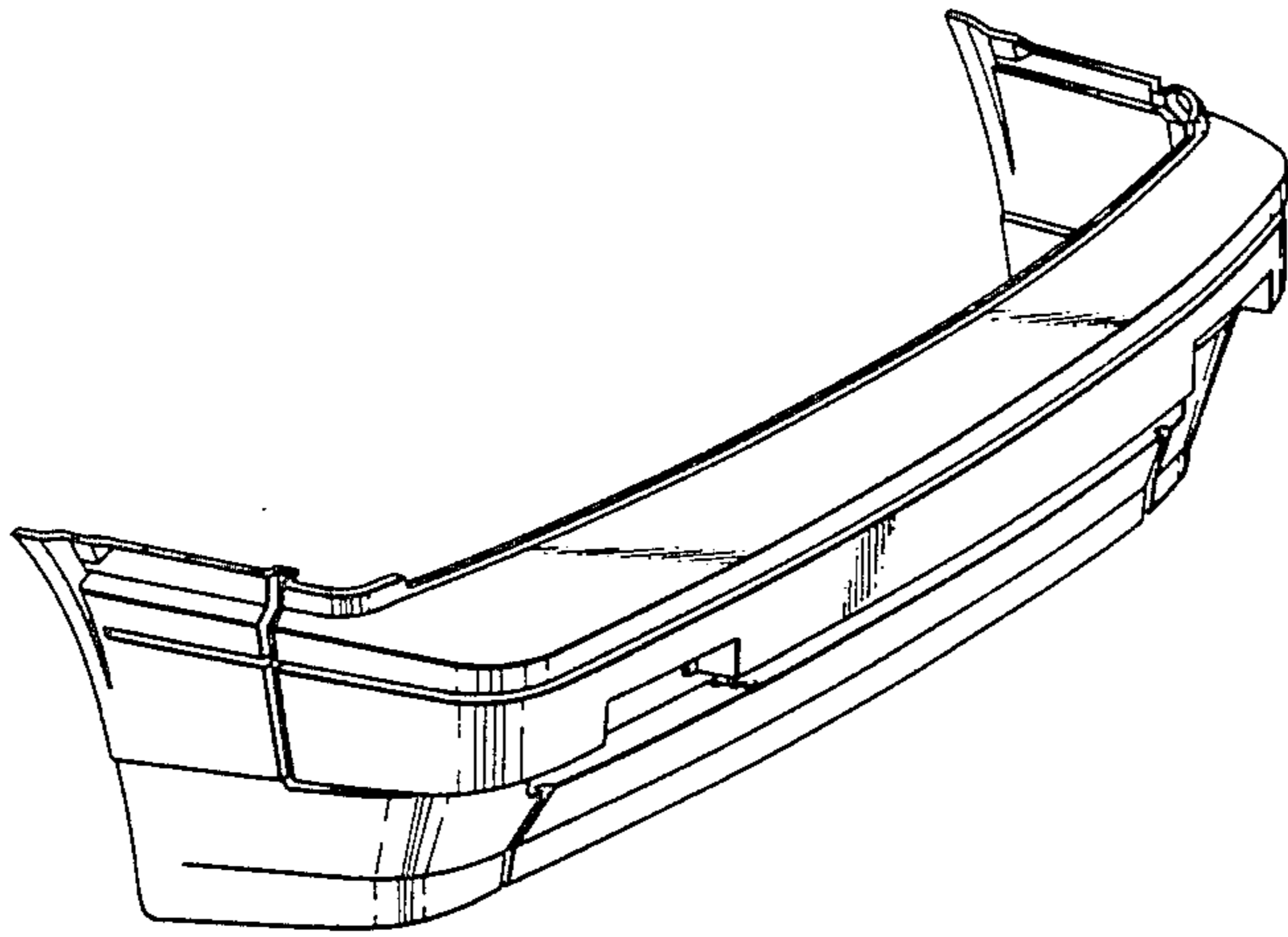

Fig. 2

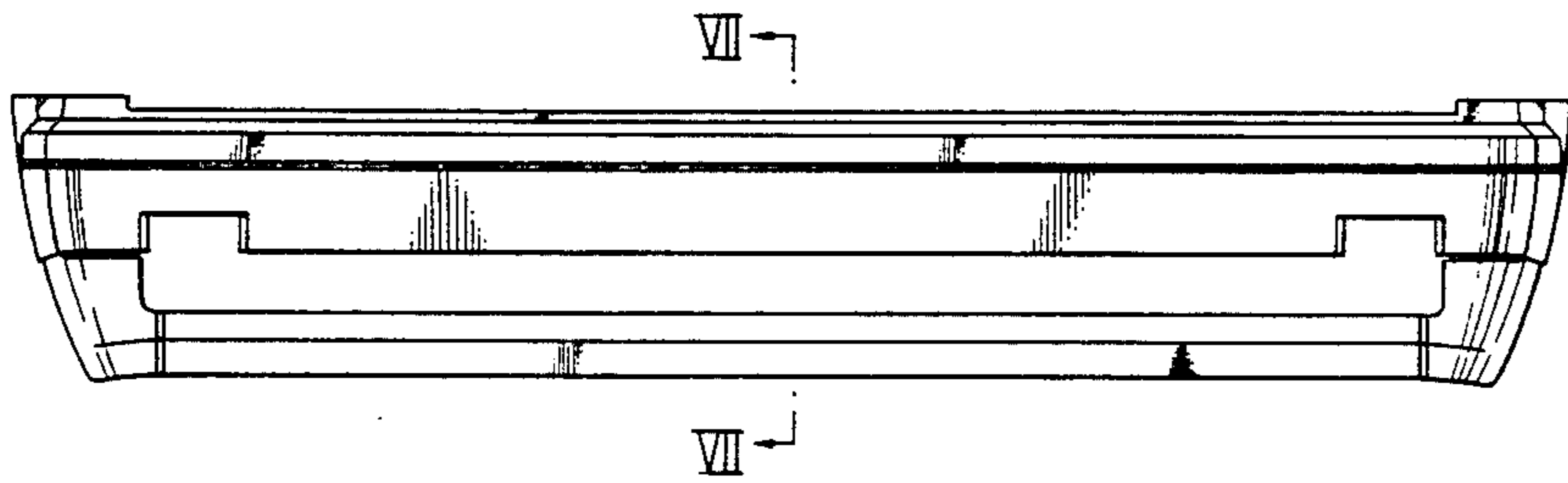

Fig. 3

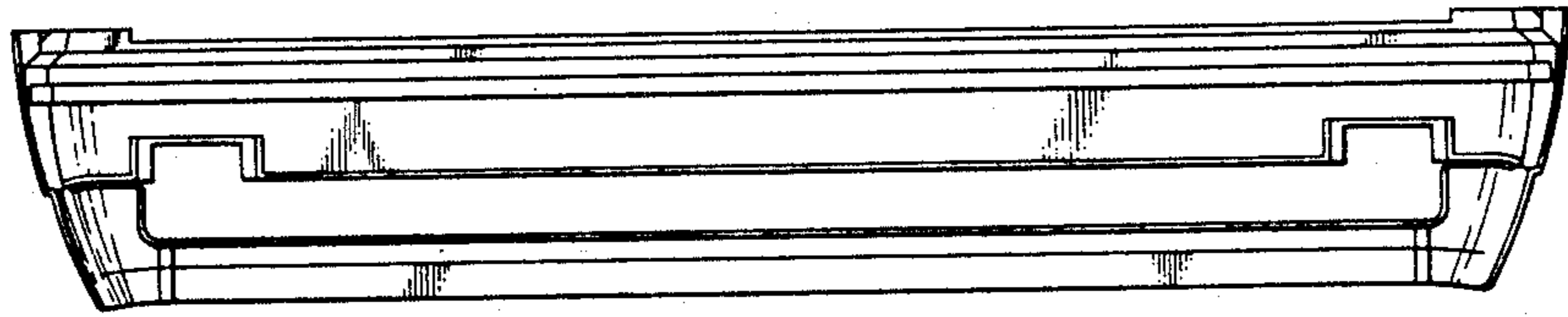

Fig. 4

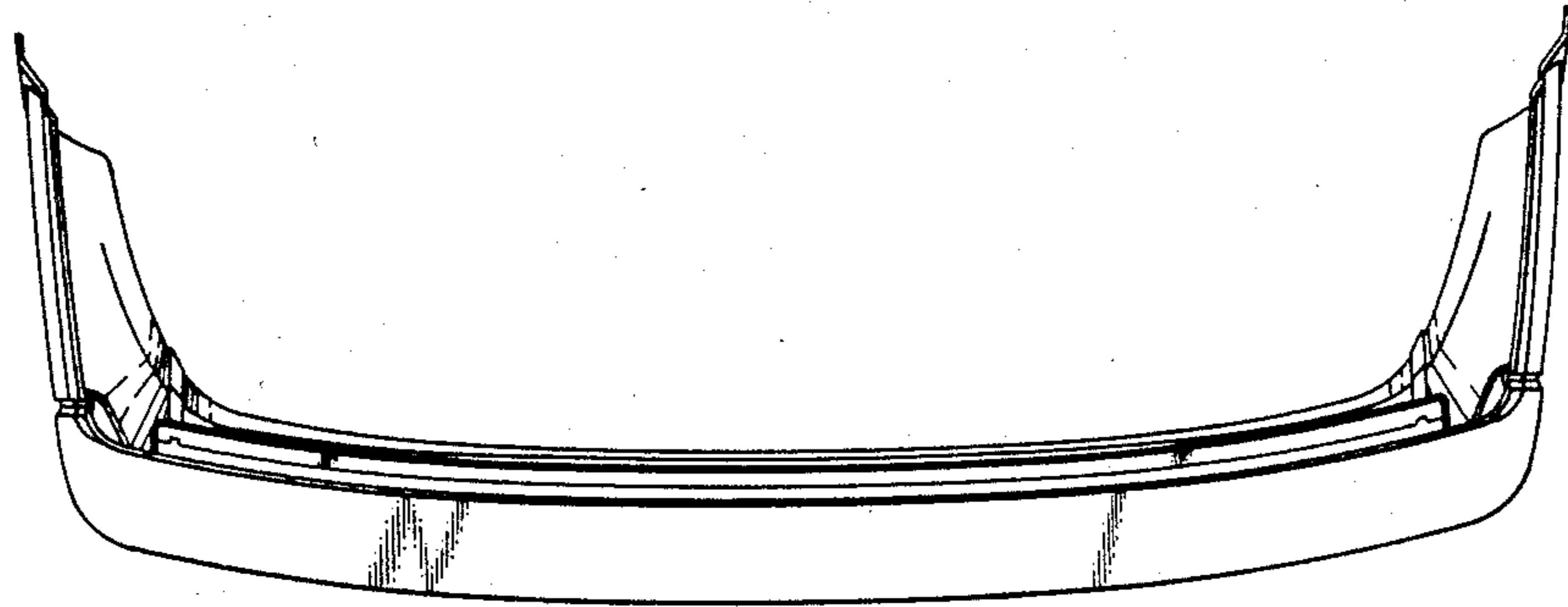

Fig. 5

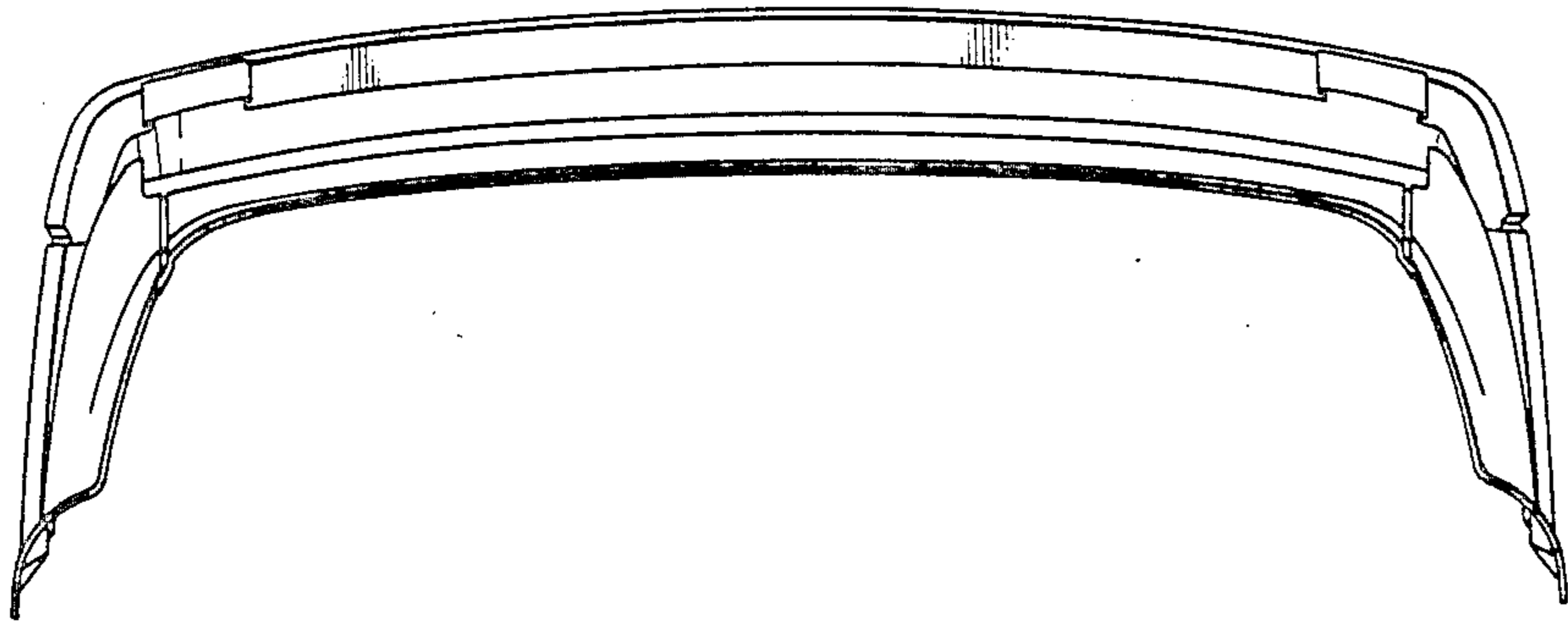

Fig. 6

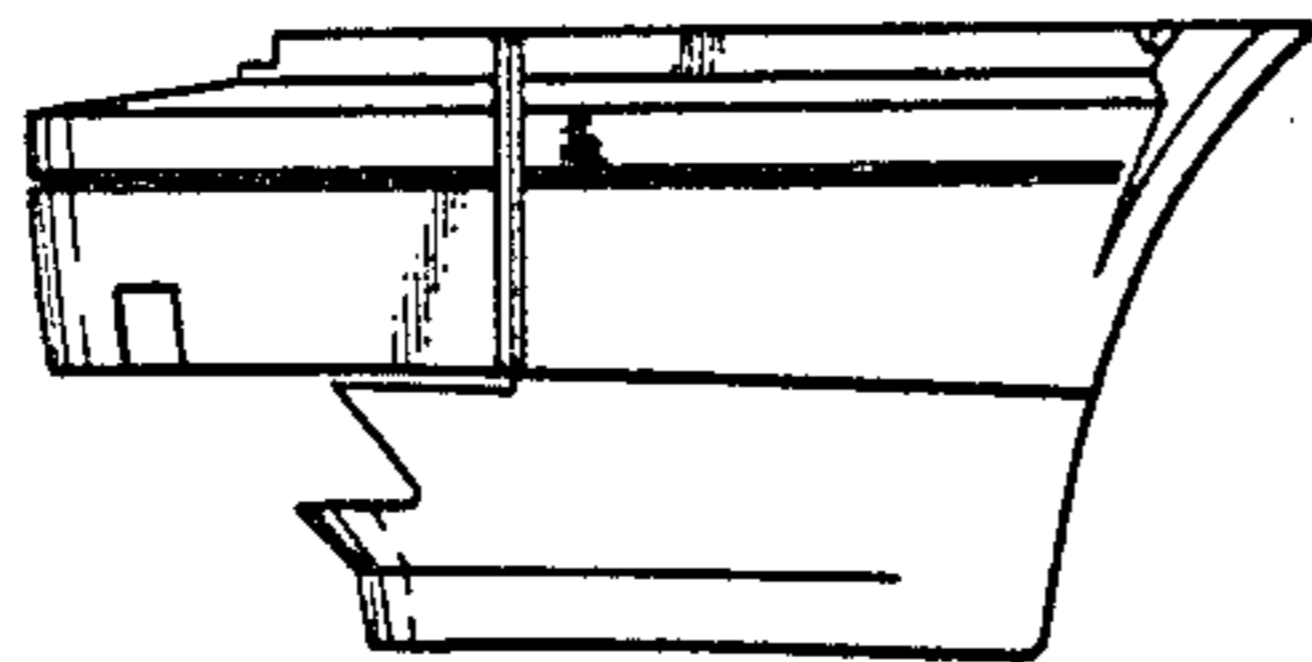

Fig. 7

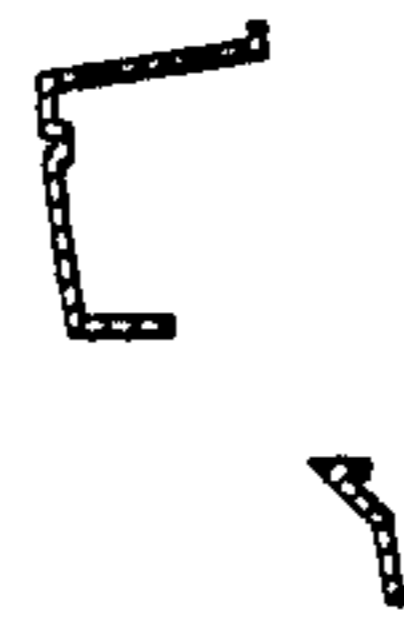

Fig. 8

