

[54] VEHICLE OPERATOR'S FOLD UP FOOT REST

[76] Inventor: Larry D. Morris, 5095 S. 6300 West, Hooper, Utah 84315

[**] Term: 14 Years

[21] Appl. No.: 590,634

[22] Filed: Mar. 19, 1984

[52] U.S. Cl. D12/114

[58] Field of Search D12/114, 190; 280/291; 296/75; 74/564

[56] References Cited

U.S. PATENT DOCUMENTS

3,784,247 1/1974 Mills 296/75

OTHER PUBLICATIONS

J. C. Whitney Motorcycle Parts & Accessories Catalog,

No. 28C, p. 66, Foot Rest for ATVs, B, top right side of page.

Primary Examiner—James M. Gandy
Attorney, Agent, or Firm—A. Ray Osburn

[57] CLAIM

The ornamental design for a vehicle operator's fold up foot rest, as shown and described.

DESCRIPTION

FIG. 1 is an upper left perspective view of a vehicle operator's fold up foot rest showing my new design, it being understood that the broken lines are for illustrative purposes only;

FIG. 2 is a similar perspective view thereof in folded up condition;

FIG. 3 is a front elevation view;

FIG. 4 is a top plan view;

FIG. 5 is a left side elevation view;

FIG. 6 is a right side elevation view;

FIG. 7 is a bottom plan view; and

FIG. 8 is a rear elevation view.

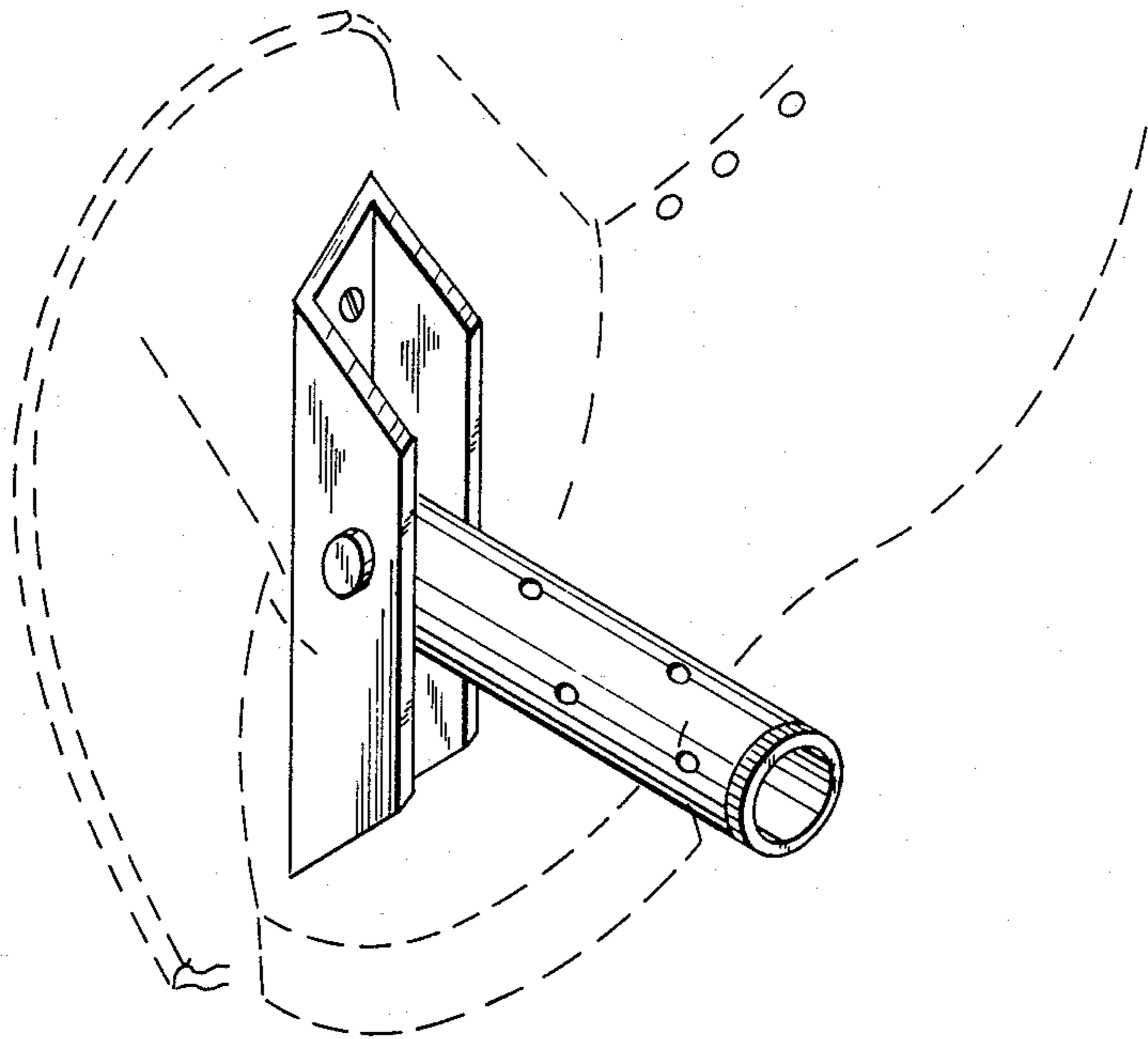

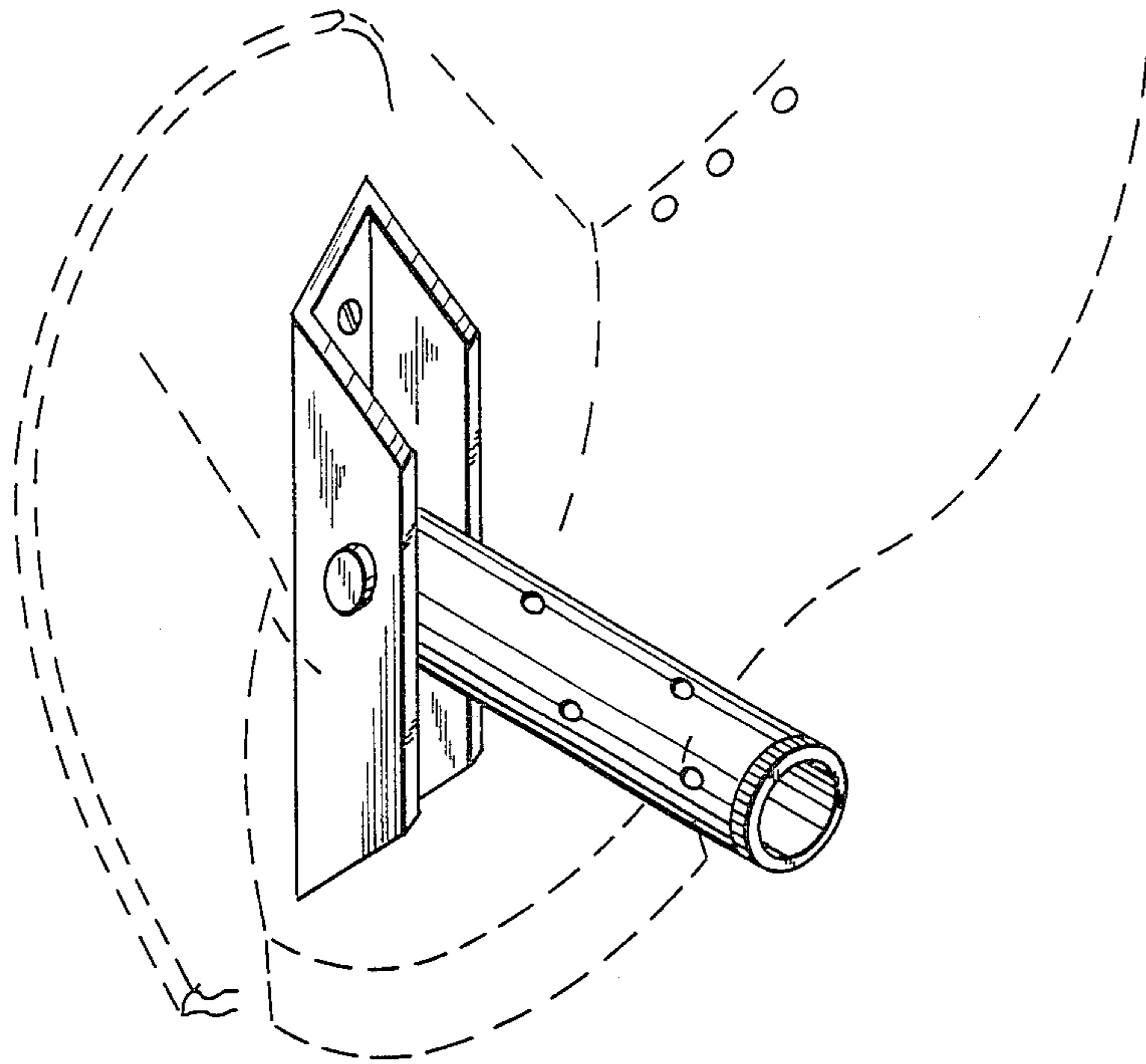

FIG. 1

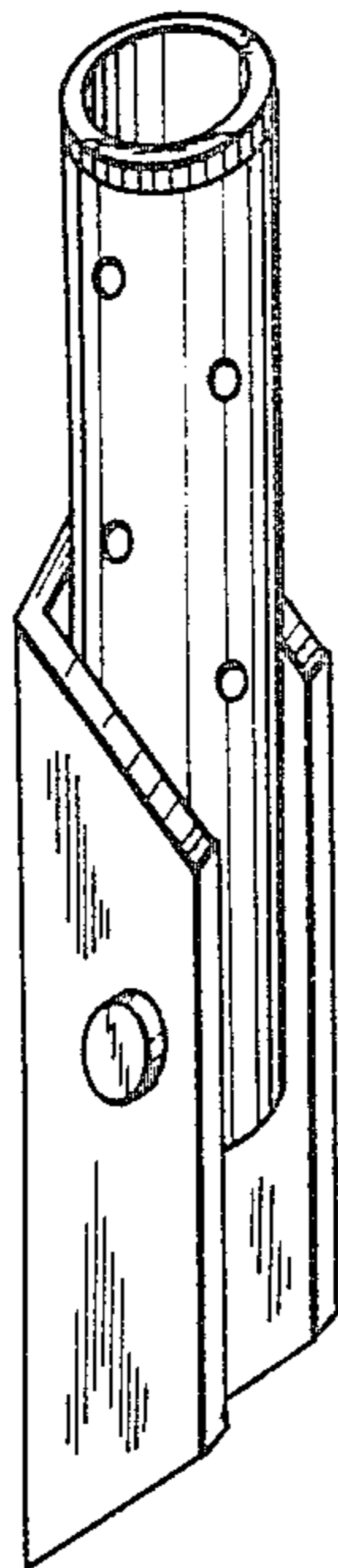

FIG. 2

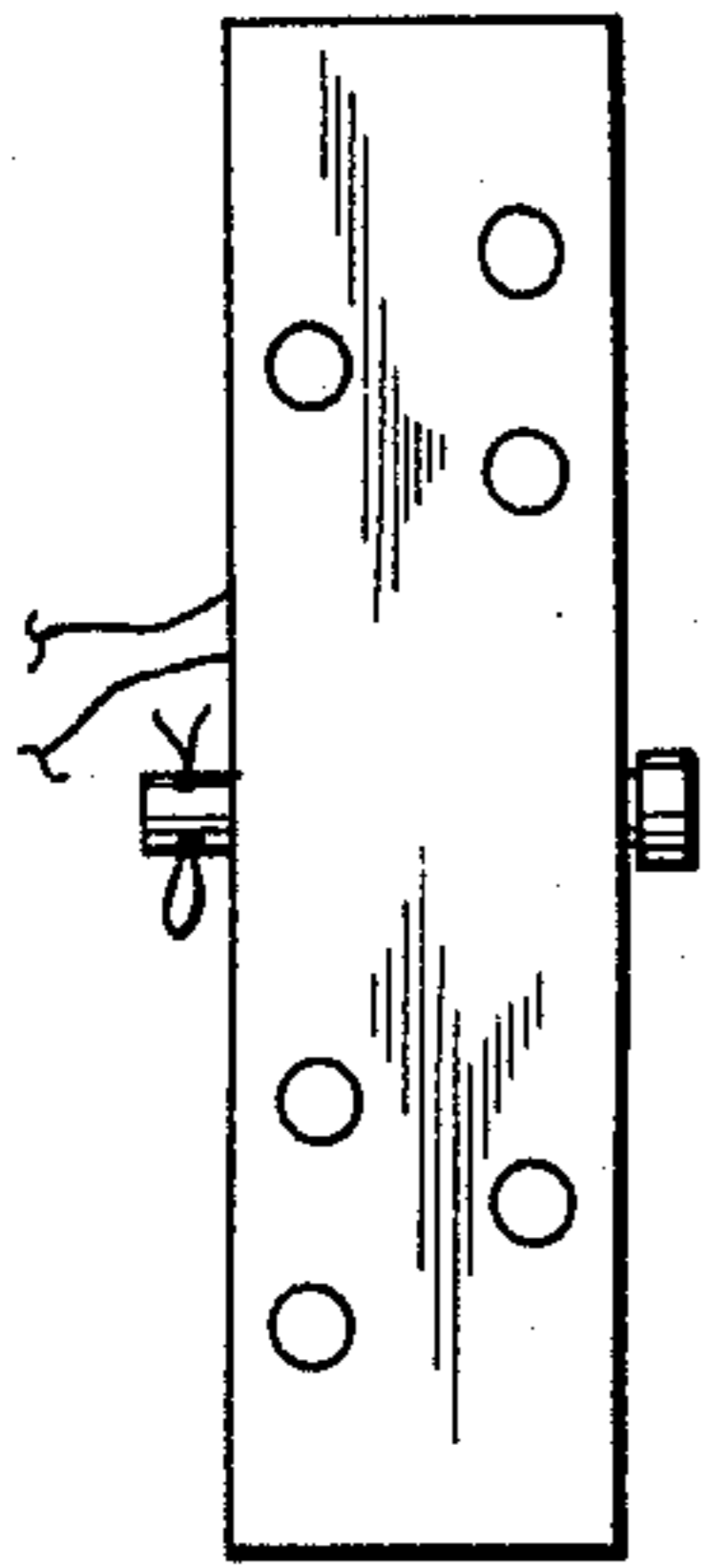

FIG. 8

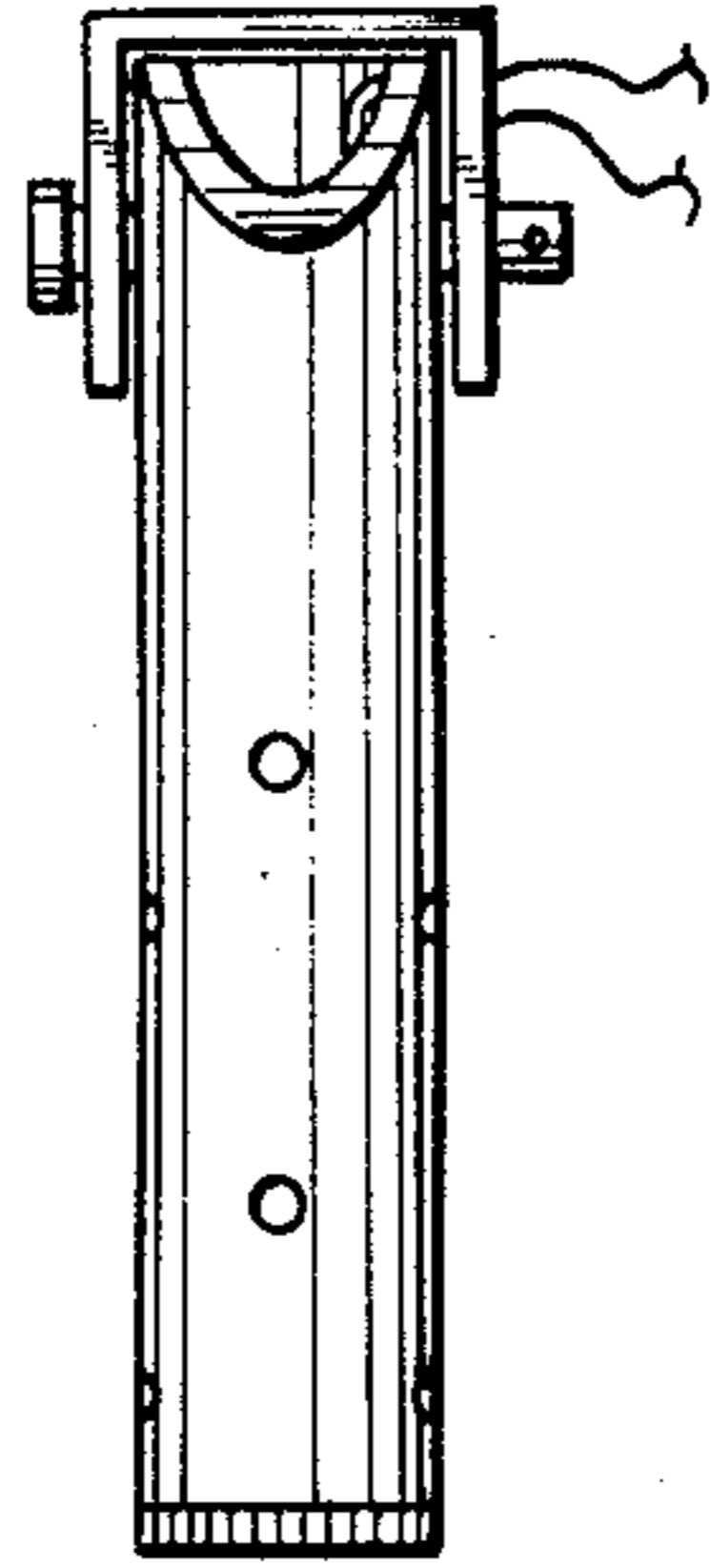

FIG. 4

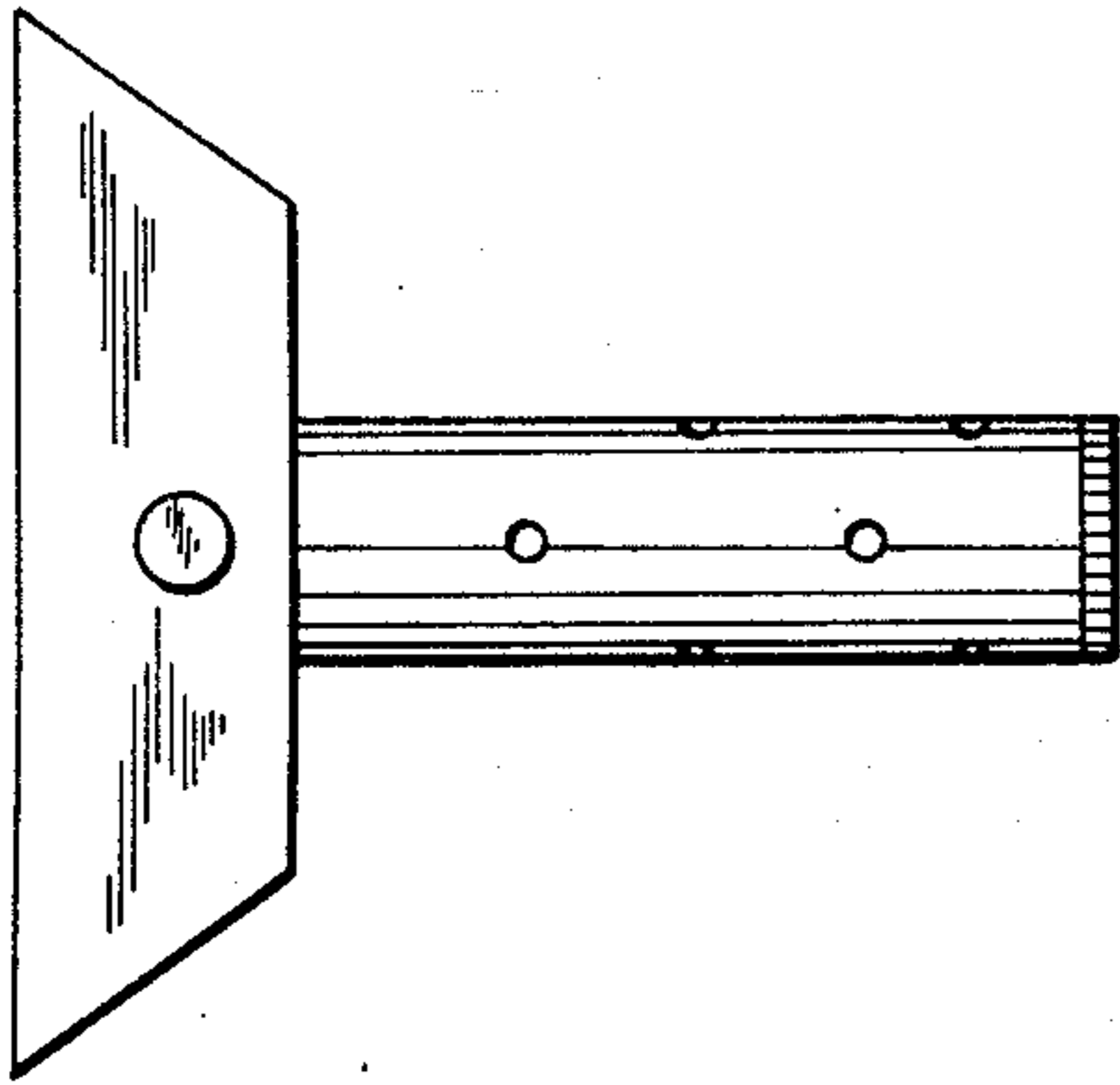

FIG. 5

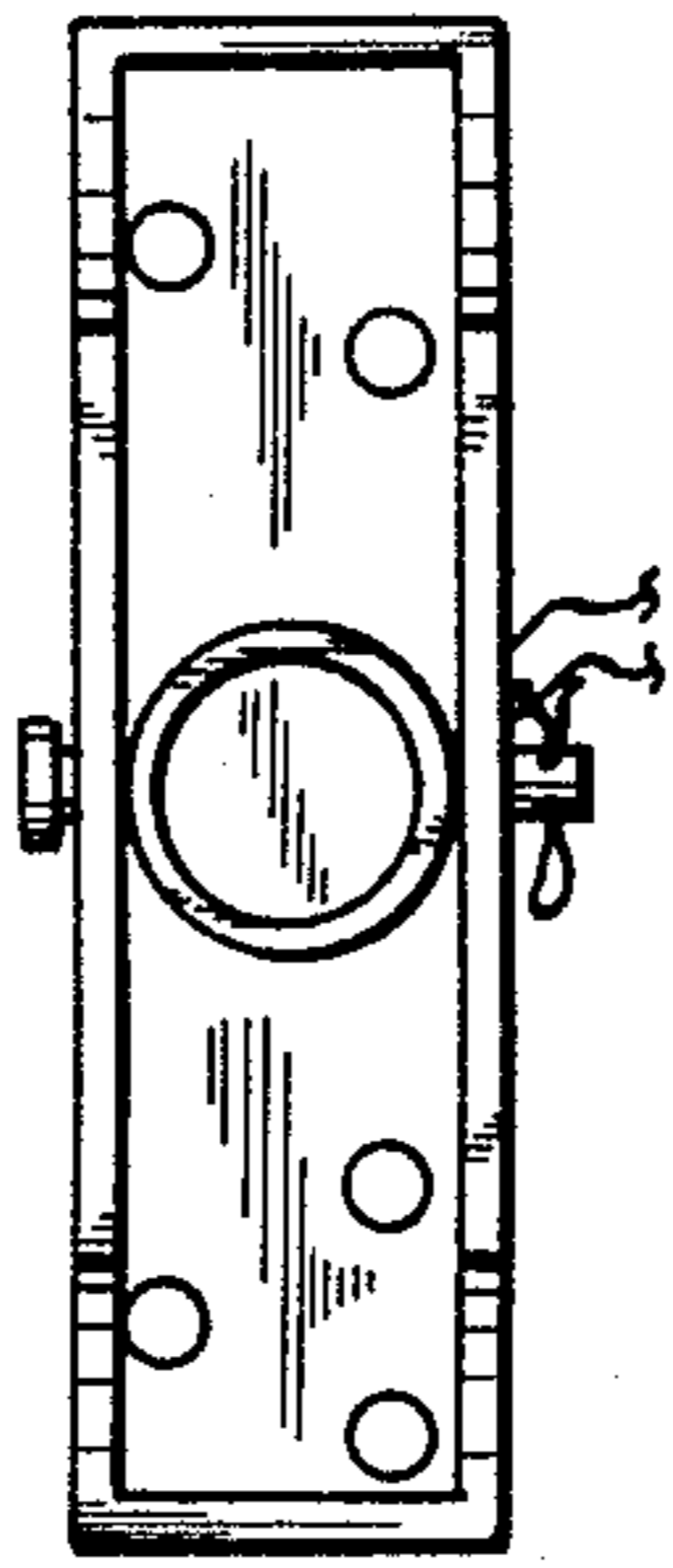

FIG. 3

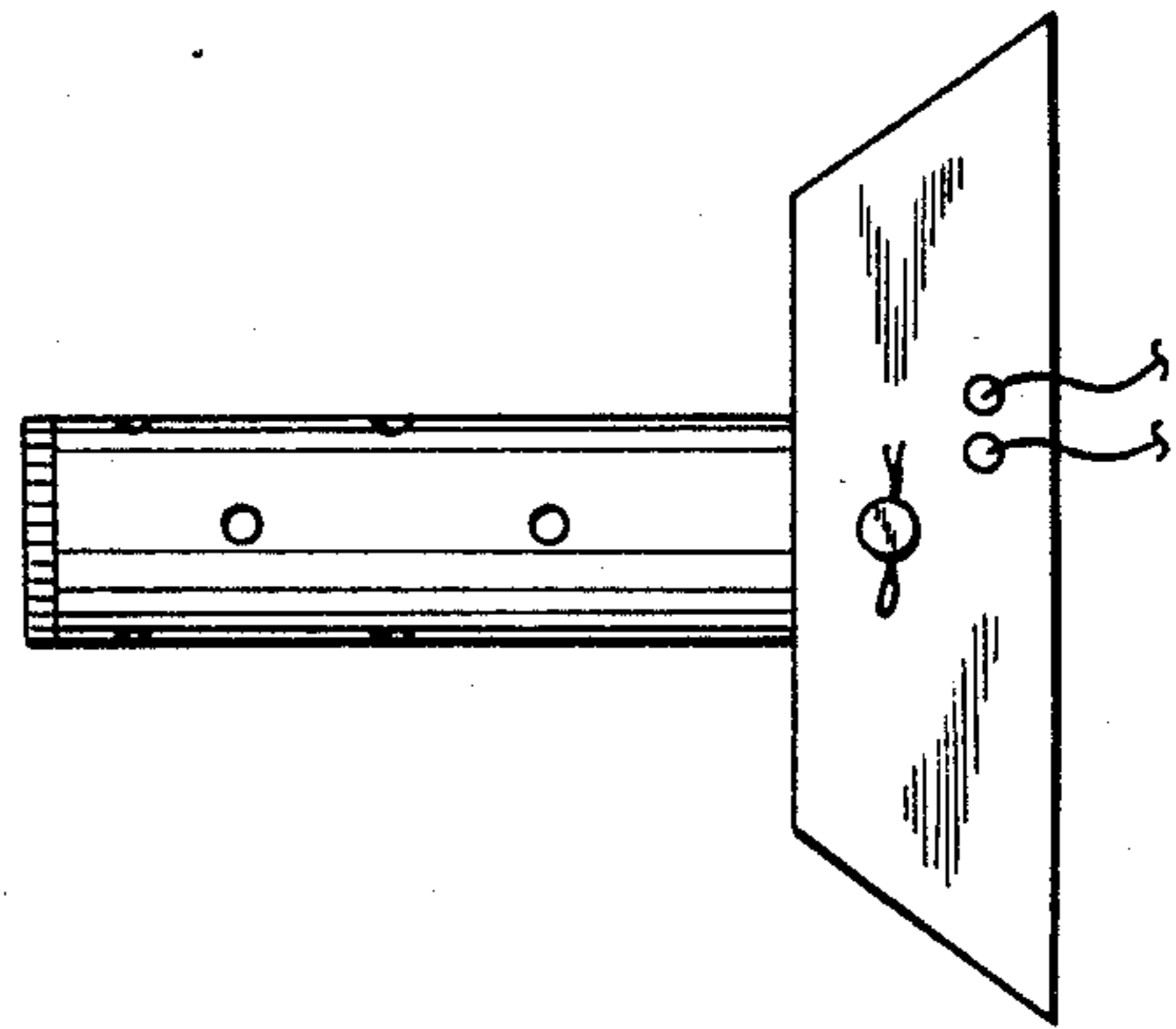

FIG. 6

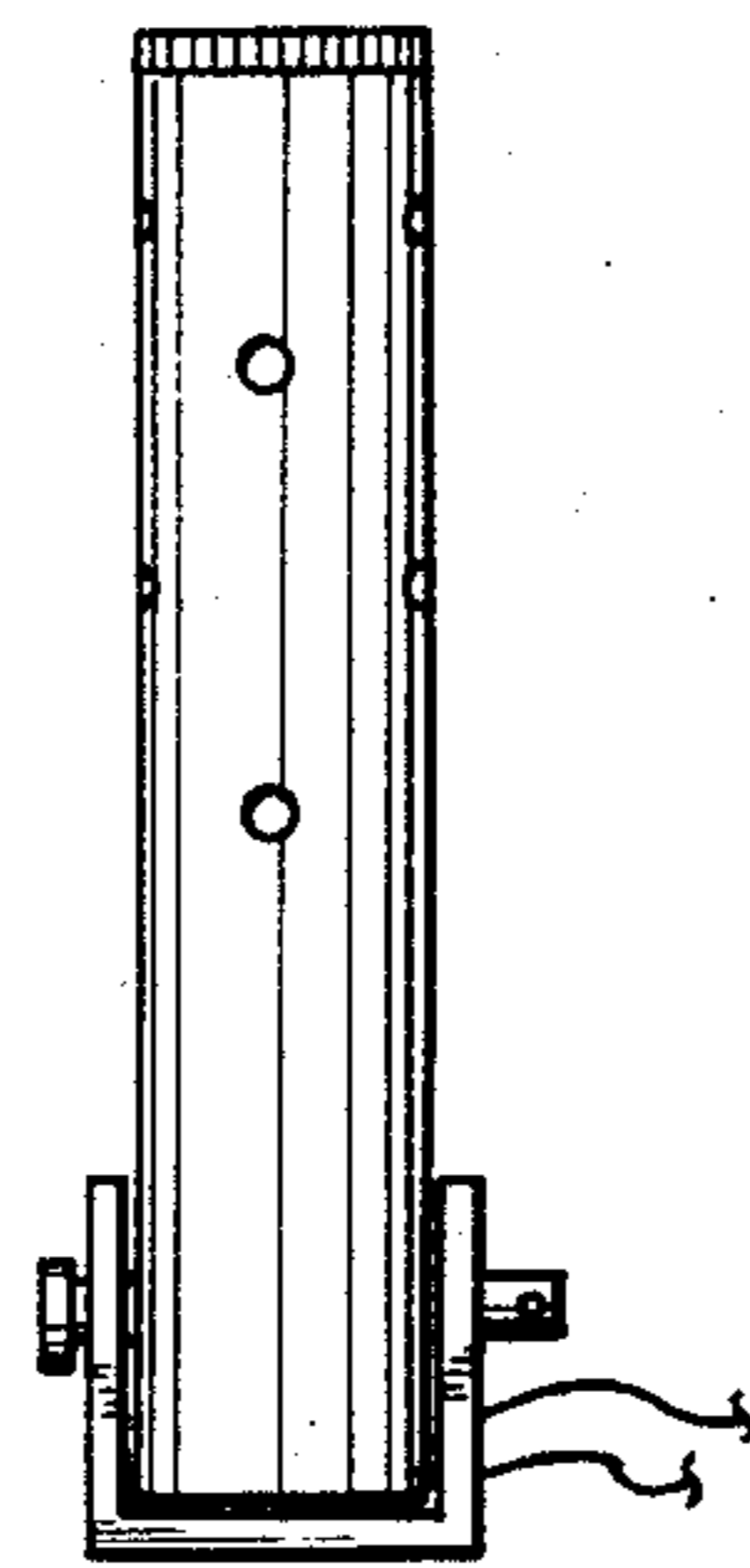

FIG. 7