

[54] COMBINED AUTOMOBILE TAILLIGHT LENS AND COVER

[75] Inventor: Hiroshi Hirano, Yokohama, Japan

[73] Assignee: Nissan Motor Co., Ltd., Yokohama, Japan

[**] Term: 14 Years

[21] Appl. No.: 650,113

[22] Filed: Sep. 13, 1984

[52] U.S. Cl. D26/120; D26/139

[58] Field of Search D26/28-36, D26/118-124, 139; 362/61, 80, 81, 82, 83, 326, 329-340, 309

[56] References Cited

U.S. PATENT DOCUMENTS

D. 247,991 5/1978 Tixier D26/122

D. 271,143 10/1983 Hirakawa D26/120
D. 279,929 7/1985 Teague et al. D26/122

Primary Examiner—Susan J. Lucas
Attorney, Agent, or Firm—Schwartz, Jeffery, Schwaab, Mack, Blumenthal & Evans

[57] CLAIM

The ornamental design for a combined automobile taillight lens and cover, as shown and described.

DESCRIPTION

FIG. 1 is a perspective view of a combined automobile taillight lens and cover showing the new design; FIG. 2 is a front elevation view thereof; FIG. 3 is a top plan view thereof; FIG. 4 is a bottom plan view thereof; FIG. 5 is a right side elevation view thereof; and FIG. 6 is a left side elevation view thereof. The taillight housing is shown in broken lines in FIGS. 1, 3, 4, 5 and 6 for illustrative purposes only.

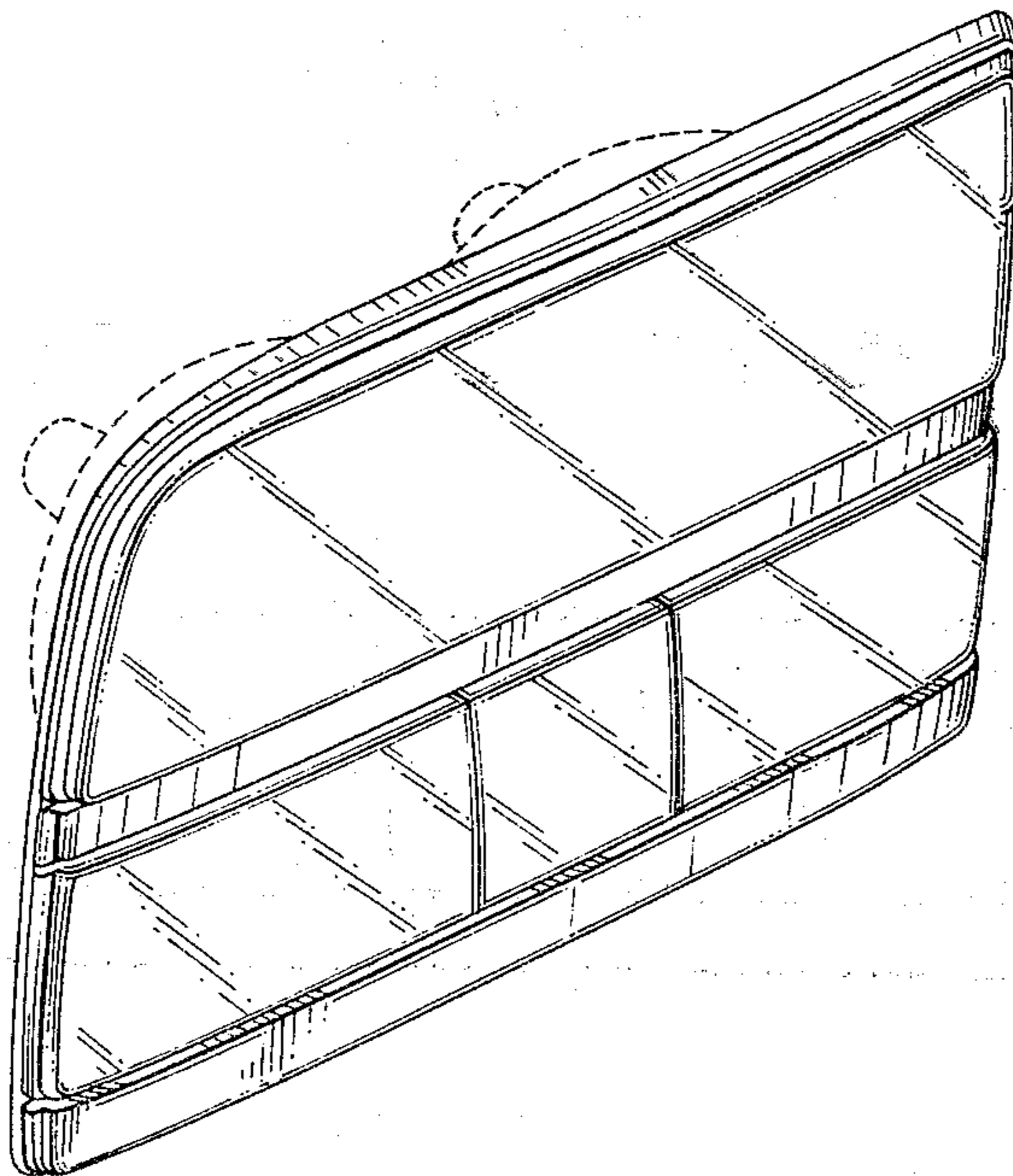

FIG. 1

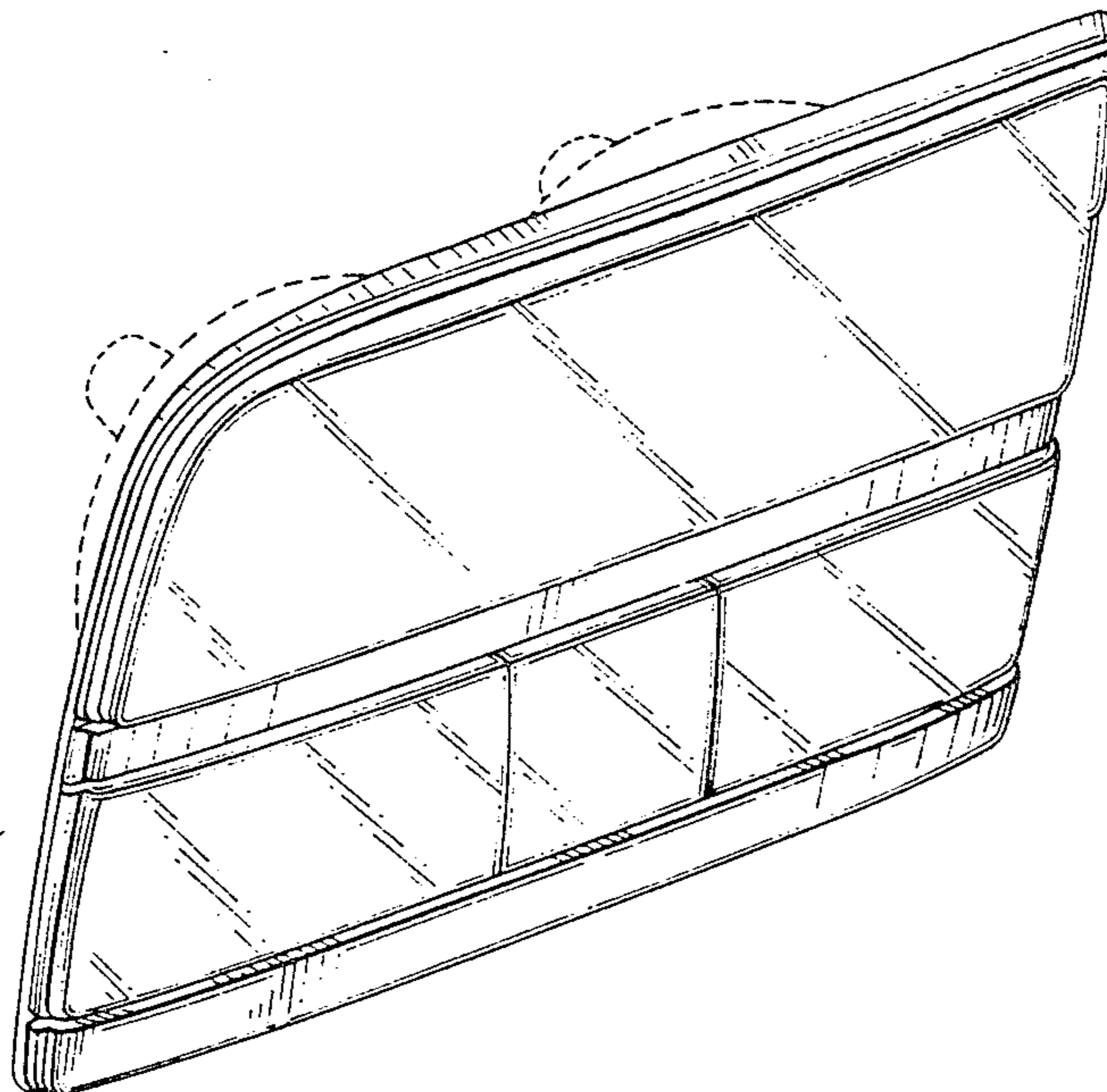

FIG. 2

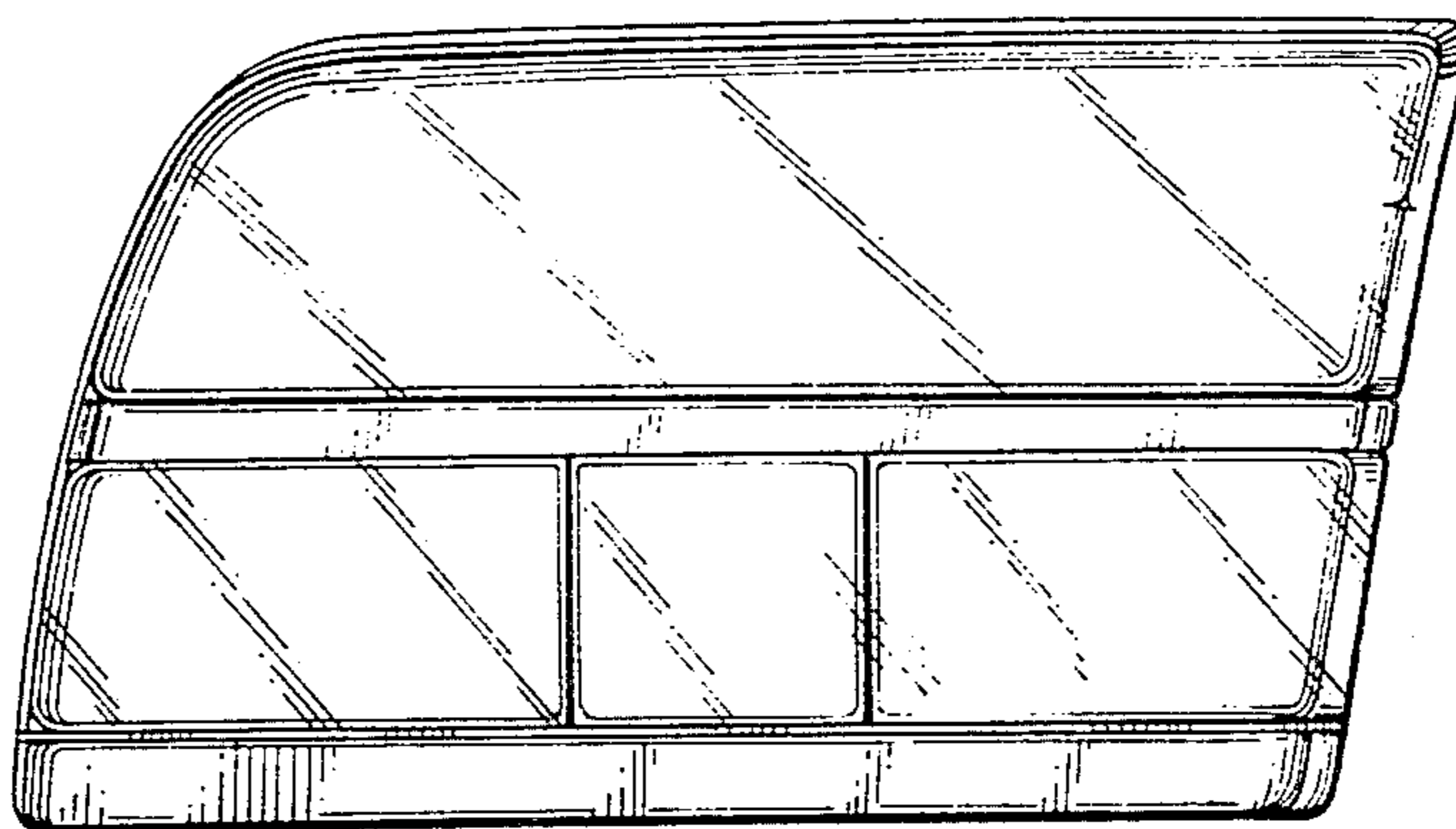

FIG. 3

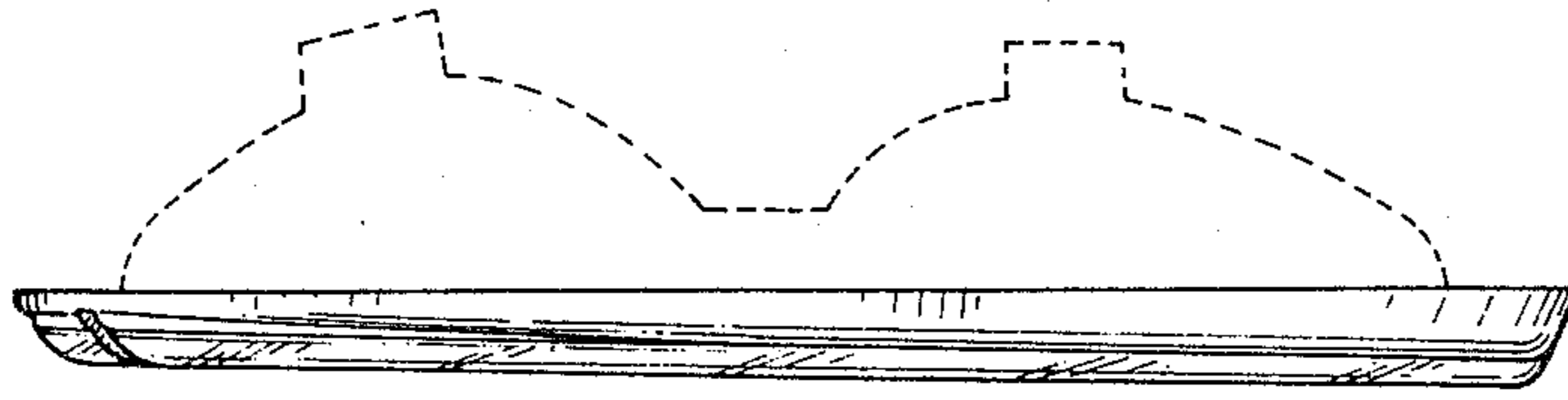

FIG. 4

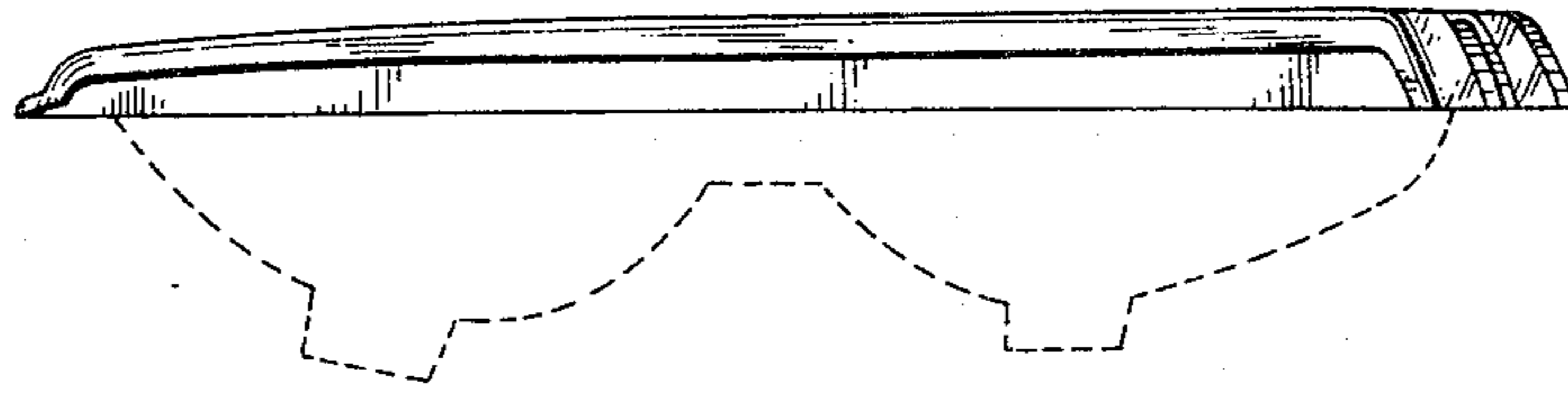

FIG. 6

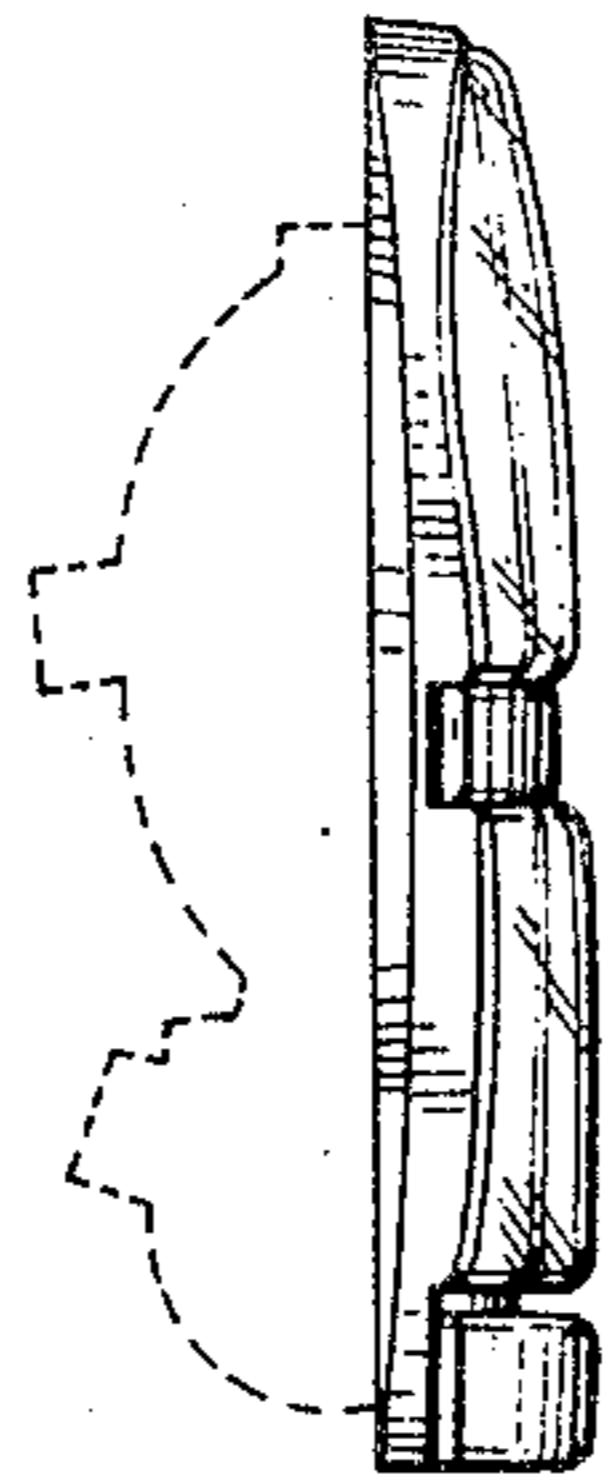

FIG. 5

