

United States Patent [19]

Brechtbill et al.

[11] Patent Number: **Des. 287,962**

[45] Date of Patent: **** Jan. 27, 1987**

[54] **BRACE FOR STABILIZER OF V-TAIL AIRCRAFT**

4,456,204 6/1984 Hapke 244/53 R
4,598,885 7/1986 Waitzman 244/130

[75] Inventors: **George V. Brechtbill**, Wilton, Calif.;
Charlie O. Nicolos, 3501 East View
Dr., Shingle Springs, Calif. 95682

Primary Examiner—James M. Gandy
Assistant Examiner—Kay H. Chin
Attorney, Agent, or Firm—Lothrop & West

[73] Assignee: **Charlie O. Nicolos**, Shingle Springs,
Calif.

[57] **CLAIM**

The ornamental design for a brace for stabilizer of V-tail aircraft, as shown and described.

[**] Term: **14 Years**

[21] Appl. No.: **611,238**

[22] Filed: **May 17, 1984**

[52] U.S. Cl. **D12/345**

[58] Field of Search D12/345; 244/130, 87,
244/53 R

DESCRIPTION

FIG. 1 is a front perspective view of a brace for stabilizer of V-tail aircraft, showing our new design;
FIG. 2 is a top plan view thereof;
FIG. 3 is a front elevational view thereof;
FIG. 4 is a bottom plan view thereof;
FIG. 5 is a rear elevational view thereof;
FIG. 6 is a side elevational view thereof; and
FIG. 7 is a side elevational view of the side opposite that shown in FIG. 6 thereof.

[56] **References Cited**

U.S. PATENT DOCUMENTS

2,927,749 3/1960 Brownell 244/130

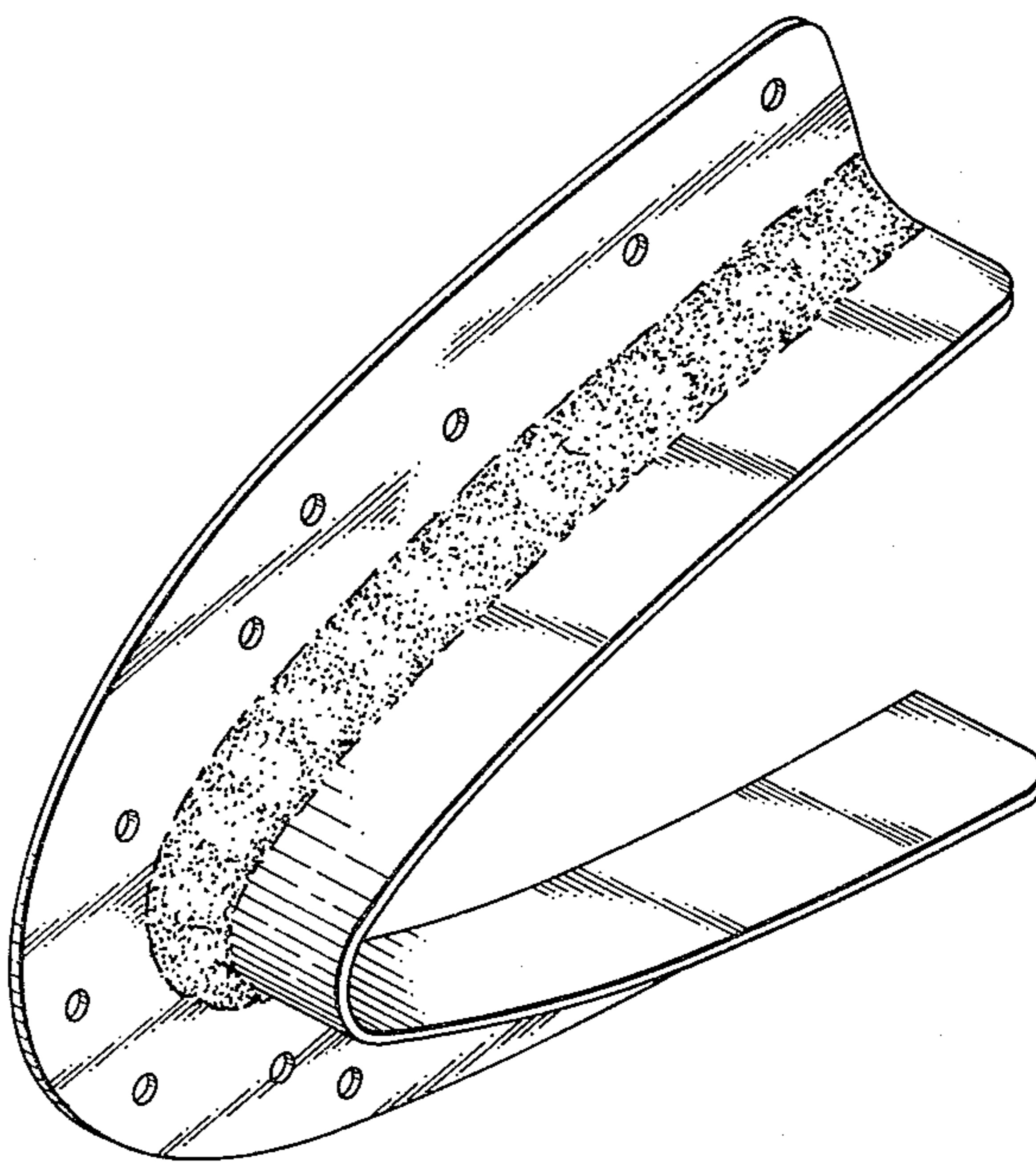

FIG. 1.

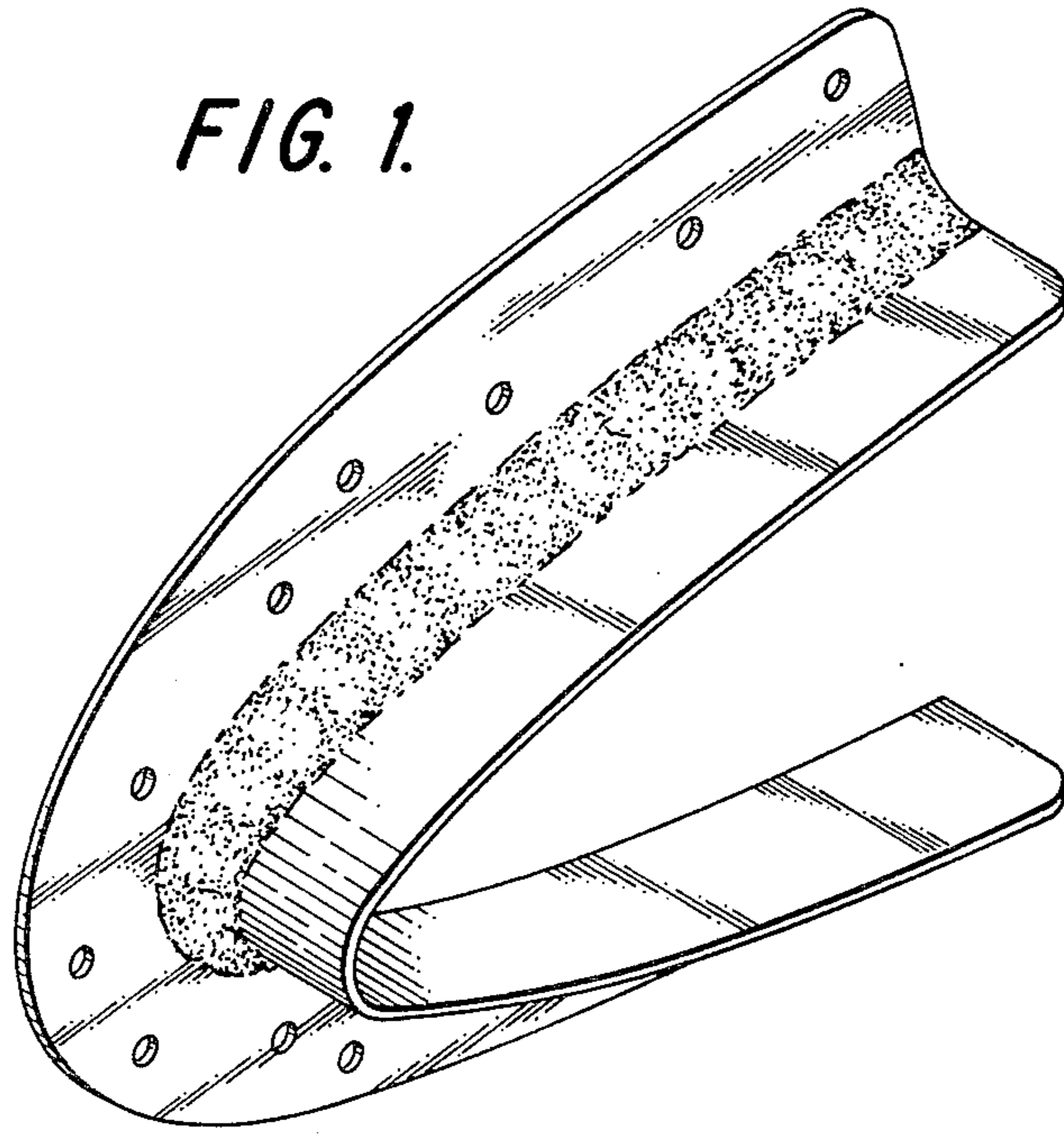

FIG. 2.

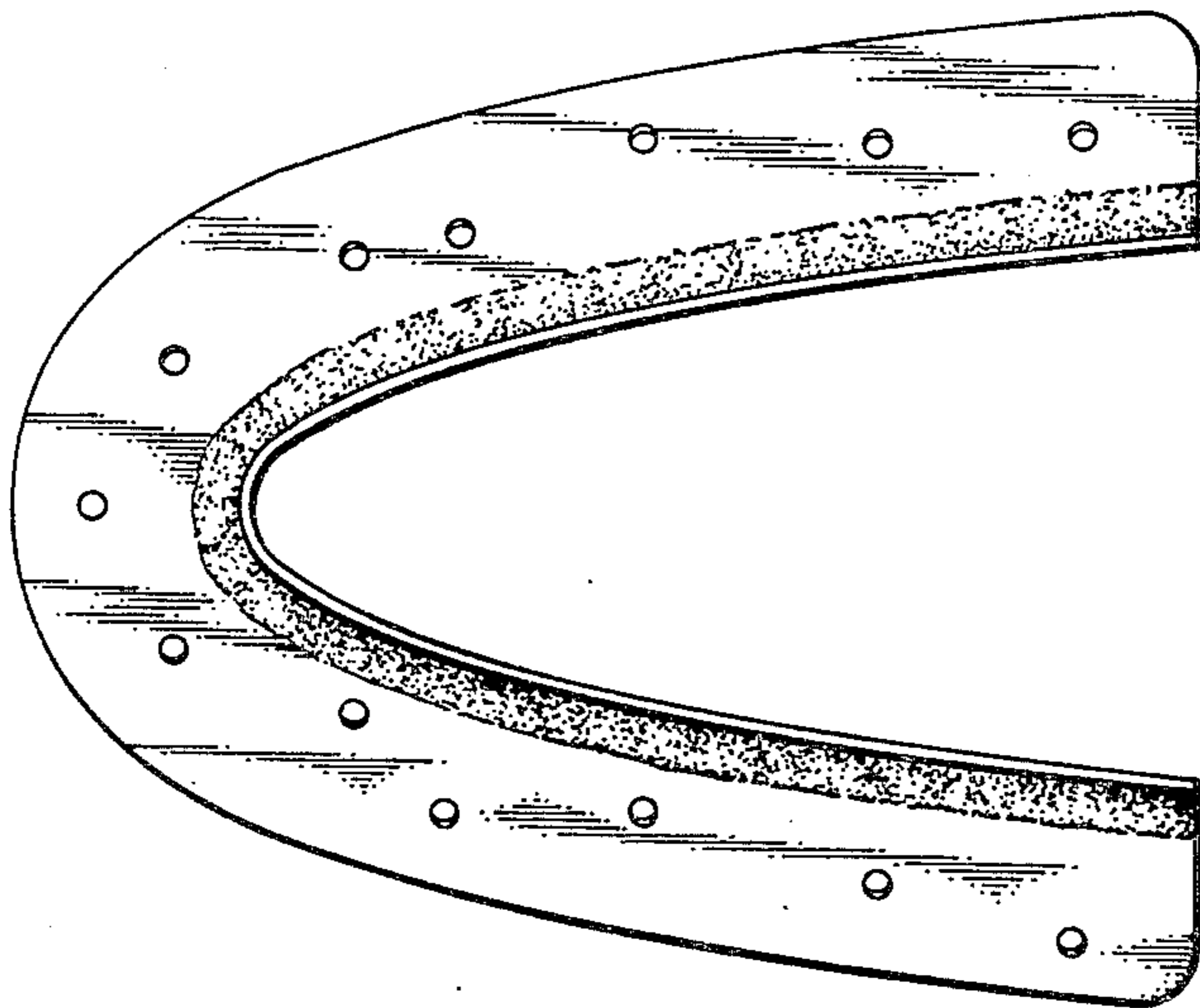

FIG. 3.

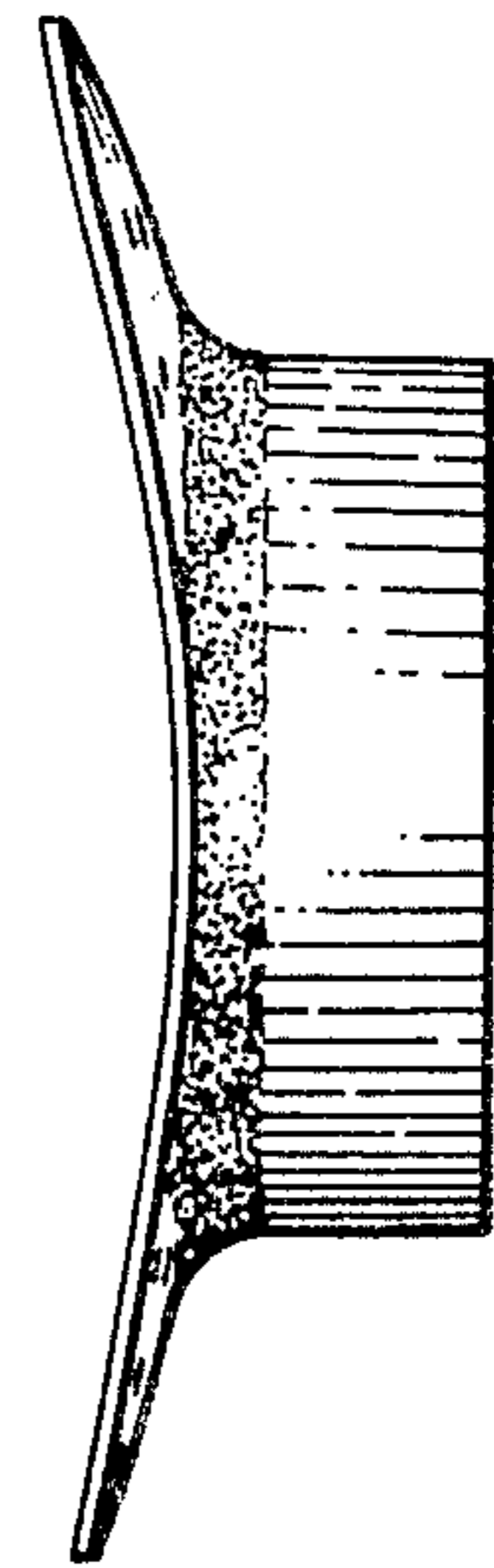

FIG. 4.

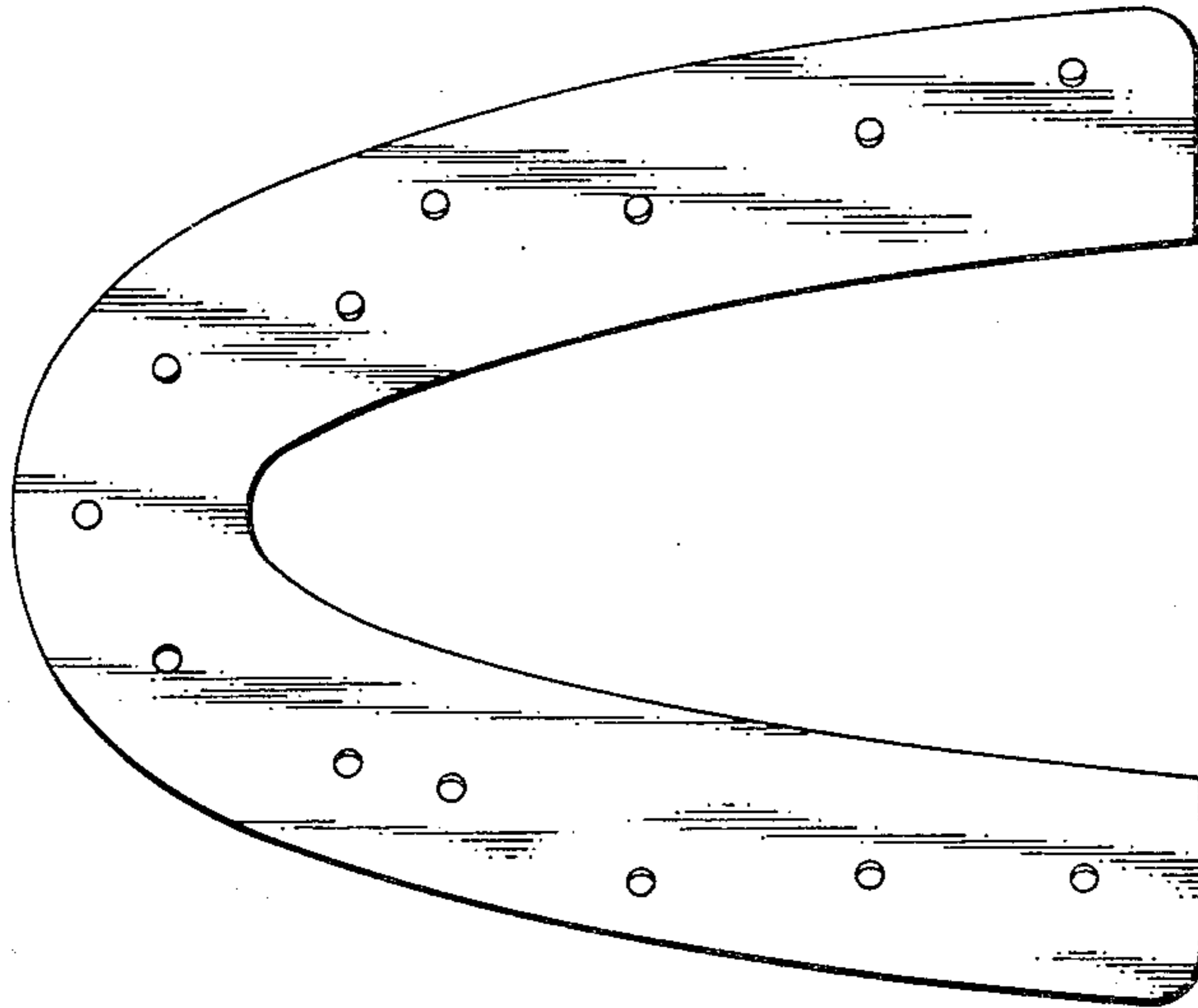

FIG. 5.

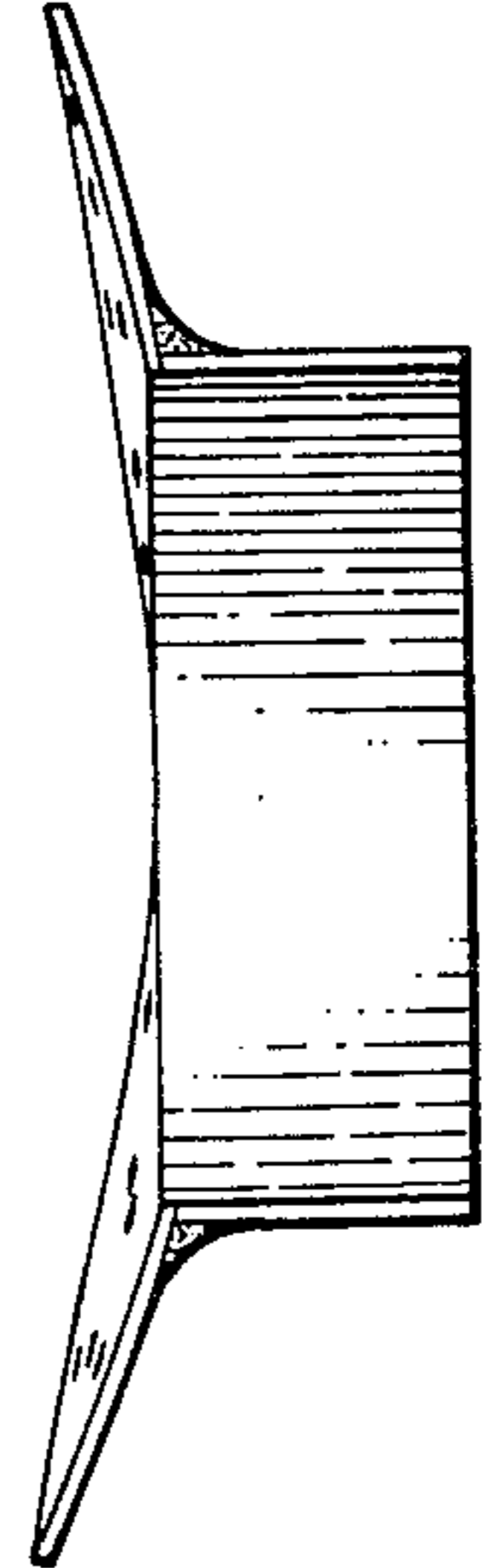

FIG. 6.

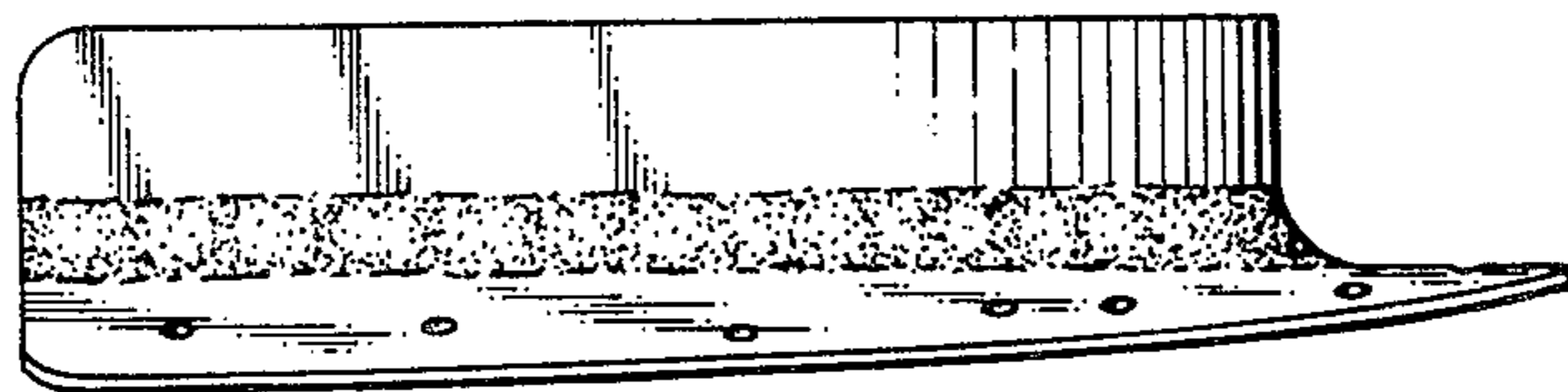
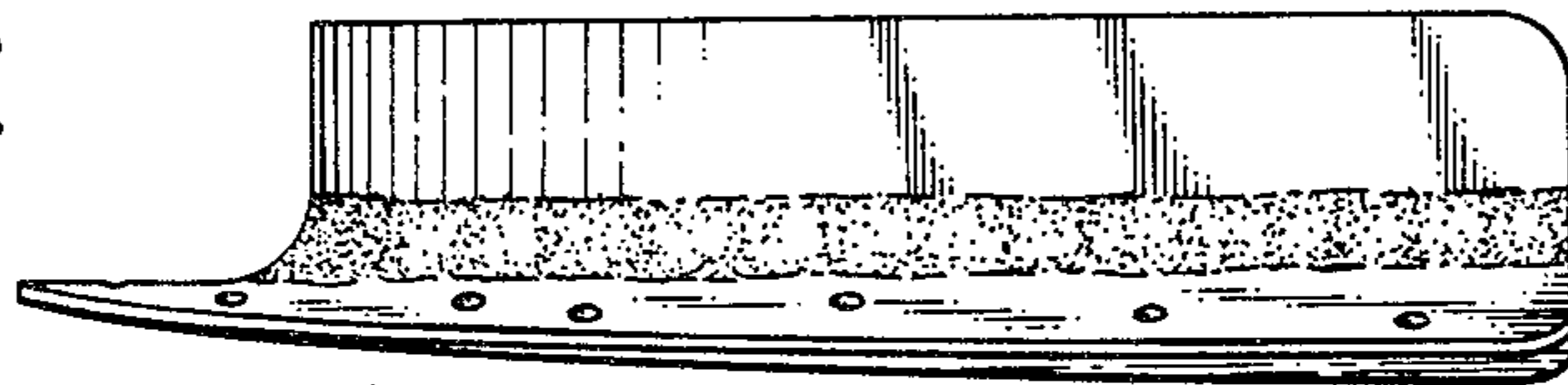

FIG. 7.