

[54] FRONT FENDER FOR AN AUTOMOBILE

[75] Inventors: Kintaro Matsumoto, Hino; Mitsuo Kato; Hideto Kikuchi, both of Hachioji, all of Japan

[73] Assignee: Toyota Jidosha Kabushiki Kaisha, Toyota, Japan

[**] Term: 14 Years

[21] Appl. No.: 638,655

[22] Filed: Aug. 7, 1984

[52] U.S. Cl. D12/184

[58] Field of Search D12/184; 280/152 R, 280/153 R

[56] References Cited

U.S. PATENT DOCUMENTS

- D. 189,531 1/1961 Siebert D12/184
- D. 240,914 8/1976 Wilsgaard D12/184
- D. 246,708 12/1977 Tixier D12/184

OTHER PUBLICATIONS

Hot Rod, 6/83, p. 16, Front Fender of Toyota Pickup Truck, bottom of page.

Hot Rod, 4/83, p. 7, Front Fender of Nissan Pickup Truck, bottom of page.

Road & Track, 5/83, p. 225, Front Fender of Toyota Camry, top of page.

Primary Examiner—James M. Gandy
Attorney, Agent, or Firm—Cushman, Darby & Cushman

[57] CLAIM

The ornamental design for a front fender for an automobile, as shown and described.

DESCRIPTION

FIG. 1 is a perspective view of a front fender for an automobile showing our new design;

FIG. 2 is a front elevational view thereof;

FIG. 3 is a rear elevational view thereof;

FIG. 4 is a top plan view thereof;

FIG. 5 is a bottom plan view thereof;

FIG. 6 is a right side elevational view thereof;

FIG. 7 is a left side elevational view thereof; and

FIG. 8 is a perspective view thereof on a reduced scale, it being understood that the broken lines are for illustrative purpose only.

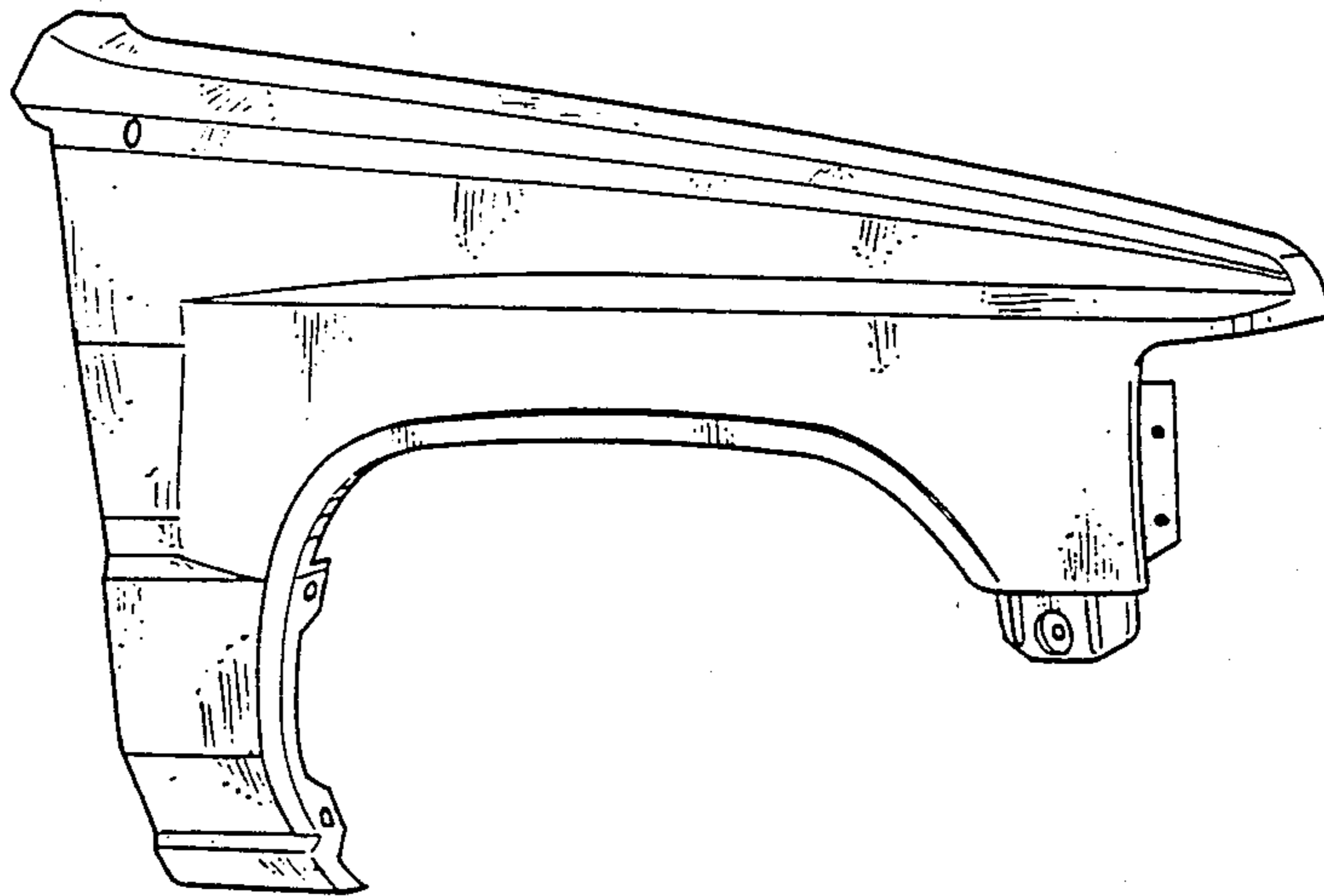

Fig. 1

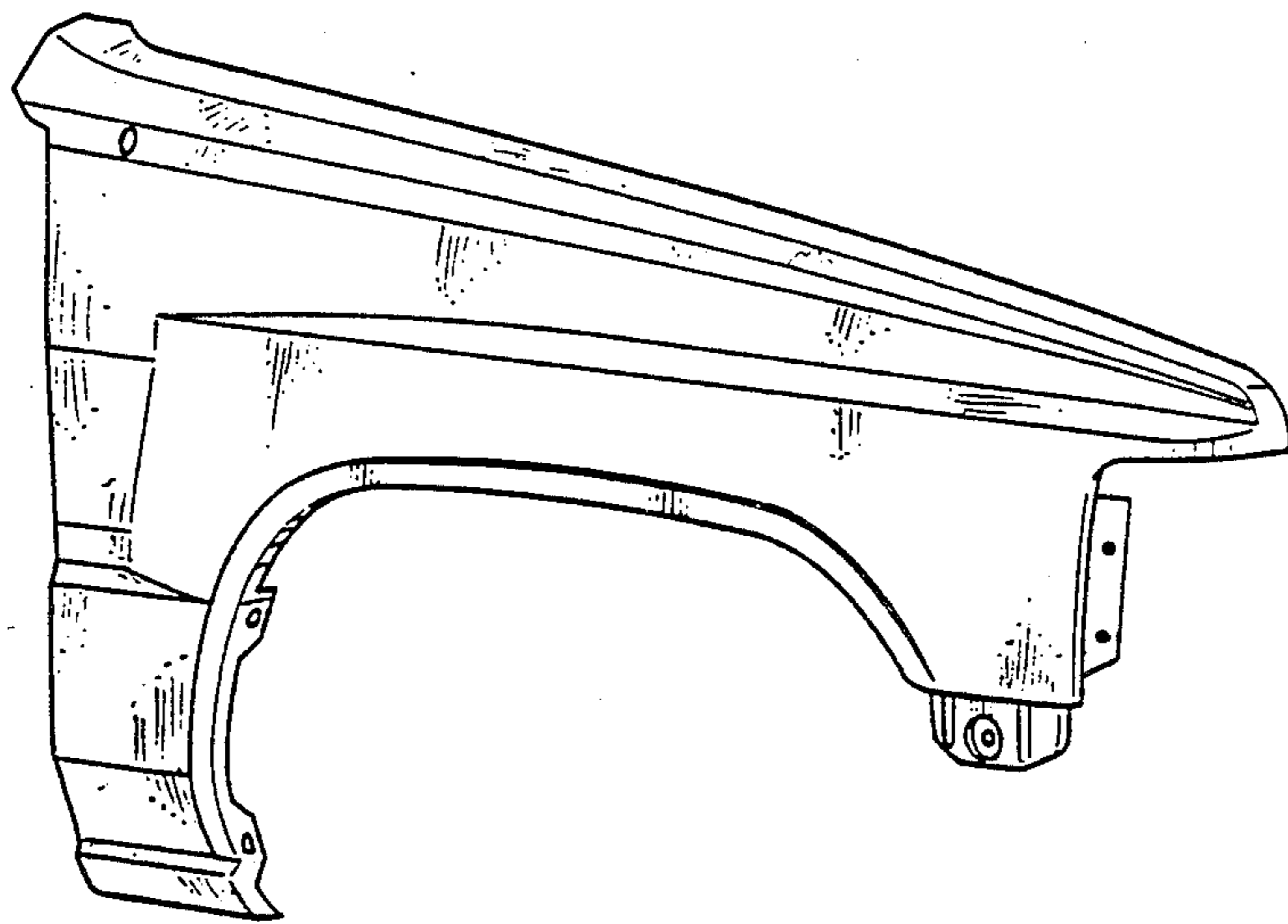

Fig. 2

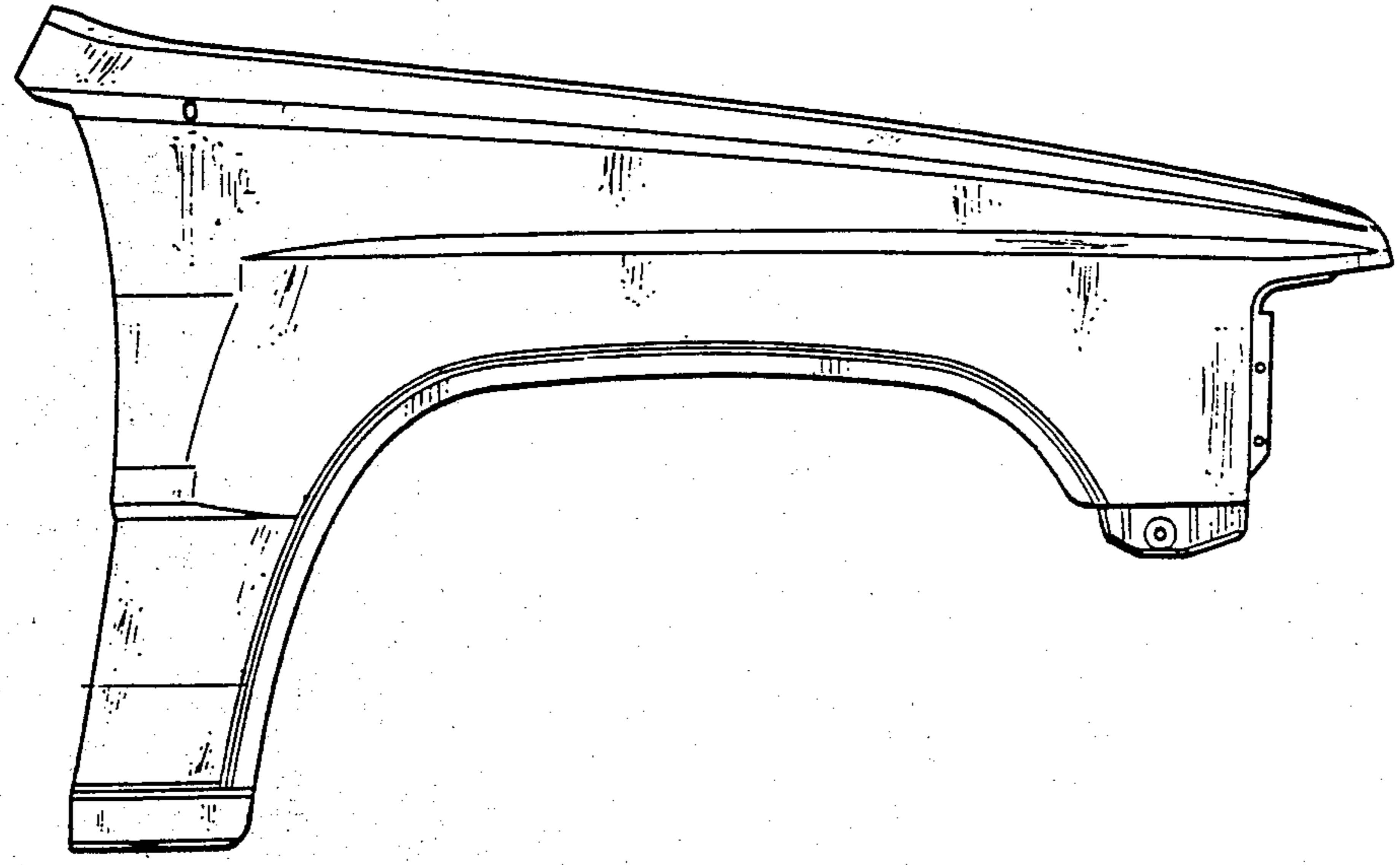

Fig. 3

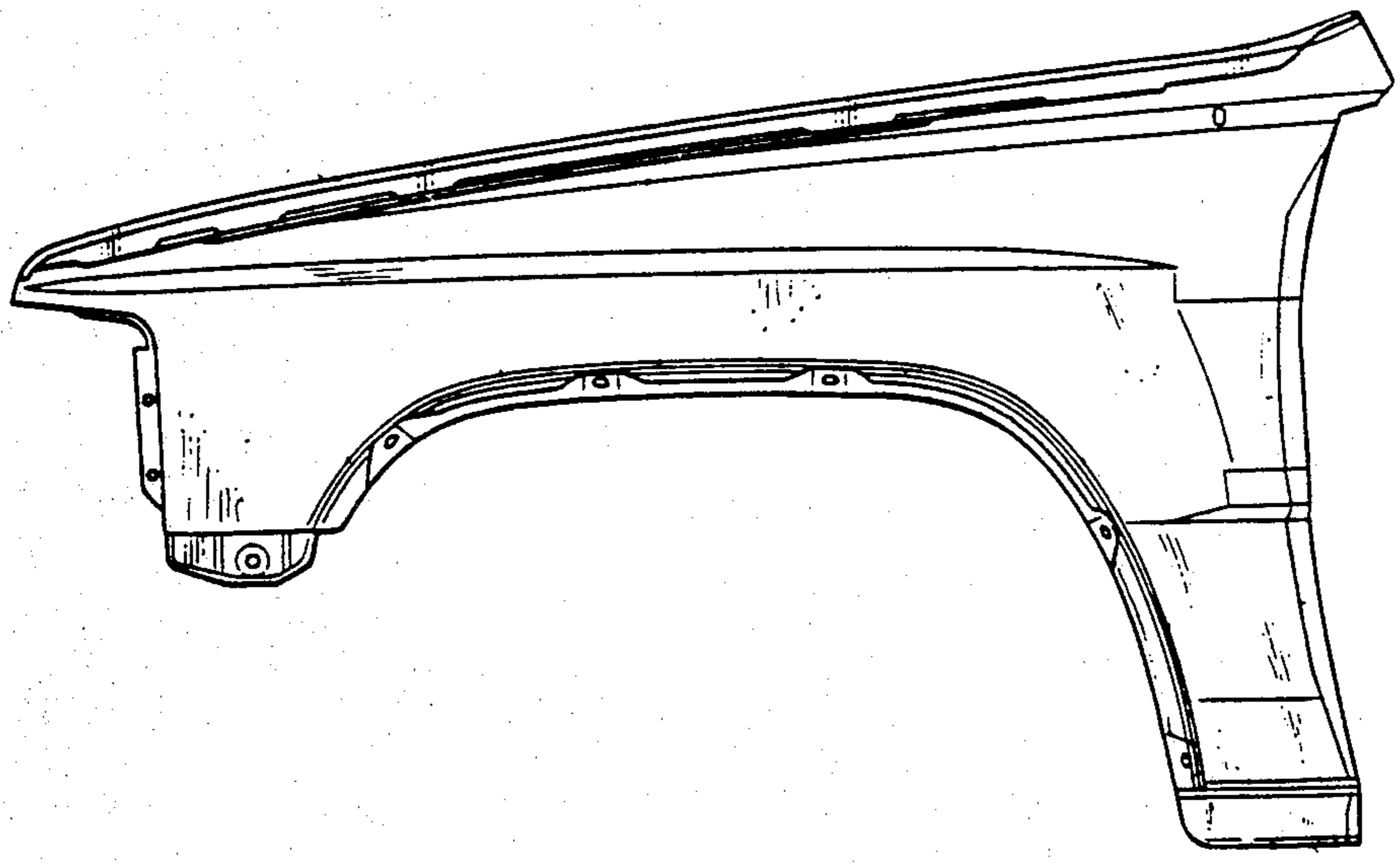

Fig. 4

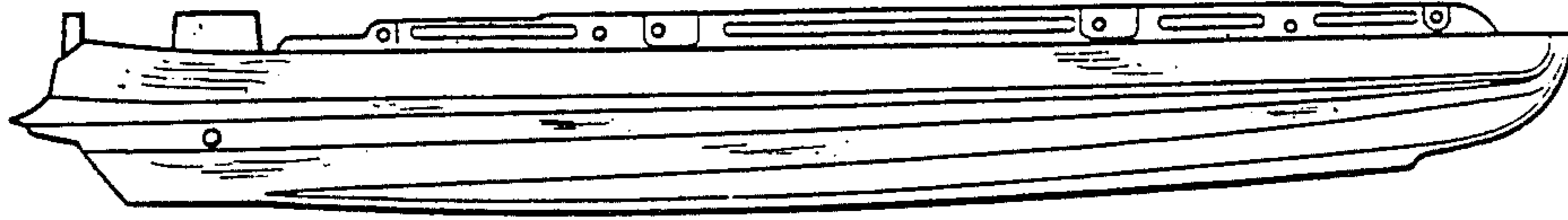

Fig. 5

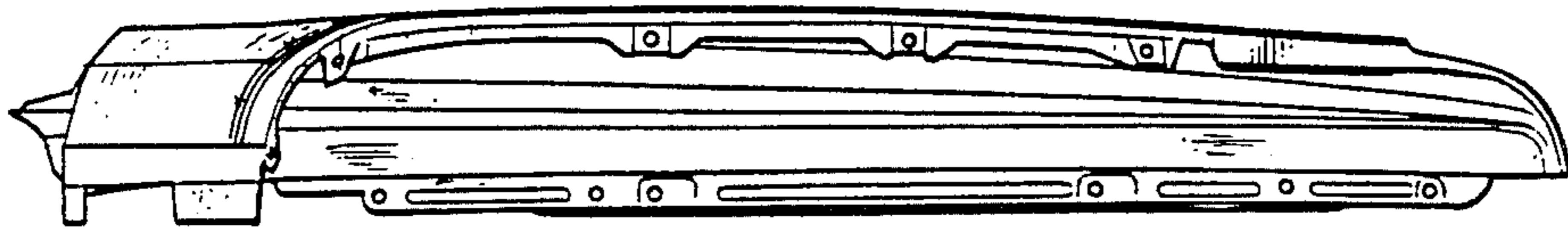

Fig. 6

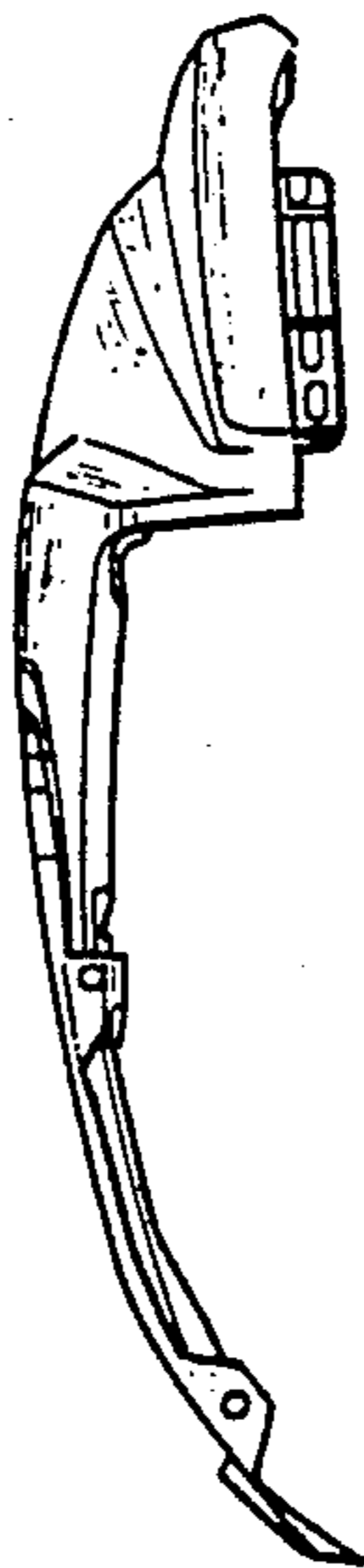

Fig. 7



Fig. 8

