

[54] **AERODYNAMIC SPOILER FOR ATTACHMENT TO AN AUTOMOBILE**

[75] Inventors: **Björn E. A. Envall**, Vänersborg, Sweden; **Giorgetto Giugiaro**, Turin, Italy

[73] Assignee: **Saab-Scania Aktiebolag**, Trollhattan, Sweden

[**] Term: **14 Years**

[21] Appl. No.: **603,945**

[22] Filed: **Apr. 24, 1984**

[30] **Foreign Application Priority Data**

Oct. 26, 1983 [SE]	Sweden	83-2778
[52] U.S. Cl.		D12/181
[58] Field of Search		D12/181; 296/1.5

[56] **References Cited PUBLICATIONS**

Road & Track, 8/83, p. 136, Mercedes-Benz Front Spoiler, bottom right side of page.
 Road & Track, 5/83, p. 187, Mercedes-Benz Front Spoiler, center of page.
 Road & Track, 7/83, p. 109, Buick Sky Hawk Front Spoiler, bottom of page.

Primary Examiner—James M. Gandy
Attorney, Agent, or Firm—Young & Thompson

[57] **CLAIM**

The ornamental design for an aerodynamic spoiler for attachment to an automobile, as shown.

DESCRIPTION

FIG. 1 is a front perspective view of the outside of an aerodynamic spoiler for attachment to an automobile; FIG. 2 is a rear perspective view of the inside thereof; and FIG. 3 is a left side elevation view thereof.

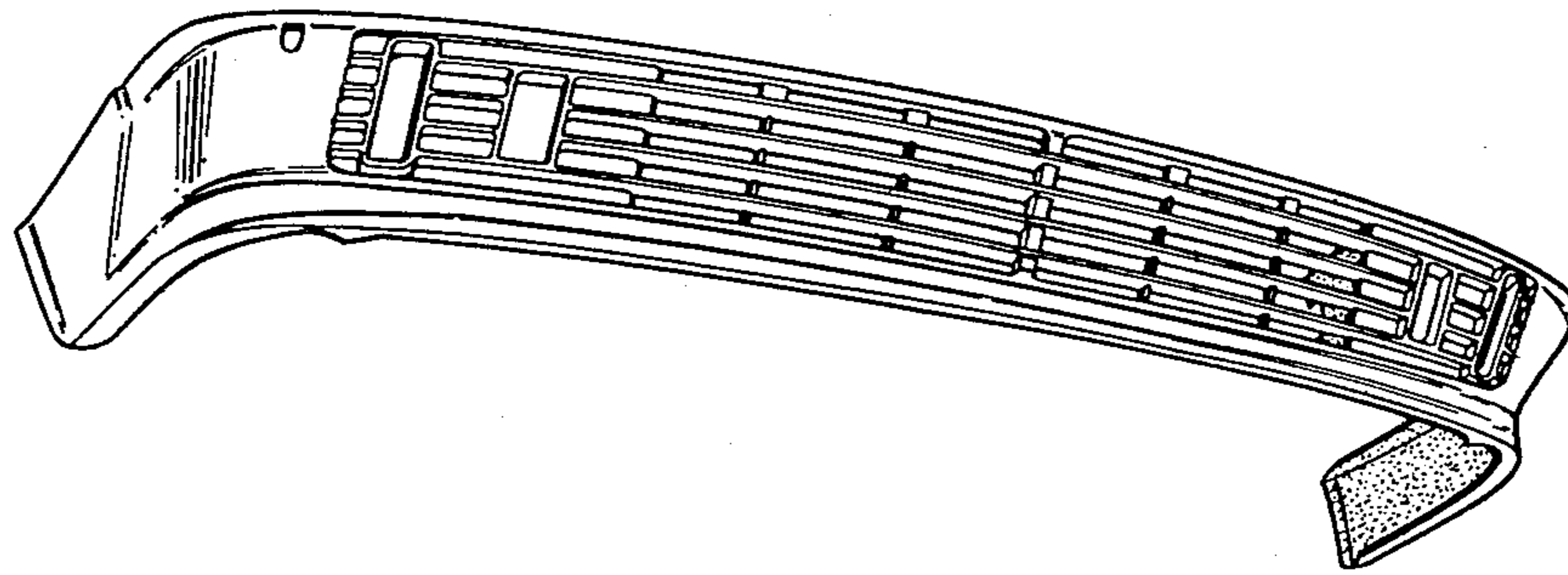

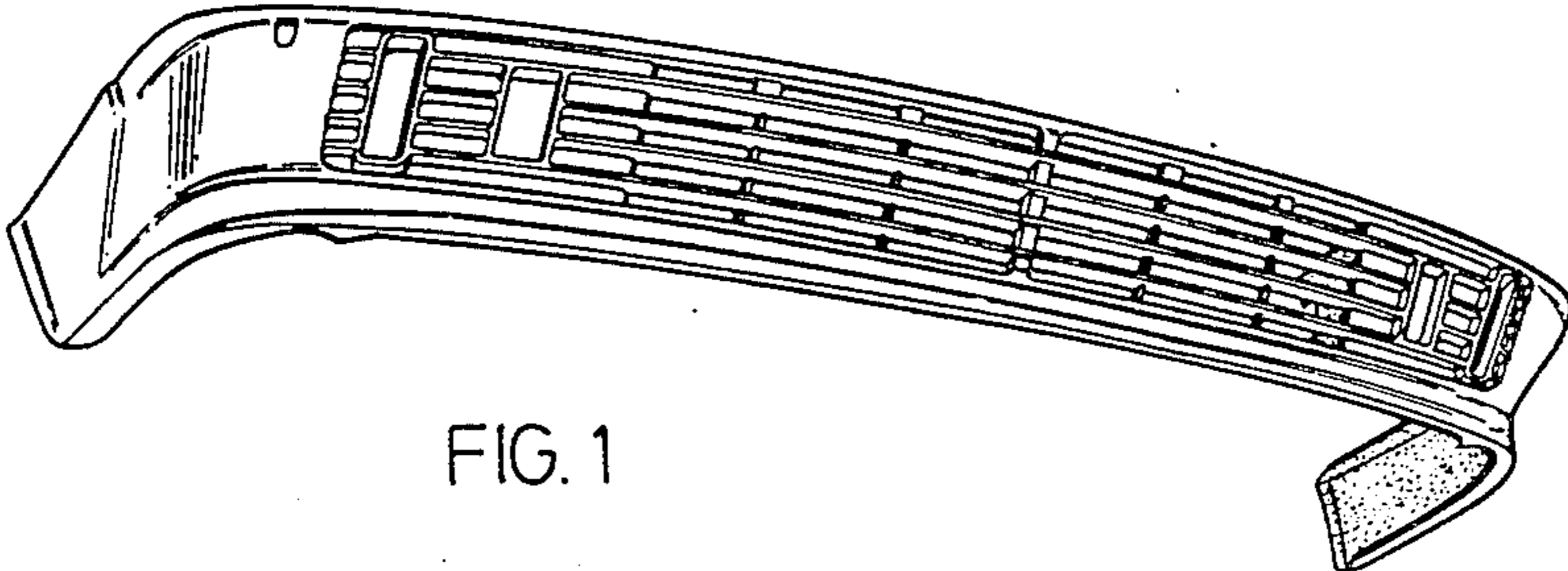

FIG. 1

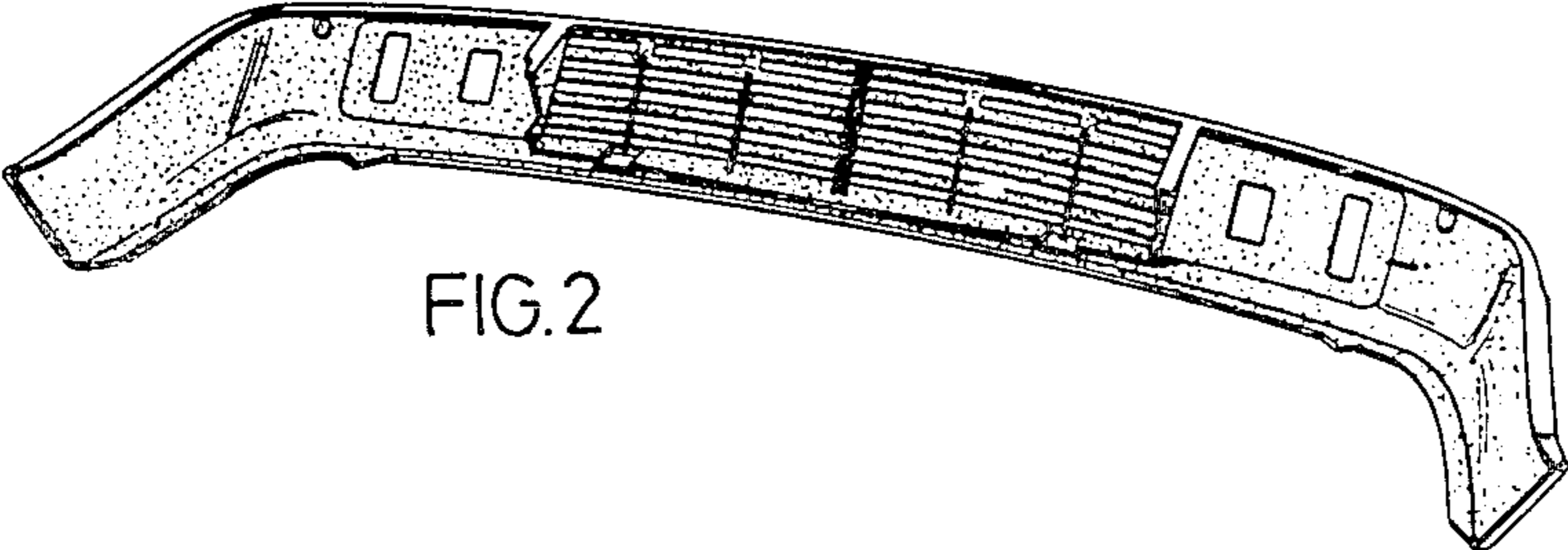

FIG. 2



FIG. 3