

[54] TOTE BAG

[76] Inventors: Janet F. Cathcart, 2210 Wilshire Blvd., #314, Santa Monica, Calif. 90403; Kathleen Ingersoll, 2002 E. 20th St., Santa Ana, Calif. 92701

[**] Term: 14 Years

[21] Appl. No.: 626,975

[22] Filed: Jul. 2, 1984

[52] U.S. Cl. D3/42; D3/52; D3/79

[58] Field of Search D3/30.1, 33, 42, 43, D3/51-53, 71, 76, 77, 78-79; 383/4, 61, 78, 84; 190/1; D7/77

[56] References Cited

U.S. PATENT DOCUMENTS

D. 243,289	2/1977	Solomon	D3/52
D. 281,120	10/1985	Razinowitz	D3/33
2,865,433	12/1958	Warner	383/4

4,154,323	5/1979	Sneider	D3/52
4,194,601	3/1980	Yellin	D3/43
4,197,891	4/1980	Comollo	D3/43
4,566,130	1/1986	Coates	383/4

Primary Examiner—George P. Word
Attorney, Agent, or Firm—Cislo, O'Reilly & Thomas

[57] CLAIM

The ornamental design for a tote bag, as shown and described.

DESCRIPTION

FIG. 1 is a perspective view of a tote bag showing our new design;
FIG. 2 is a front elevational view thereof;
FIG. 3 is a right side elevational view thereof;
FIG. 4 is a rear elevational view thereof;
FIG. 5 is a left side elevational view thereof;
FIG. 6 is a top plan view thereof;
FIG. 7 is a bottom plan view thereof; and
FIG. 8 is a perspective view of the tote bag in the open position.

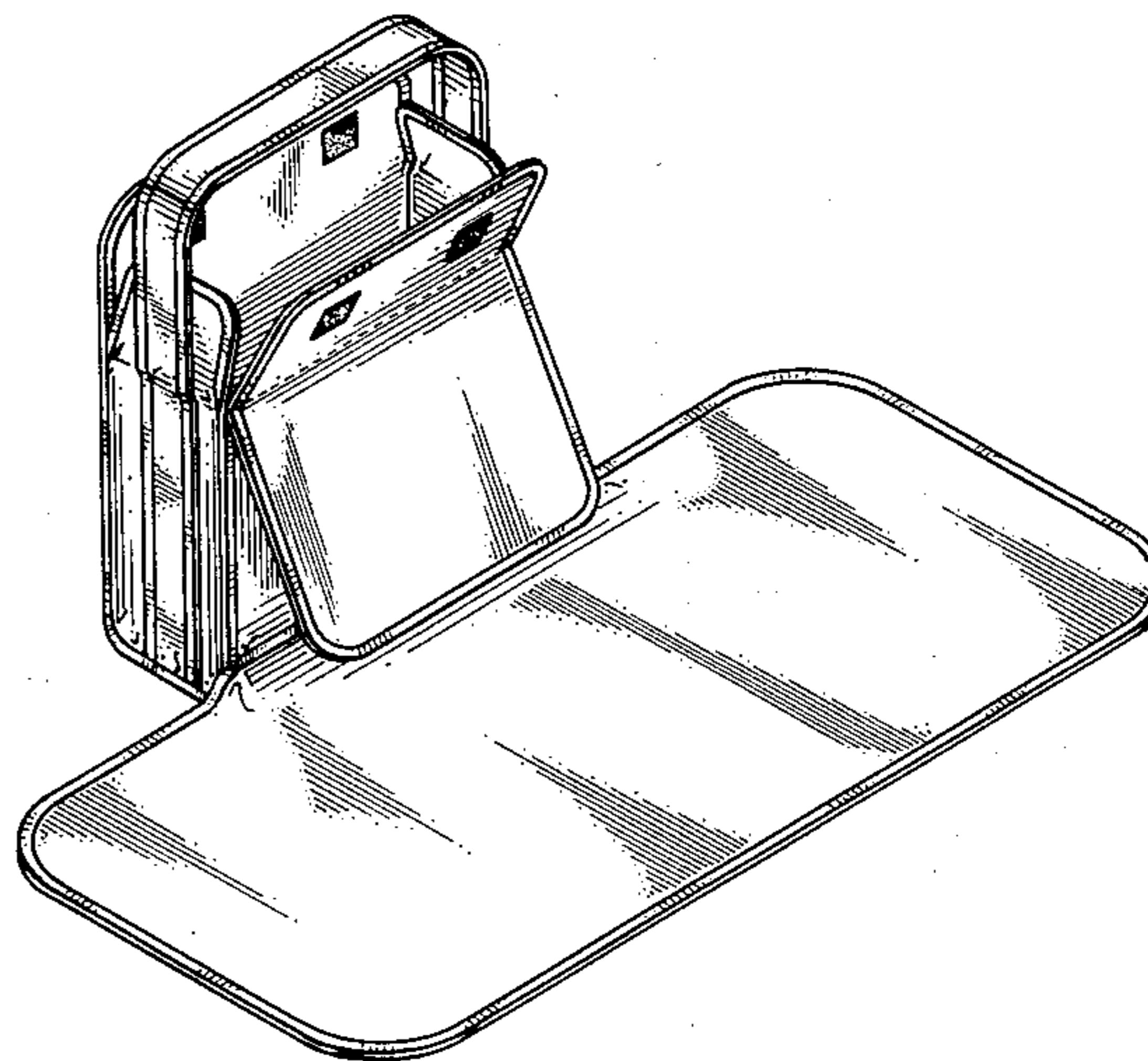
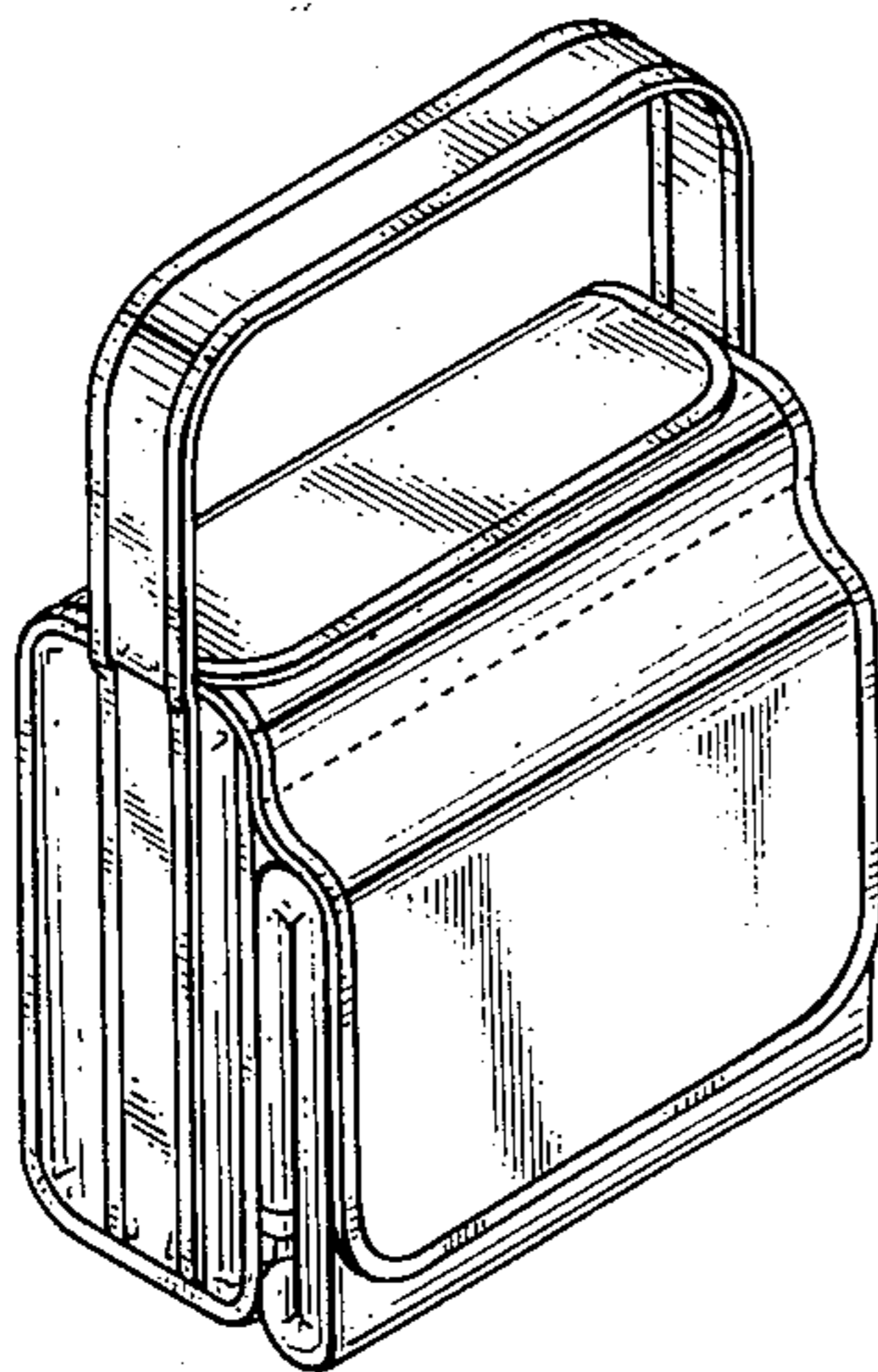

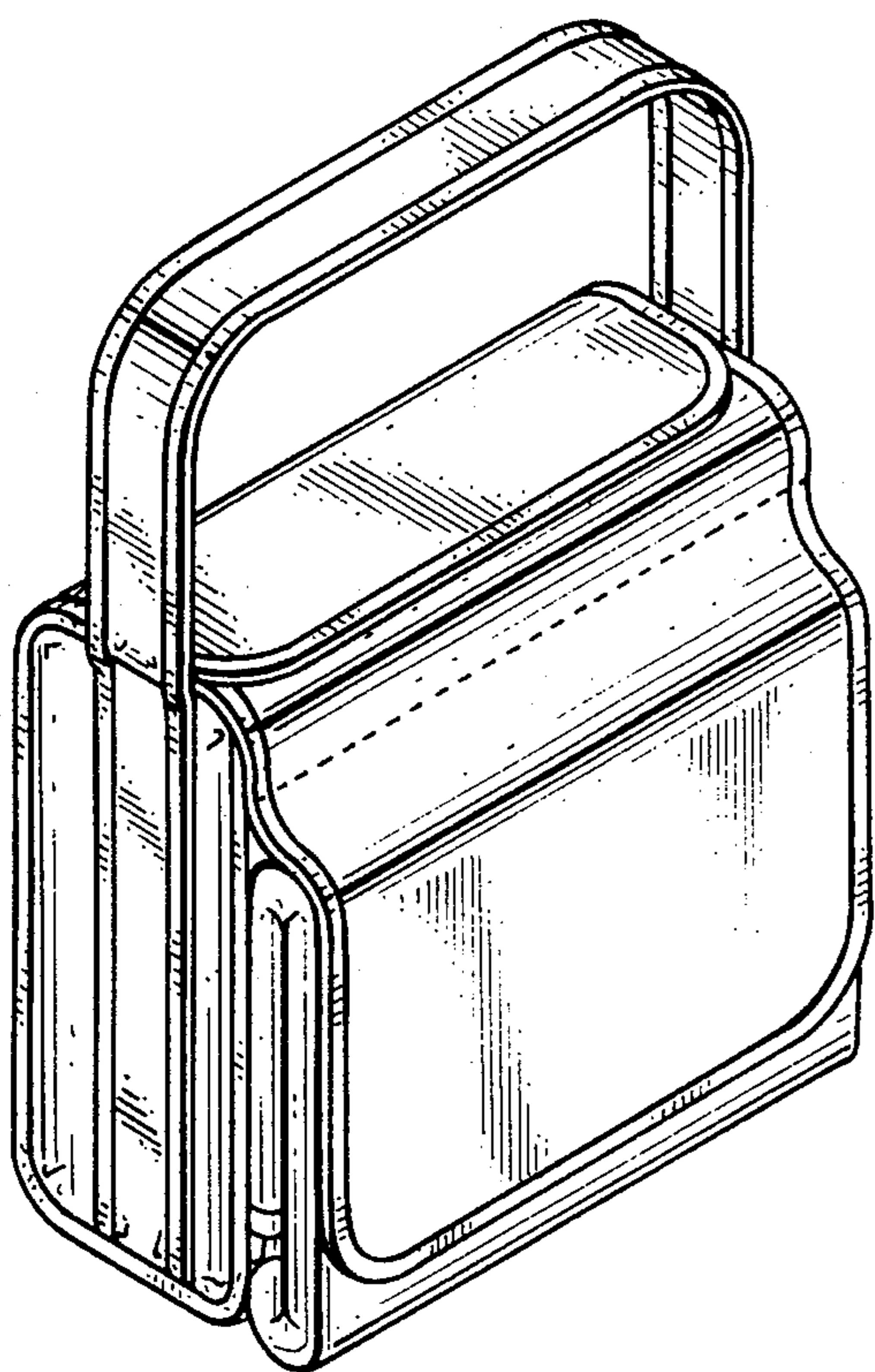

Fig. 1.

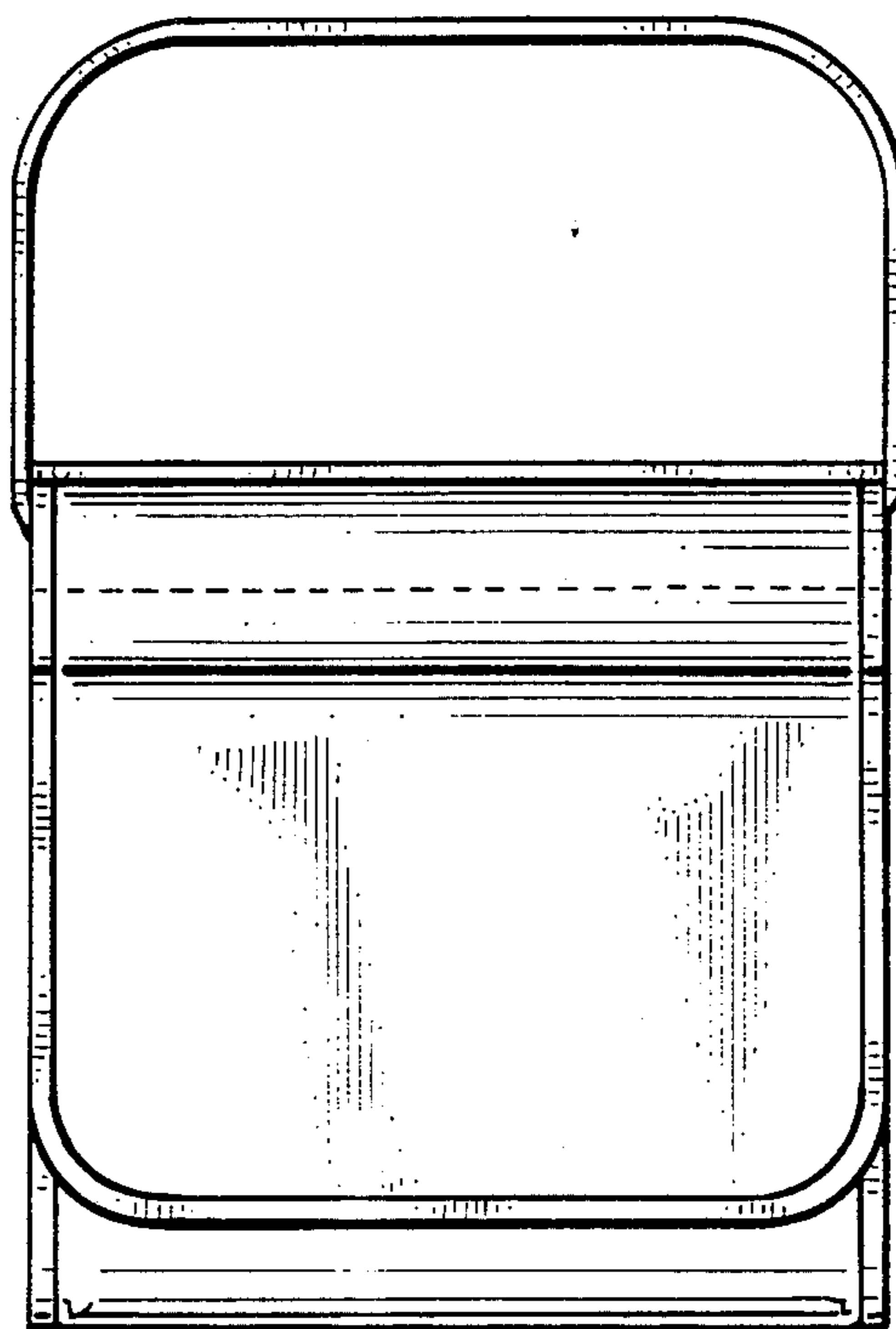

Fig. 2.

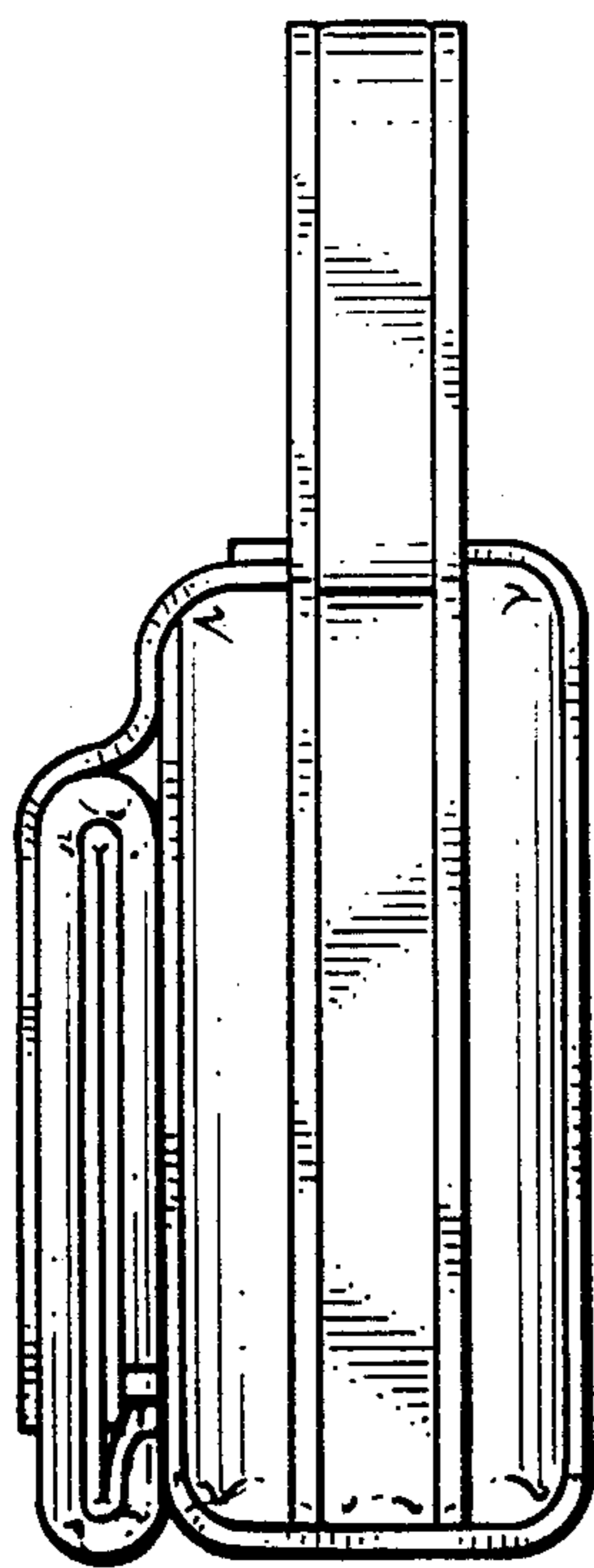

Fig. 3.

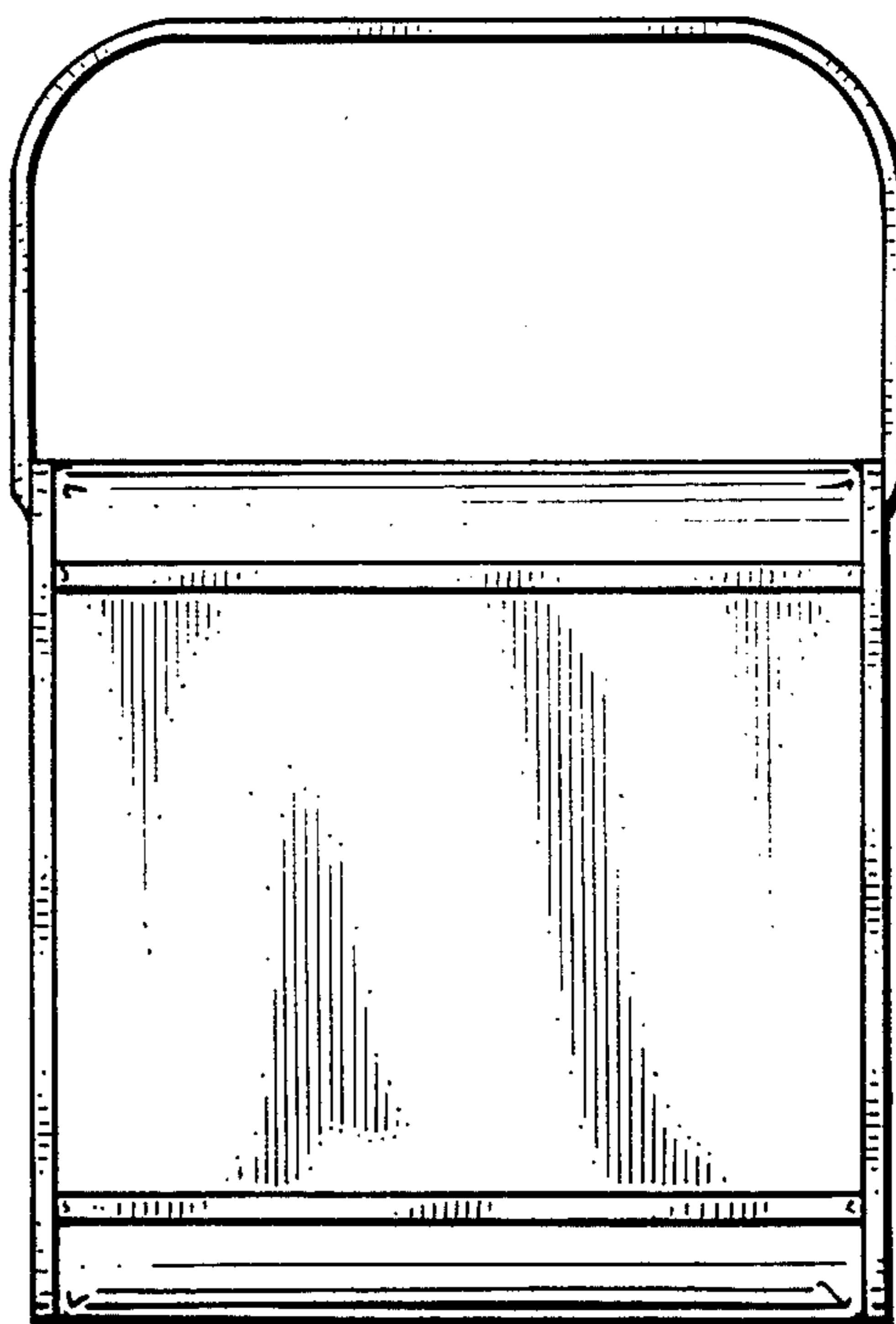

Fig. 4.

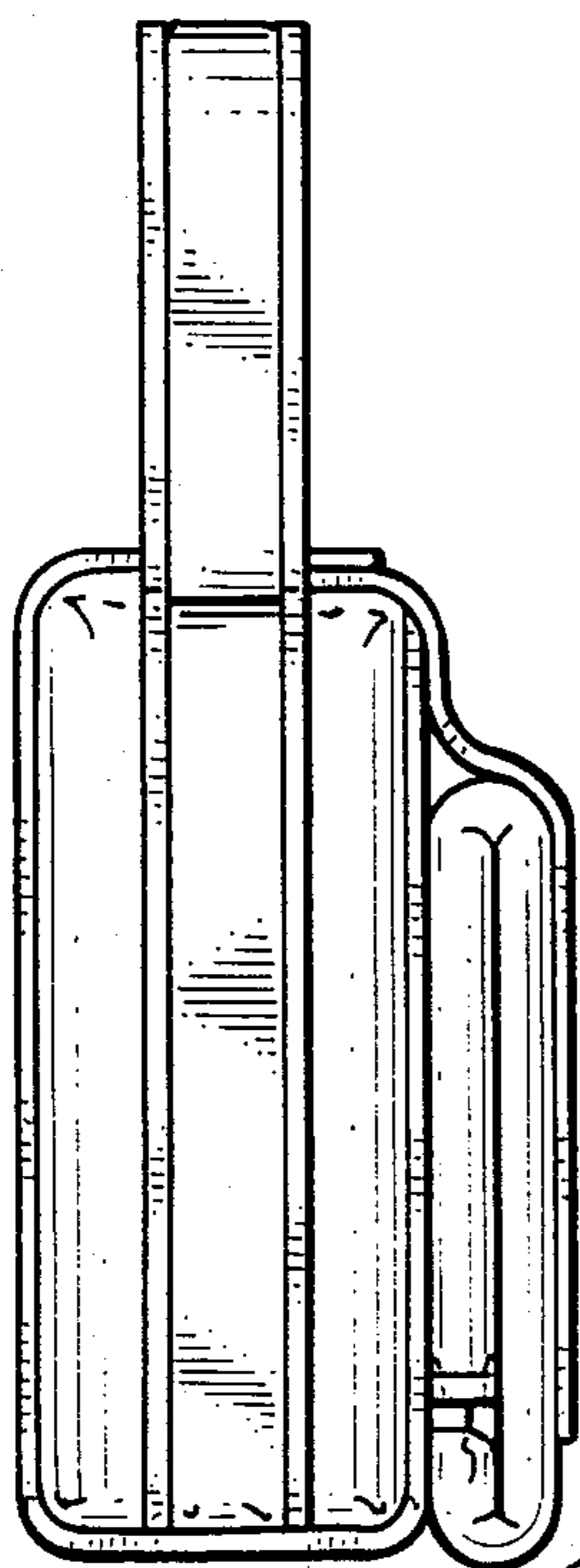

Fig. 5.

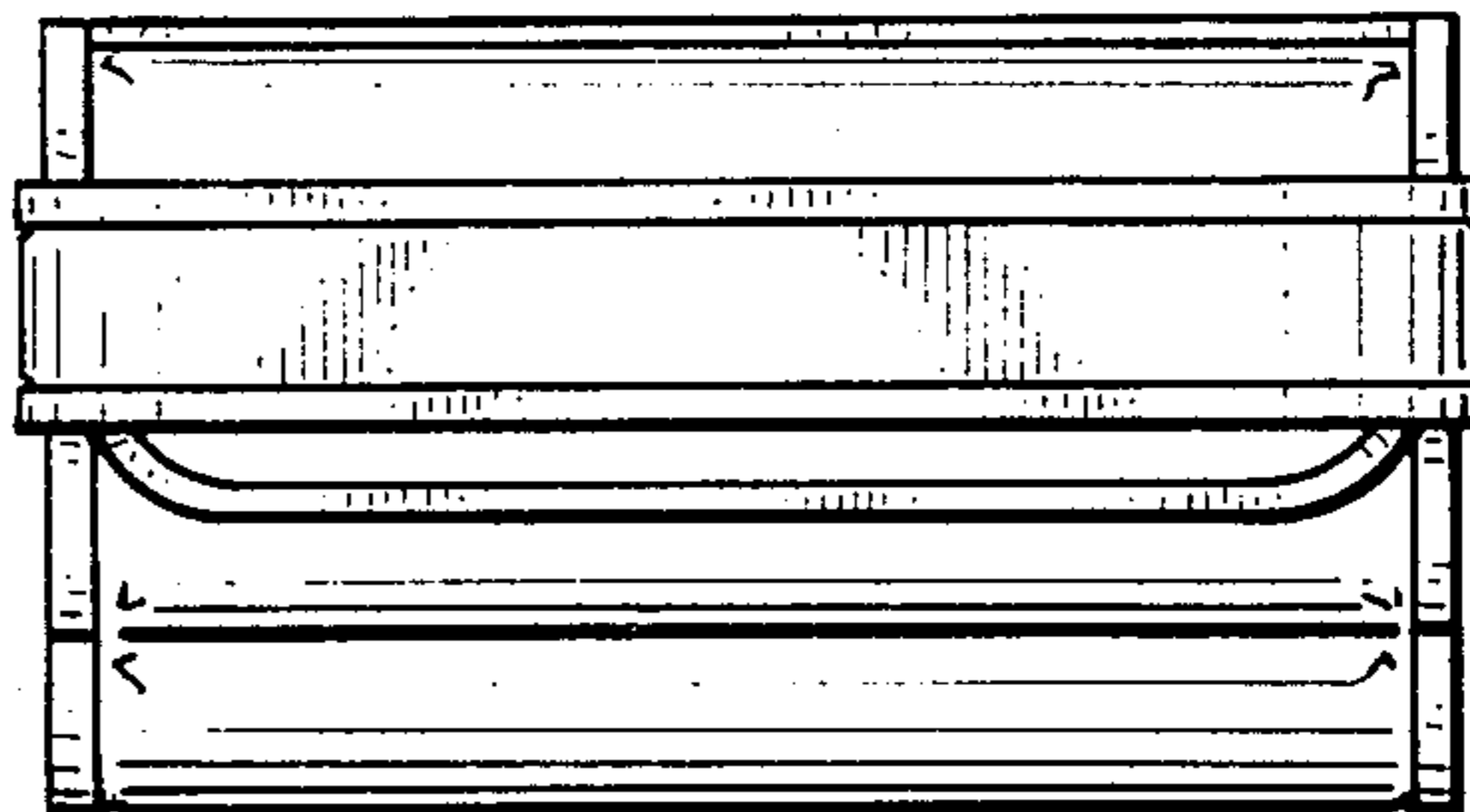

Fig. 6.

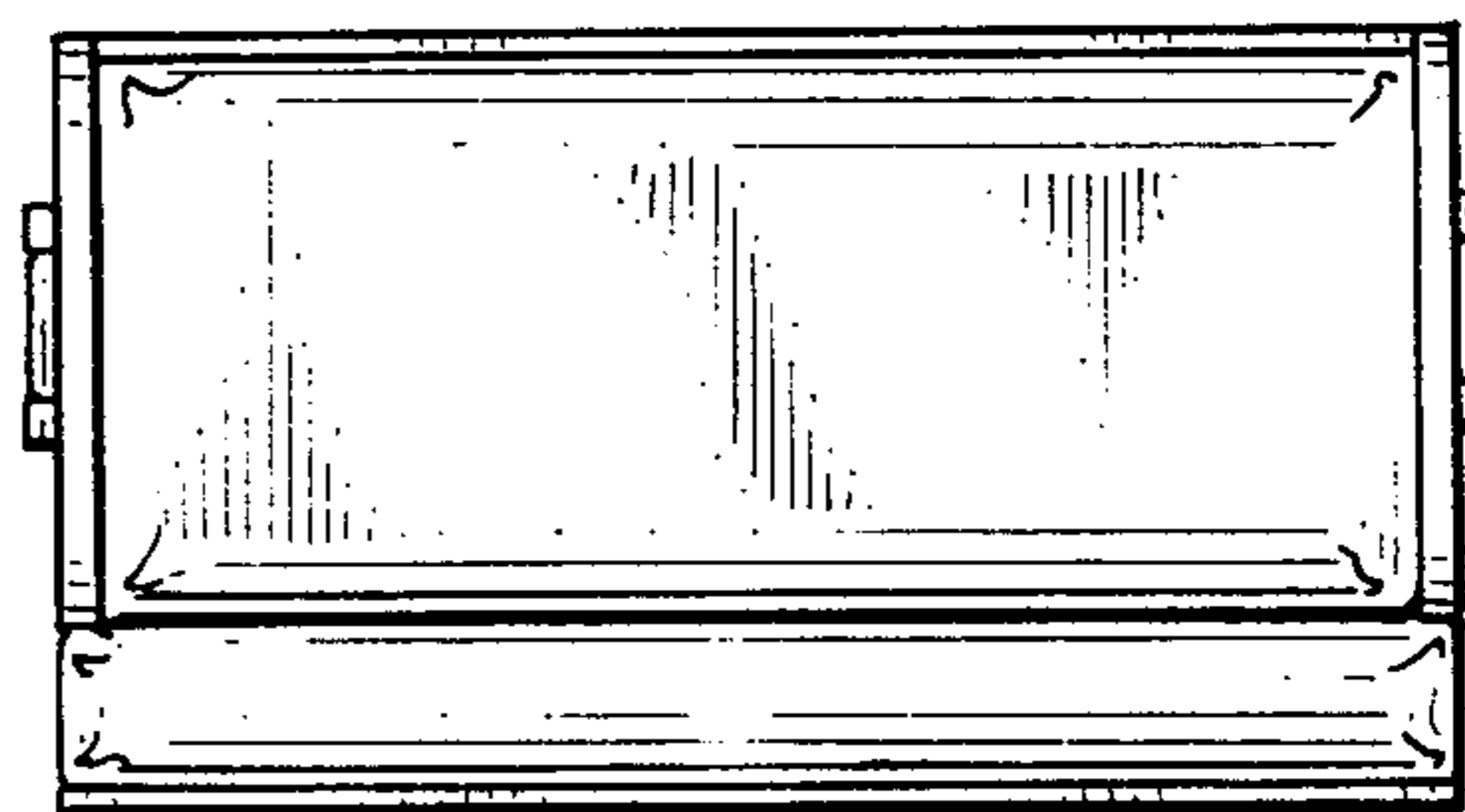

Fig. 7.

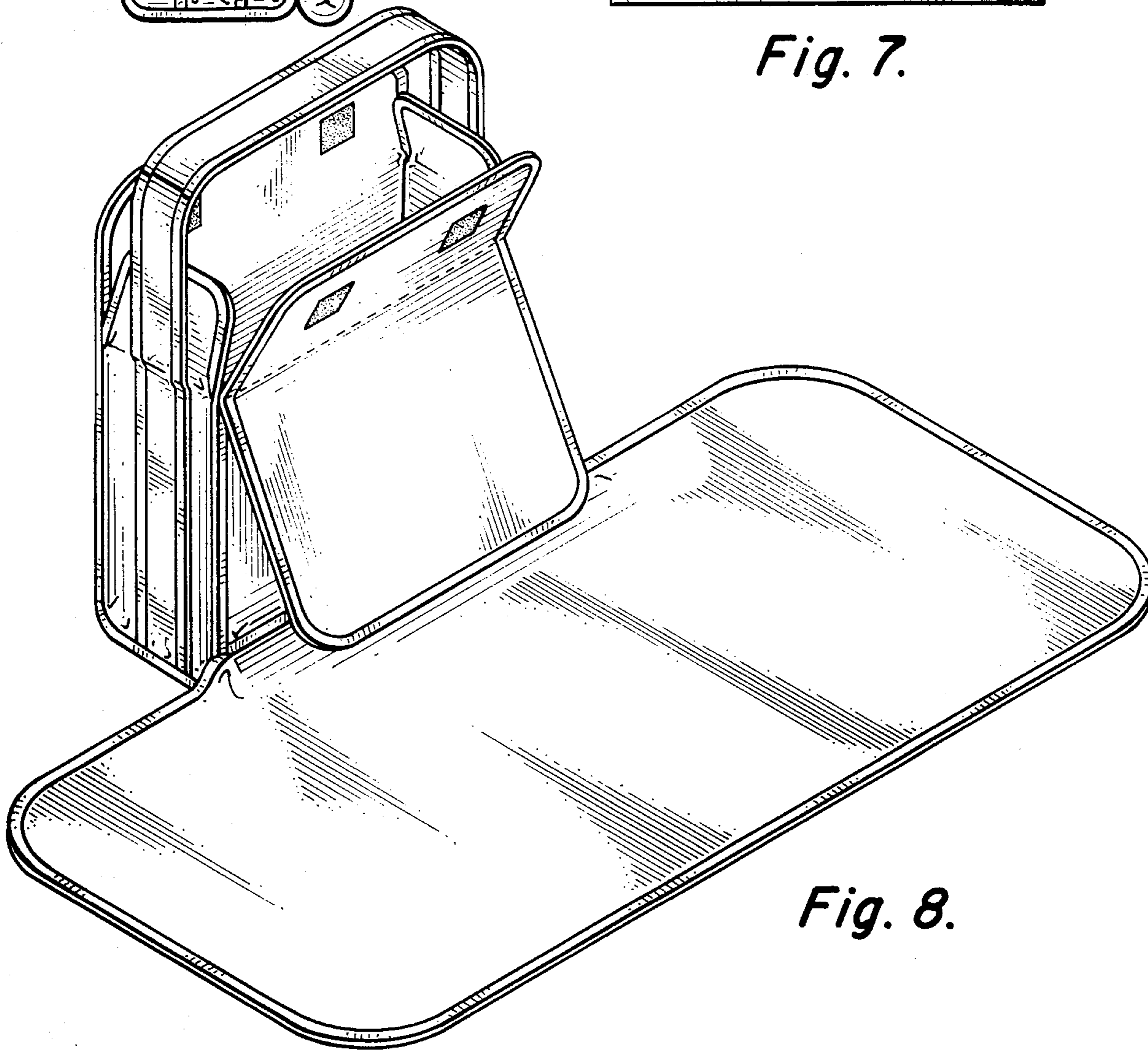

Fig. 8.