

[54] BALANCE PANEL FOR AN AUTOMOBILE

[75] Inventors: Mitsuo Kato; Hideto Kikuchi, both of Hachioji, Japan

[73] Assignee: Toyota Jidosha Kabushiki Kaisha, Toyota, Japan

[**] Term: 14 Years

[21] Appl. No.: 638,651

[22] Filed: Aug. 7, 1984

[52] U.S. Cl. D12/181

[58] Field of Search D12/181; 296/1.5

[56] References Cited

U.S. PATENT DOCUMENTS

D. 274,140 6/1984 Koch D12/181

OTHER PUBLICATIONS

Hot Rod, 4/83, p. 7, Front Spoiler on Nissan Pickup Truck, bottom of page.

Road & Track, 2/83, p. 51, Front Spoiler on Toyota Cressida, top of page.

Primary Examiner—James M. Gandy
Attorney, Agent, or Firm—Cushman, Darby & Cushman

[57] CLAIM

The ornamental design for a balance panel for an automobile, as shown and described.

DESCRIPTION

FIG. 1 is a perspective view of a balance panel for an automobile showing our new design;
FIG. 2 is a front elevational view thereof;
FIG. 3 is a rear elevational view thereof;
FIG. 4 is a right side elevational view thereof;
FIG. 5 is a top plan view thereof;
FIG. 6 is a bottom plan view thereof; and
FIG. 7 is a perspective view thereof on a reduced scale, it being understood that the broken lines are for illustrative purposes only and form no part of the design.

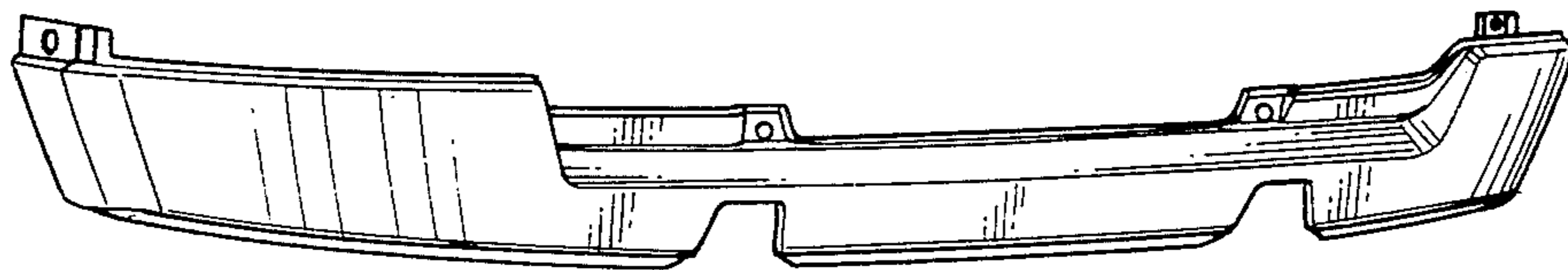

Fig. 1

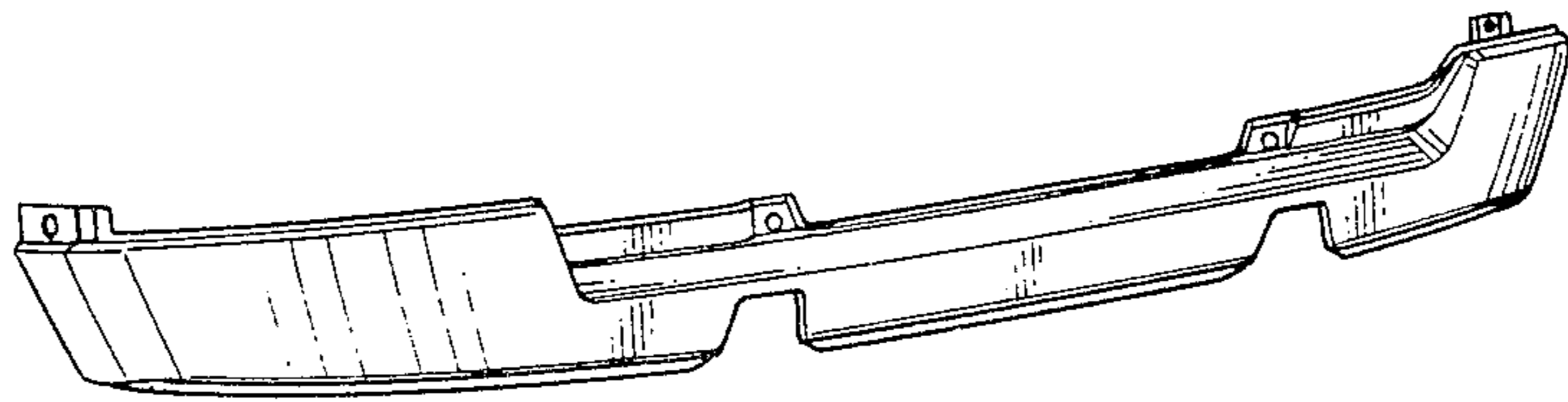

Fig. 2

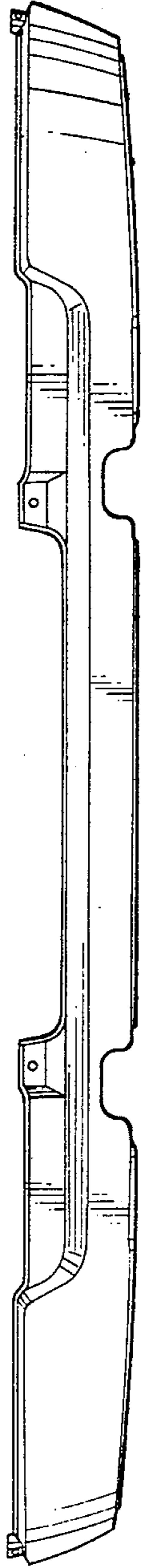

Fig. 3



Fig. 4

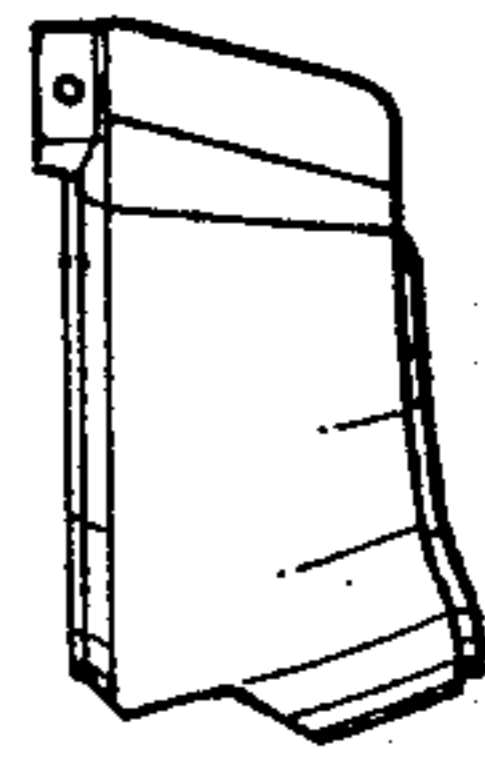

Fig. 5

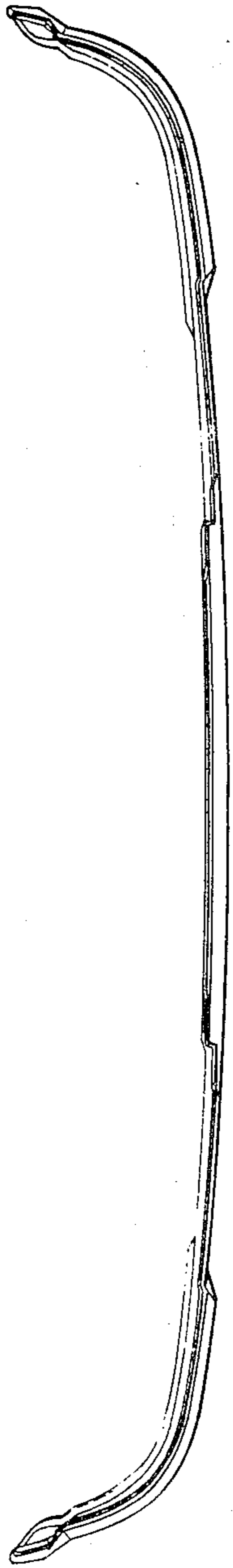

Fig. 6

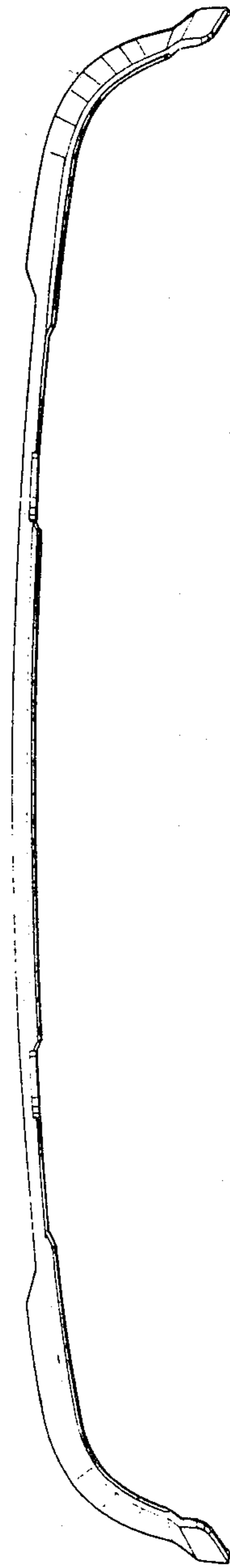

Fig.7

